

# **bizhub 423/363/283/223**

---

## **User's Guide [Enlarge Display Operations]**





# Table of contents

## 1 Introduction

<b>1.1</b>	<b>Welcome .....</b>	<b>1-2</b>
1.1.1	User's guides .....	1-2
1.1.2	User's Guide .....	1-3
<b>1.2</b>	<b>Conventions used in this manual .....</b>	<b>1-4</b>
1.2.1	Symbols used in this manual .....	1-4
	To use this machine safely.....	1-4
	Procedural instruction.....	1-4
	Key symbols.....	1-5
1.2.2	Original and paper indications .....	1-5
	Original and paper sizes .....	1-5
	Original and paper indications .....	1-5

## 2 Before use

<b>2.1</b>	<b>Control Panel and functions .....</b>	<b>2-2</b>
	Adjusting the angle of the Control Panel .....	2-4
	Touch Panel operation.....	2-5
2.1.1	Start, Stop, Reset.....	2-5
	Start .....	2-5
	Stop.....	2-5
	Reset .....	2-5
2.1.2	Copy and Fax/Scan .....	2-5
	Copy.....	2-5
	Fax/Scan .....	2-6
2.1.3	Utility/Counter .....	2-6
	[Default Enlarge Display Settings].....	2-7
2.1.4	Mode Memory.....	2-7
2.1.5	Accessibility .....	2-8
2.1.6	Enlarge Display .....	2-10
	Icon .....	2-10
2.1.7	Access .....	2-10
	How to log in when the authentication settings are configured .....	2-10
2.1.8	C (Clear) .....	2-11
2.1.9	Proof Copy.....	2-12
<b>2.2</b>	<b>Loading originals.....</b>	<b>2-13</b>
	Loading the original into the ADF .....	2-13
	Placing the original on the Original Glass .....	2-13

## 3 How to use Copy mode

<b>3.1</b>	<b>General copy operation .....</b>	<b>3-2</b>
<b>3.2</b>	<b>[Basic] .....</b>	<b>3-4</b>
3.2.1	[Density] .....	3-4
3.2.2	[Paper].....	3-6
3.2.3	[Zoom].....	3-7
3.2.4	[Duplex/Combine] .....	3-8
3.2.5	[Finishing] .....	3-10
3.2.6	[Auto Rotate OFF] .....	3-12
<b>3.3</b>	<b>[Original Setting] .....</b>	<b>3-13</b>
3.3.1	[Binding Position]/[Original Binding Pos.](Binding Position) .....	3-13
3.3.2	[Original Type] .....	3-14
3.3.3	[Original Direction].....	3-15



3.3.4	[Mixed Original] .....	3-16
3.3.5	[Z-Folded Original] .....	3-17

## 4 How to use Fax/Scan mode

<b>4.1</b>	<b>General fax/scan operation</b> .....	<b>4-2</b>
<b>4.2</b>	<b>Configuring destinations</b> .....	<b>4-4</b>
	Transmission options .....	4-4
	Configuring the destinations .....	4-4
4.2.1	[Address Book].....	4-5
4.2.2	[Job History] .....	4-6
4.2.3	[Address Search].....	4-7
4.2.4	[Fax Number].....	4-8
<b>4.3</b>	<b>[Scan Settings]</b> .....	<b>4-9</b>
4.3.1	[Simplex/Duplex] .....	4-9
4.3.2	[Original Type] .....	4-10
4.3.3	[Resolution] .....	4-11
4.3.4	[Density] .....	4-12
4.3.5	[File Type] .....	4-12
4.3.6	[Color].....	4-13
4.3.7	[Scan Size] .....	4-13
4.3.8	[Background Removal].....	4-14
4.3.9	[Original Settings] .....	4-15
	[Original Direction].....	4-15
	[Binding Position] .....	4-16
<b>4.4</b>	<b>[Destination Settings]</b> .....	<b>4-17</b>

## 5 Index

<b>5.1</b>	<b>Index by item</b> .....	<b>5-2</b>
<b>5.2</b>	<b>Index by button</b> .....	<b>5-3</b>



# Introduction

# 1 Introduction

## 1.1 Welcome

Thank you for purchasing this machine.

This User's Guide describes the functions, operating instructions, precautions for correct operation, and simple troubleshooting guidelines of this machine. In order to obtain maximum performance from this product and use it effectively, please read this User's Guide as necessary.

### 1.1.1 User's guides

Printed manual	Overview
[Quick Guide Copy/Print/Fax/Scan/Box Operations]	This manual describes operating procedures and the functions that are most frequently used in order to enable you to begin using this machine immediately. This manual also contains notes and precautions that should be followed to ensure safe usage of this machine. Please be sure to read this manual before using this machine.
User's guide CD manuals	Overview
[User's Guide Copy Operations]	This manual describes details on copy mode operations and the settings of this machine. <ul style="list-style-type: none"> <li>• Specifications of originals and copy paper</li> <li>• Copy function</li> <li>• Maintaining this machine</li> <li>• Troubleshooting</li> </ul>
[User's Guide Enlarge Display Operations]	This manual describes details on operating procedures of the enlarge display mode. <ul style="list-style-type: none"> <li>• Copy function</li> <li>• Scanning function</li> <li>• G3 fax function</li> <li>• Network fax function</li> </ul>
[User's Guide Print Operations]	This manual describes details on printer functions. <ul style="list-style-type: none"> <li>• Printer function</li> <li>• Setting the printer driver</li> </ul>
[User's Guide Box Operations]	This manual describes details on user box functions. <ul style="list-style-type: none"> <li>• Saving data in user boxes</li> <li>• Retrieving data from user boxes</li> <li>• Transferring and printing data from user boxes</li> </ul>
[User's Guide Network Scan/Fax/Network Fax Operations]	This manual describes details on transmitting scanned data. <ul style="list-style-type: none"> <li>• E-mail TX, FTP TX, SMB TX, Save in User Box, WebDAV TX, Web Services</li> <li>• G3 fax</li> <li>• IP Address Fax, Internet Fax</li> </ul>
[User's Guide Fax Driver Operations]	This manual describes details on the fax driver function that transmits faxes directly from a computer. <ul style="list-style-type: none"> <li>• PC-FAX</li> </ul>
[User's Guide Network Administrator]	This manual describes details on setting methods for each function using the network connection. <ul style="list-style-type: none"> <li>• Network settings</li> <li>• Settings using <b>PageScope Web Connection</b></li> </ul>

User's guide CD manuals	Overview
[User's Guide Advanced Function Operations]	This manual describes details on functions that become available by registering the optional license kit and by connecting to an application. <ul style="list-style-type: none"><li>• Web browser function</li><li>• Image panel</li><li>• PDF Processing Function</li><li>• Searchable PDF</li><li>• My panel and My address functions</li></ul>
[Trademarks/Copyrights]	This manual describes details on trademarks and copyrights. <ul style="list-style-type: none"><li>• Trademarks and copyrights</li></ul>

## 1.1.2 User's Guide

This User's Guide is intended for users ranging from those using this machine for the first time to administrators.

It describes basic operations, functions that enable more convenient operations, maintenance procedures, simple troubleshooting operations, and various setting methods of this machine.

Note that basic technical knowledge about the product is required to enable users to perform maintenance work or troubleshooting operations. Limit your maintenance and troubleshooting operations to the areas explained in this manual.

Should you experience any problems, please contact our service representative.

## 1.2 Conventions used in this manual

### 1.2.1 Symbols used in this manual

Symbols are used in this manual to express various types of information.

The following describes each symbol related to correct and safe usage of this machine.

#### To use this machine safely

##### ⚠ WARNING

- This symbol indicates that a failure to heed the instructions may lead to death or serious injury.

##### ⚠ CAUTION

- This symbol indicates that negligence of the instructions may lead to mishandling that may cause injury or property damage.

##### **NOTICE**

*This symbol indicates a risk that may result in damage to this machine or documents. Follow the instructions to avoid property damage.*

#### Procedural instruction

- ✓ This check mark indicates an option that is required in order to use conditions or functions that are prerequisite for a procedure.

1 This format number "1" represents the first step.

2 This format number represents the order of serial steps.

- This symbol indicates a supplementary explanation of a procedural instruction.

The operation procedures are described using illustrations.

- This symbol indicates transition of the **Control Panel** to access a desired menu item.

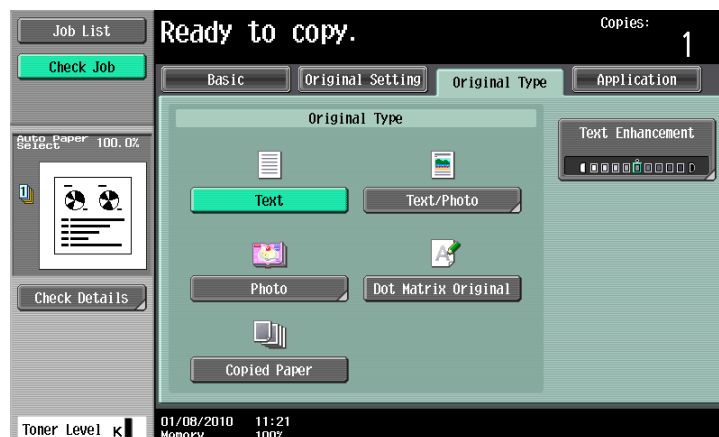

This symbol indicates a desired page.



### Reference

*This symbol indicates a reference.*

*View the reference as required.*

### Key symbols

[ ]

Key names on the **Touch Panel** or computer screen, or a name of user's guide are indicated by these brackets.

**Bold text**

Key names, part names, product names and option names on the **Control Panel** are indicated in bold text.

## 1.2.2 Original and paper indications

### Original and paper sizes

The following explains the indication for originals and paper described in this manual.

When indicating the original or paper size, the Y side represents the width and the X side the length.

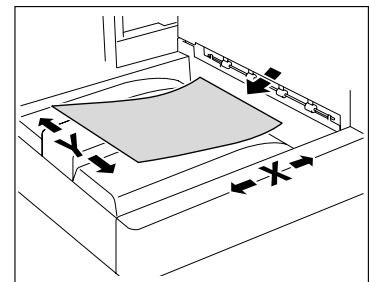

### Original and paper indications

☐ indicates the paper size with the length (X) being longer than the width (Y).

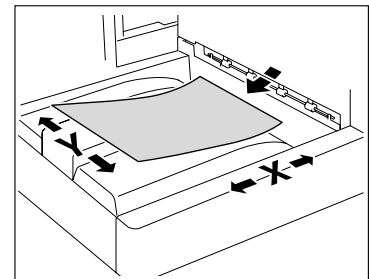

☐ indicates the paper size with the length (X) being shorter than the width (Y).

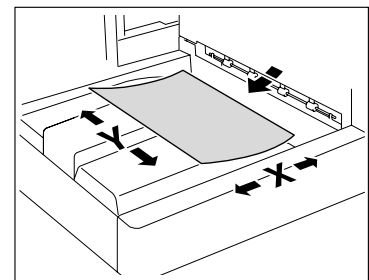

---

**2** Before use

## 2 Before use

This section describes information you should be aware of before using this machine.

### 2.1 Control Panel and functions

Configuration settings of this machine are made with either the **Touch Panel** or the hard keys in the **Control Panel**. This section describes the configuration and operations in the enlarge display mode that are made using the hard keys in the **Control Panel**. For details on configuration using the **Touch Panel**, refer to "3 How to use Copy mode" and "4 How to use Fax/Scan mode".



#### Reference

For details on the name and function of each component in the **Control Panel**, refer to the [User's Guide Copy Operations] and the [User's Guide Network Scan/Fax/Network Fax Operations].

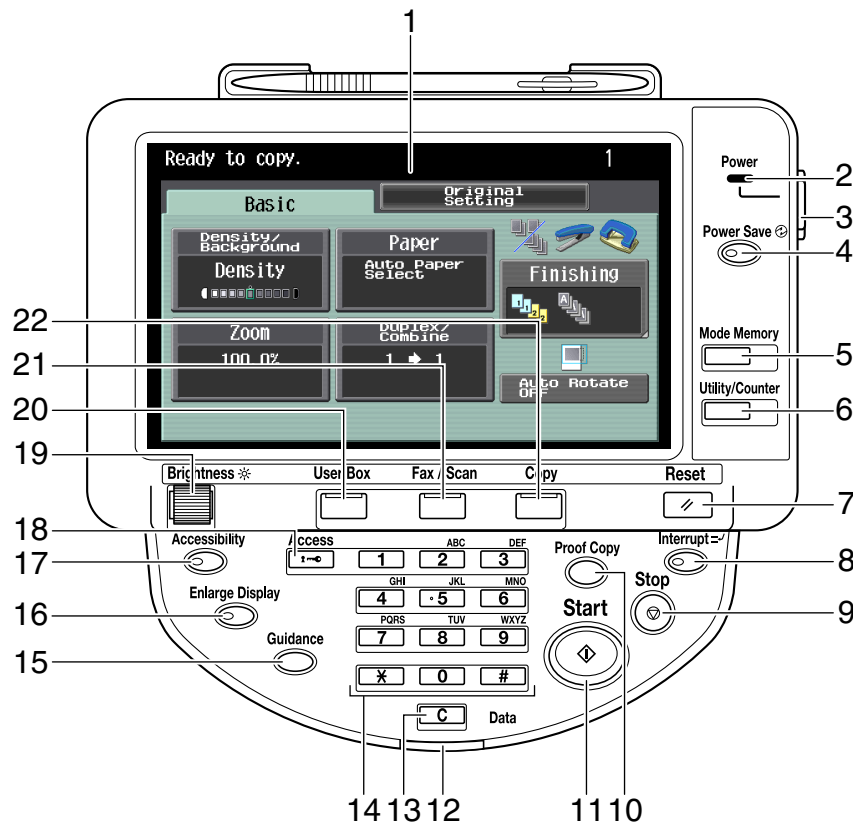

Overview		Reference
1	<b>Touch Panel</b>	Various screens and messages are displayed. You can configure various settings by directly pressing the <b>Touch Panel</b> .
2	<b>Power Indicator</b>	Lights up in blue when the machine is turned on with the <b>Main Power Switch</b> .
3	<b>Sub Power Switch</b>	Press this switch to turn on/off machine operations. When turned off, the machine enters an energy conservation state.

Overview			Reference
4	<b>Power Save</b>	Press this key to enter Power Save mode. While the machine is in Power Save mode, the indicator on the <b>Power Save</b> key lights up in green and the <b>Touch Panel</b> goes off. To exit from Power Save mode, press the <b>Power Save</b> key again.	-
5	<b>Mode Memory</b>	Press this key to recall registered fax/scan settings.	p. 2-7
6	<b>Utility/Counter</b>	Press this key to display the Utility screen and the Meter Count screen.	p. 2-6
7	<b>Reset</b>	Press this key to reset all settings (except programmed settings) entered using the <b>Control Panel</b> and <b>Touch Panel</b> .	p. 2-5
8	<b>Interrupt</b>	This key is not used in the enlarge display mode.	-
9	<b>Stop</b>	Pressing this key while copying, scanning or printing temporarily stops the operation.	p. 2-5
10	<b>Proof Copy</b>	Press this key to print a single proof copy to be checked before printing a large number of copies.	p. 2-12
11	<b>Start</b>	Press to start the copy, scan or fax operation.	p. 2-5
12	<b>Data Indicator</b>	Flashes in blue while a print job is being received. Lights up in blue when a print job is queued to be printed or while it is being printed. The indicator lights up in blue when there is saved fax data or unprinted fax data.	-
13	<b>C (clear)</b>	Press this key to clear a value (such as the number of copies and a zoom ratio) entered using the <b>Keypad</b> .	p. 2-11
14	<b>Keypad</b>	Use the keypad to enter the number of copies, zoom ratio, and a fax number.	-
15	<b>Guidance</b>	This key is not used in the enlarge display mode.	-
16	<b>Enlarge Display</b>	Press this key to switch between the enlarged display screen and the standard size screen. If you use <b>PageScope Authentication Manager</b> for authentication, the Enlarge Display screen is not available.	p. 2-10
17	<b>Accessibility</b>	Press this key to display the screen for configuring settings for user accessibility function.	p. 2-8
18	<b>Access</b>	If user authentication or account track is enabled, press this key after entering the user name and password (for user authentication) or the account name and password (for account track) in order to use this machine.	p. 2-10
19	<b>Brightness dial</b>	Allows you to adjust the brightness of the <b>Touch Panel</b> .	-
20	<b>User Box</b>	This key is not used in the enlarge display mode.	-
21	<b>Fax/Scan</b>	Enters Fax/Scan mode. While the machine is in Fax/Scan mode, the indicator on the <b>Fax/Scan</b> key lights up in green.	p. 2-6
22	<b>Copy</b>	Press this key to enter Copy mode. (As a default, the machine is in Copy mode.) While the machine is in Copy mode, the indicator on the <b>Copy</b> key lights up in green.	p. 2-5

## Adjusting the angle of the Control Panel

You can adjust the angle of the **Control Panel** of this machine to four different levels. You can also tilt the control pane to the left.

Set it to your desired position.

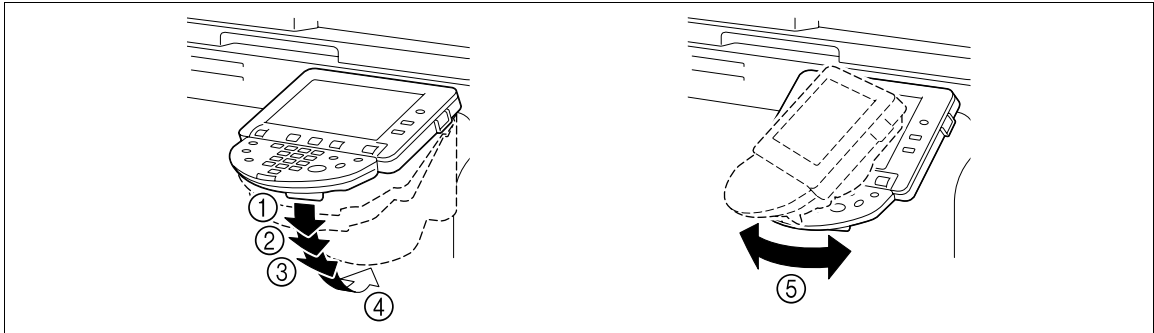

### NOTICE

Do not adjust the **Touch Panel** in the horizontal direction while directly holding the **Control Panel**.

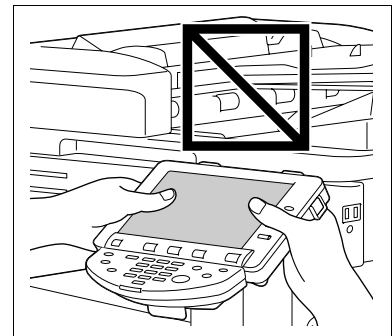

- Pull the **Control Panel Release Lever** toward you, and then slowly move the **Control Panel** up or down.

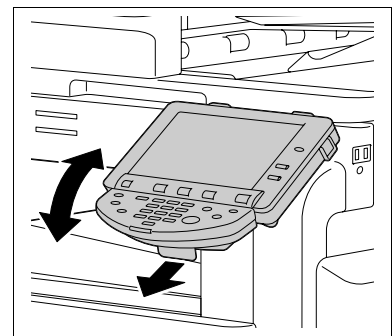

- To tilt the **Control Panel**, hold the bottom of the **Control Panel**, and then adjust the panel in the horizontal direction.

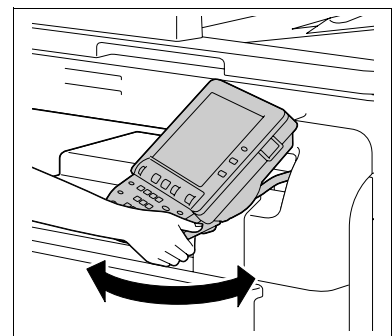

## Touch Panel operation

Lightly press the button displayed in the **Touch Panel** with your finger or a **Stylus Pen** to select the displayed function.

### NOTICE

*Do not apply excessive pressure on the **Touch Panel**. Such impact may leave a flaw on the panel, inviting damage to the **Touch Panel**. Never forcibly push down on the **Touch Panel**, and never use a hard or pointed object to make a selection in it.*

### 2.1.1 Start, Stop, Reset

#### Start

→ Press the **Start** key.

A copy, scan or fax operation starts. Also, pressing this key restarts a stopped job.

- When this machine is ready to begin a process, the indicator on the **Start** key lights up in blue.
- If the indicator on the **Start** key lights up in orange, the operation cannot begin. Check the screen for any warnings or other messages.

#### Stop

→ To temporarily stop the copy, scan, or print operation, press the **Stop** key.

The operation temporarily stops.

- To resume a temporarily stopped job, press the **Start** key.
- To delete a temporarily stopped job, select a job in the Stopped Jobs screen, and then press [Delete].

#### Reset

→ Press the **Reset** key.

The screen returns to the default settings, and the basic settings screen appears.

- The settings entered in the **Control Panel** and **Touch Panel** are canceled. The registered settings are not erased.

### 2.1.2 Copy and Fax/Scan

Select a function according to your desired operation. The indicator on the selected function key lights up in green.

#### Copy

→ Press the **Copy** key to enter Copy mode.

The basic settings screen for Copy mode appears.

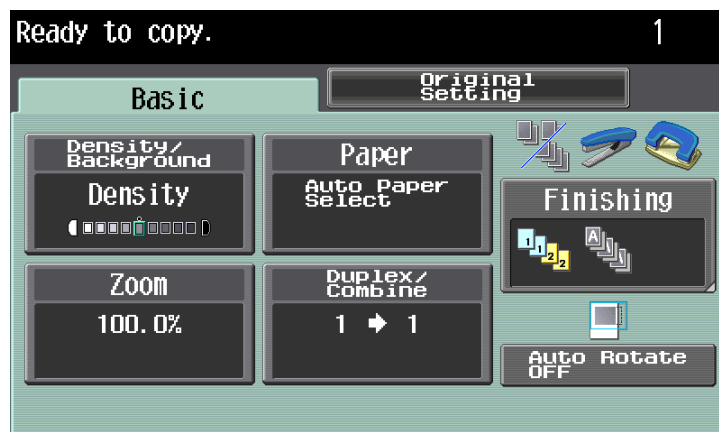

## Fax/Scan

→ Press the **Fax/Scan** key to enter Fax/scan mode.

The basic settings screen for Fax/Scan mode appears.



### 2.1.3 Utility/Counter

Press the **Utility/Counter** key to display the Utility screen, which allows you to configure or check the usage status of this machine.

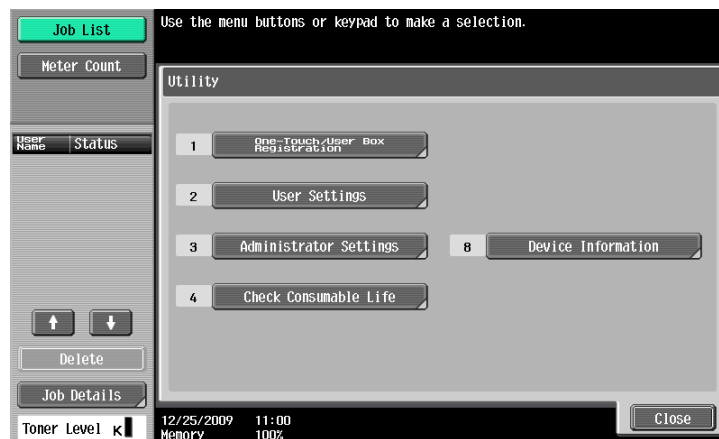

You can configure the default enlarge display settings in [User Settings].

## [Default Enlarge Display Settings]

The default settings for Copy mode or Fax/Scan mode can be configured.

- ✓ Display the enlarged display screen of the mode to be configured, and configure the settings in advance.
- ➔ Display the enlarged display screen of the mode to be configured, and then press the **Utility/Counter** ➤ [User Settings] ➤ [Copier Settings] or [Scan/Fax Settings] ➤ [Default Enlarge Display Settings] to apply the settings.

<In case of [Copier Settings]>

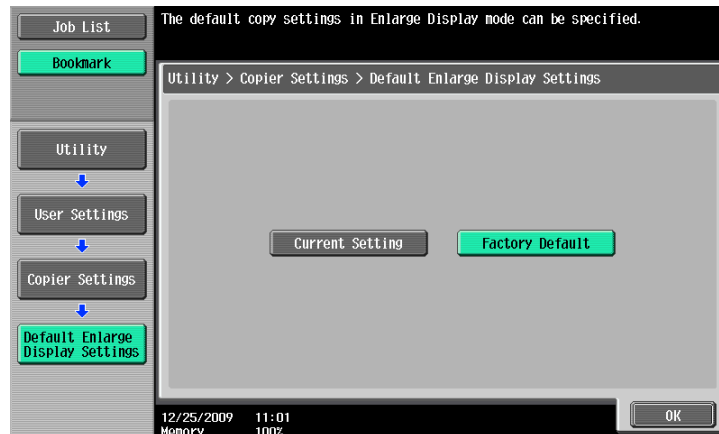

### Settings

[Default Enlarge Display Settings]	[Current Setting]	The settings configured before pressing the <b>Utility/Counter</b> key are registered as the default settings for Copy or Fax/Scan mode.
	[Factory Default]	The factory default settings are registered as the default settings for Copy or Fax/Scan mode.



### Reference

You can also configure the default enlarge display settings in the Accessibility screen. For details, refer to page 2-8.

## 2.1.4 Mode Memory

Display the Fax/Scan screen, and then press the **Mode Memory** key to recall a fax/scan program in which destination and scan settings are collectively registered. This is convenient for frequently sending data under the same conditions.

- ✓ You must register programmed settings using the standard screen in advance.
- ✓ For details on registering programs, refer to [User's Guide Network Scan/Fax/Network Fax Operations].
- ➔ Display the Fax/Scan screen, and then press the **Mode Memory** key.



**Settings**

[Recall Scan/Fax Program]	Select the desired program. Only one program can be selected.
[Page List]	Select the page to be displayed.
[Previous Page]	Press either of the two buttons to move to the previous or next page.
[Next Page]	
[Main Screen]	Press this button to return to the basic settings screen with the changed settings applied.

**Reference**

An address can be added to the selected program. For details on adding an address, refer to page 4-4.

**2.1.5 Accessibility**

To configure the **Control Panel** settings or adjust the **Touch Panel**, press the **Accessibility** key.

→ Press the **Accessibility** key.

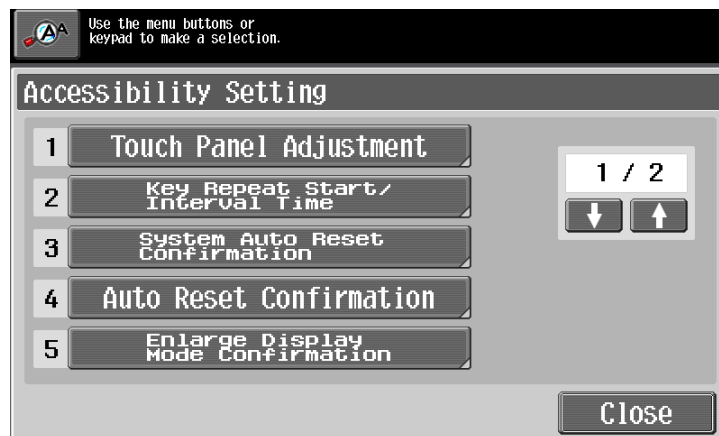

## Settings

[Touch Panel Adjustment]	<p>If no normal reaction is returned after pressing a key on the <b>Touch Panel</b>, the key display position on the <b>Touch Panel</b> may not be correctly aligned with the actual position of the touch sensor.</p> <p>Adjust the display position of the <b>Touch Panel</b>.</p> <ul style="list-style-type: none"> <li>• The touch sensors are not aligned in the touch panel if pressing [Touch Panel Adjustment] does not activate any action. Press the <b>1</b> key on the <b>Keypad</b>.</li> <li>• Press the four check point buttons [+] on the touch panel adjustment screen while listening on a buzzer sound each time. When the checking by pressing the check point buttons is completed successfully, the indicator on the <b>Start</b> key lights up in blue. Press the <b>Start</b> key.</li> <li>• The check point buttons [+] can be pressed in any order.</li> <li>• To perform adjustment again, press the <b>C</b> (Clear) key, and then press the four check point buttons [+] again.</li> <li>• To cancel the <b>Touch Panel</b> adjustment process, press the <b>Stop</b> or <b>Reset</b> key.</li> <li>• If the touch panel cannot be adjusted, contact your service representative.</li> </ul>
[Key Repeat Start/Interval Time]	<p>The time interval of continuous operation can be specified when a button in the <b>Touch Panel</b> is kept pressed in the enlarged display screen. [Time To Start] defines the time before a continuous operation starts when a button is kept pressed. [Interval] defines the time interval of a continuous operation when a button is kept pressed for a prolonged time.</p> <p>Press the corresponding button in the <b>Touch Panel</b>, or press the <b>2</b> key on the <b>Keypad</b>.</p>
[System Auto Reset Confirmation]	<p>Configure this setting to display the screen that allows you to select either to continue the operation without exiting the enlarge display mode or to exit the enlarge display mode and return to the basic settings screen when the system auto reset operation is invoked in the enlarged display.</p> <p>Press the corresponding button in the <b>Touch Panel</b>, or press the <b>3</b> key on the <b>Keypad</b>. To display a confirmation screen, select the length of time that the message is to be displayed.</p>
[Auto Reset Confirmation]	<p>Configure this setting to display the screen that allows you to select either to continue the operation without resetting the current settings or to reset the settings when the automatic reset operation is invoked in the enlarge display mode to reset the setting to the default.</p> <p>Press the corresponding button in the <b>Touch Panel</b>, or press the <b>4</b> key on the <b>Keypad</b>. To display a selection screen, select the length of time that the message is to be displayed.</p>
[Enlarge Display Mode Confirmation]	<p>When you press the <b>Enlarge Display</b> key to switch the screen to the enlarged display mode, those settings that cannot be configured in the enlarged display screen will be canceled. Configure this setting to display the screen that allows you to select either canceling those settings to enter the enlarge display mode or continuing the operation without entering the enlarged display mode.</p> <p>Press the corresponding button in the <b>Touch Panel</b>, or press the <b>5</b> key on the <b>Keypad</b>.</p>
[Message Display Time]	For details, refer to [User's Guide Copy Operations].
[Sound Setting]	For details, refer to [User's Guide Copy Operations].
[Default Enlarge Display Settings]	<p>Change the default settings of the enlarge display. Configure the default settings in the enlarged display screen, and then press the corresponding button in the <b>Touch Panel</b>, or press the <b>3</b> key on the <b>Keypad</b> in page [2/2]. Select a function, and select either [Factory Default] or [Current Setting].</p> <ul style="list-style-type: none"> <li>• [Default Enlarge Display Settings] can be configured by pressing the <b>Accessibility</b> key when the enlarged display screen is displayed.</li> <li>• Only the function displayed on the screen immediately before the <b>Accessibility</b> key is pressed can be selected.</li> <li>• You can also change the default settings in User Settings. For details, refer to page 2-7.</li> </ul>



## Reference

To return to the basic settings screen, press the **Accessibility**, [Close], or **Reset** key.

## 2.1.6 Enlarge Display

Pressing the **Enlarge Display** key switches the **Touch Panel** display to the enlarged display screen with large characters.

→ Press the **Enlarge Display** key.

The enlarged display screen appears.

→ When you switch the screen from the standard size to the enlarged display while configuring settings, those settings that cannot be configured in the enlarge display mode will be canceled.

→ To return to the standard size screen, press the **Enlarge Display** key again.

### Icon

The following icons are displayed in the enlarge display mode.

	Appears when a message related to a print error is received. Press the icon to display the message, and then correct the error.
	Press this icon to enlarge the message currently displayed.
	Appears when there is a message indicating that consumables must be replaced or the machine requires maintenance. Press this icon to display the message, and then perform the replacement or maintenance procedure.

## 2.1.7 Access

Access to this machine can be managed for each user or account. If user authentication is configured with Administrator Settings, it is possible to log in to and log out from the machine by pressing the **Access** key. For the necessary settings to log in to the machine, contact your administrator of this machine.

### How to log in when the authentication settings are configured

- ✓ The login screen that appears differs depending on the authentication settings configured on the machine.
- ✓ Alternately, the optional authentication unit can be used for logging in to the machine. For details, refer to [User's Guide Copy Operations].

→ Configure the necessary settings for logging in to the machine, and then press the **Access** key.

The basic settings screen appears.

<User Authentication>

Enter User Name and password, and then touch [Login] or press the [Access] key.

User Name [ ]

Password [ ]

Server Name server

Public User Access [ ] Login [ ]

&lt;Account Track&gt;

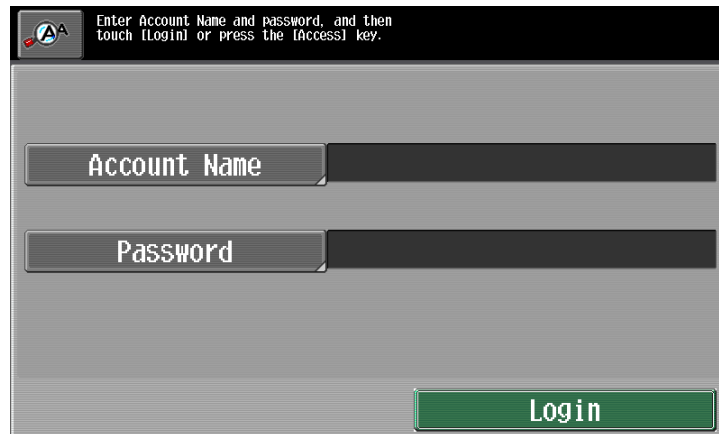

### Settings

User Authentication	Authentication is performed when a user logs in to this machine, allowing this machine to be used only by a specific registered user.	
	[User Name]	Enter the user name.
	[User Name List]	Press this button to display the list of user names and select a user name from the list.
	[Password]	Enter the user password.
	[Server Name]	The list of registered servers is displayed, and the desired server name can be selected from the list.
	[Public User Access]	Press this button to log in to this machine without authentication. Unregistered users can also use this machine.
	[Login]	To log in to this machine, you can press [Login] instead of the <b>Access</b> key.
Account Track	Authentication is performed when a user logs in to this machine, allowing this machine to be used only by users of a specific registered account.	
	[Account Name]	Enter the account name.
	[Password]	Enter the account password.
	[Login]	To log in to this machine, you can press [Login] instead of the <b>Access</b> key.

### Reference

- To log out from the machine, press the **Access** key.
- For details on the authentication setting, refer to the [User's Guide Copy Operations].
- If [Password Only] has been selected for Account Track Input Method, only [Password] appears in the Authentication screen. If the password consists of numbers only, enter it using the **Keypad** without displaying the keyboard screen, and then press the **Access** key or [Login] to log in to this machine.

### 2.1.8 C (Clear)

Pressing the **C** key cancels the value entered using the **Keypad**.

→ Press the **C** key.

The value currently displayed in the **Touch Panel** is cleared. A new value can be entered.

### 2.1.9 Proof Copy

Pressing the **Proof Copy** key allows you to print a single proof copy and check it before printing a large number of copies. This prevents copy errors from occurring.

- ✓ This proof copy function is available only when you specify multiple sets of copies.

- 1 Load the original.
- 2 Press the **Proof Copy** key.

The original is scanned and a single proof copy is printed.

- If the original is placed on the **Original Glass**, pressing [Finish] ►► the **Start** key outputs one copy.

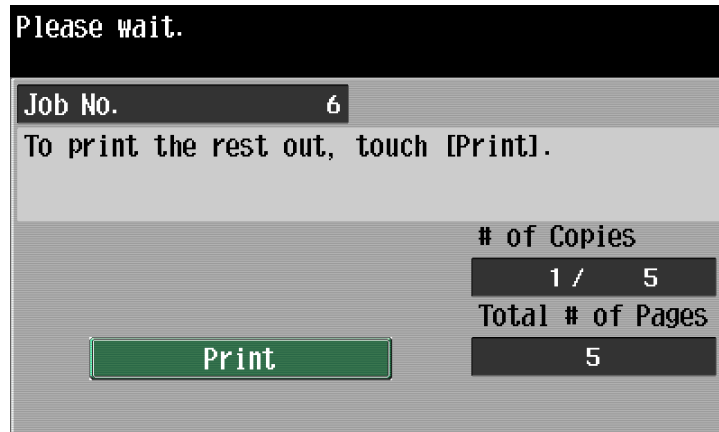

- 3 Check the proof copy.
  - To change the copy settings, press either the **C** key or the **Reset** key, and configure the settings again.
  - To print the remaining number of copies, press [Print].
  - If the system reset or auto reset function starts operating while proofing a copy, the job being proofed is registered as a stored job. For details on printing a stored job, refer to [User's Guide Copy Operations].

## 2.2 Loading originals

Place the original in the **ADF** or on the **Original Glass**. Select the optimal position for setting the original according to the type of the original to be copied.

- By using the **ADF**, a multi-page original can be fed automatically one page at a time. The ADF can also be used to automatically scan 2-sided originals.
- When you are using the **Original Glass**, place the original directly on the **Original Glass** to scan. This method is suited for originals in the form of a book and the like that cannot be fed through the **ADF**.

### Loading the original into the ADF

- 1 Slide the **Lateral Guide** to fit the size of the original.

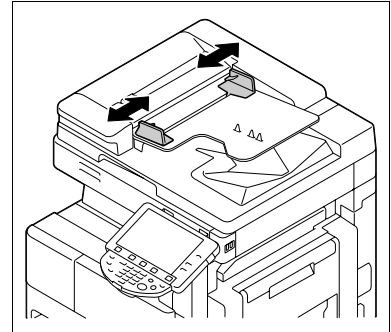

- 2 Load the original face up in the **Original Tray** and arrange according to the scanning order.

- Place the original pages so that the top of the original is toward the back side of the machine.
- Do not stack originals exceeding the ▼ mark.
- If the original is loaded in any orientation other than with the top of the original toward the back of the machine, be sure to select the original orientation.

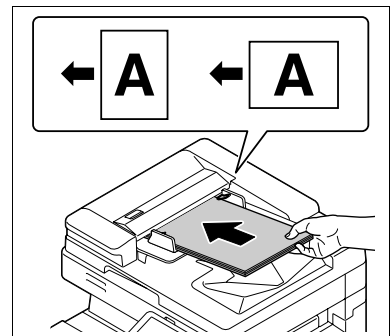

- 3 Slide the adjustable **Lateral Guide** against the edges of the original.

### Placing the original on the Original Glass

- 1 Lift open the **ADF** or the **Original Cover** 20 or more degrees.

- Unless you lift the ADF more than 20 degrees to open it, the correct original size may not be detected.

- 2 Place the original face down on the **Original Glass**.

- Place the original pages so that the top of the original is toward the back or the left side of the machine.
- Align the original with the mark in the back-left corner of the **Original Scale**. ↖
- For transparent or translucent originals, place a blank sheet of paper of the same size as the original over the original.

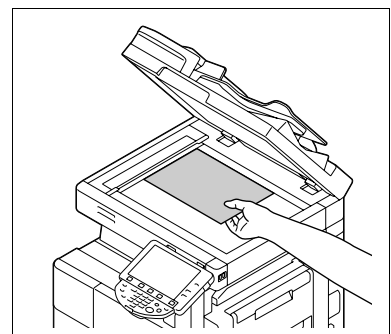

- 3 Close the **ADF** or **Original Cover**.



#### Reference

For details on originals that cannot be placed on the original glass or loaded into the **ADF**, refer to the [User's Guide Copy Operations].

---

A large, bold, black number '3' is centered within a gray square. The square is positioned to the left of the text 'How to use Copy mode'.

## How to use Copy mode

## 3 How to use Copy mode

This section describes the basic copy operations in the enlarge display mode.



### Reference

For details on the copy operation, refer to the [User's Guide Copy Operations].

### 3.1 General copy operation

The following describes the general operation for making copies.

- 1 Press the **Copy** key, and then the **Enlarge Display** key on the **Control Panel**.

The enlarged display screen for Copy mode appears.

- 2 Load the original.  
For details, refer to page 2-13.

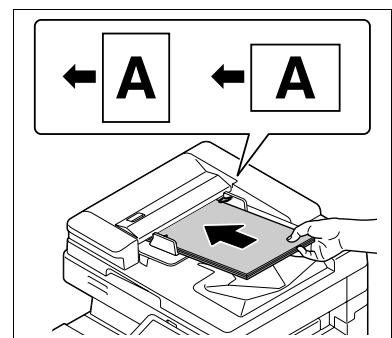

- 3 Configure the desired copy settings.

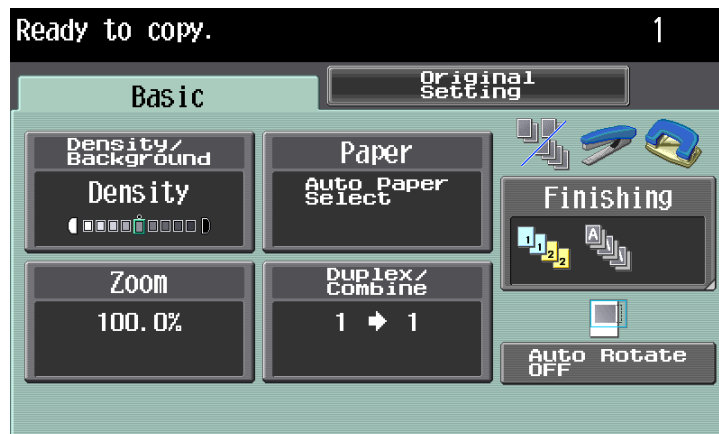

- For details on the Basic tab, refer to page 3-4.
- For details on Original Setting, refer to page 3-13.

- 4 Using the **Keypad**, enter the desired number of copies.

- If the number of copies was incorrectly entered, press the **C** (clear) key in the keypad, and then enter the correct number of copies.

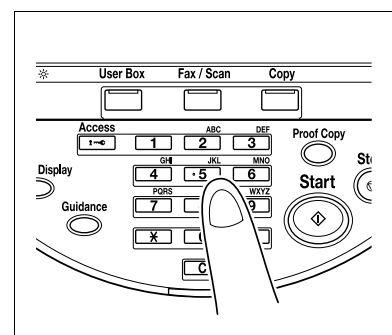

**5** Press the **Start** key.

The original is scanned and copied.

- To temporarily stop the copy operation, press the **Stop** key.
- If [Ready to accept another job.] appears while printing a job, you can scan the next original.

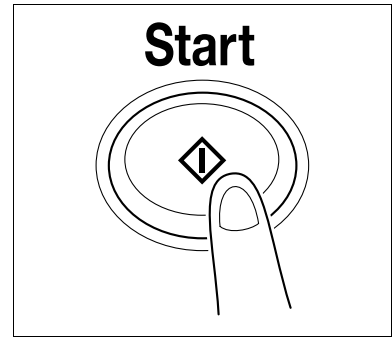

## Reference

- Some settings cannot be combined with each other. If they are combined improperly, the settings will be given priorities in either of the two ways described below.
  - The setting configured last is given priority. (The setting configured first is canceled.)
  - The setting configured first is given priority. (A warning message appears.)
- In User Settings, you can select to display [Next Copy Job]. For details, refer to [User's Guide Copy Operations].
- If an original with copy guard patterns embedded is scanned, the copy operation is stopped and the job is discarded.
- If an original with a password embedded by the password copy function is scanned, the copy operation starts after you enter the password.
- If multiple originals with different passwords are scanned at the same time, you will need to enter a password for each original.

## 3.2 [Basic]



Overview		Reference
[Density/Background]	Press this button to adjust the density of the copy or background according to the original condition.	p. 3-4
[Paper]	Press this button to configure the paper type and paper tray for making copies.	p. 3-6
[Zoom]	Press this button to select the zoom ratio of the image to be copied.	p. 3-7
[Duplex/ Combine]	Press this button to configure the double-sided copy and combined copy settings.	p. 3-8
[Finishing]	Press this button to select the settings for sorting and the finishing state of copies.	p. 3-10
[Auto Rotate OFF]	Select this item to copy the original according to the paper orientation without rotating the image.	p. 3-12

### 3.2.1 [Density]

Adjust the copy density according to the original condition. You can adjust the density of the background area for originals with colored background (newsprints, recycle paper, etc.) or originals on thin paper showing text or images from the back.

→ Press [Basic] ►► [Density/Background].

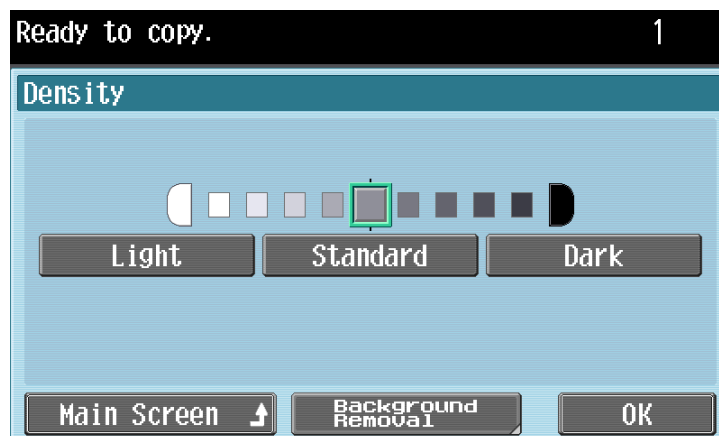

Settings	
[Light]	Each time this button is pressed, the density is lightened by one level.
[Standard]	Press this button to select the center setting (default setting).
[Dark]	Each time this button is pressed, the density is darkened by one level.

**Settings**

[Background Removal]	[Bleed Removal]	Select this setting to remove background prints of the original. Normally, select [Bleed Removal].	
	[Paper Discoloration Adj]	If the original to be scanned has a colored background, adjust the background with this button to remove it before copying.	
	[Background Removal Level]	[Light]	Each time this button is pressed, the background density is lightened by one level.
		[Standard]	Press this button to select the third level from the right (default).
		[Dark]	Each time this button is pressed, the background density is darkened by one level.
		[Auto]	The background density is detected automatically and adjusted to the optimal level. You can specify [Auto] for [Background Removal Level] only when [Standard] is selected for the density. Even if [Auto] is specified for [Background Removal Level], [Auto] is canceled for [Background Removal Level] if the density is selected to other than [Standard].
[Main Screen]	Press this button to return to the basic settings screen with the changed settings applied.		

### 3.2.2 [Paper]

Select the paper type and size to be printed or change the paper size and paper type settings configured for each paper tray.

- ✓ The auto zoom setting and the auto paper setting cannot both be selected at the same time.
- ✓ Be sure to specify the paper type when special paper is loaded into a paper tray.
- ✓ If the paper size or type is not correctly specified, a paper jam may occur or image quality may deteriorate.



→ Press [Basic] ►► [Paper].

















#### Settings

[Auto]	The paper size is automatically selected according to the original size.	
Trays [1] - [4]	Select the corresponding tray button to manually select the desired paper. <ul style="list-style-type: none"> <li>• The paper tray that is displayed varies depending on the installed options.</li> </ul>	
(Bypass Tray)		
[Change Settings]	Press this button to specify the paper type and size for the selected paper tray.	
	[Paper Type]	Specify the paper type for the selected paper tray. There are limits on the types of paper that can be loaded in a paper tray. <ul style="list-style-type: none"> <li>• A paper tray with the [Single Side Only] setting selected is given priority when the single-side printing is specified.</li> <li>• [Duplex 2nd Side] (only for <b>Bypass Tray</b>): Select this setting in combination with the paper type to print on paper with data printed on one side.</li> </ul>
	[Paper Size]	Specify the paper size for the selected paper tray. <ul style="list-style-type: none"> <li>• [Auto Detect]: Automatically detects the paper size.</li> <li>• [Inch Sizes] (only for <b>Bypass Tray</b>): Select the loaded paper size from the standard inch sizes.</li> <li>• [Metric Sizes] (only for <b>Bypass Tray</b>): Select the loaded paper size from the standard metric sizes.</li> <li>• [Other] (only for <b>Bypass Tray</b>): Select the loaded paper size from the standard sizes other than the standard metric and inch sizes.</li> <li>• [Custom Size] (only for <b>Bypass Tray</b>): Select the loaded paper size from the registered custom sizes. The Custom Size settings cannot be configured when no custom size is registered.</li> </ul>
[Main Screen]	Press this button to return to the basic settings screen with the changed settings applied.	

When very few sheets of paper remain in the paper tray, the icon indicating remaining paper quantities appears.

	Indicates that very little paper remains in the paper tray.
	Indicates that there is no paper in the paper tray.

When other than plain paper is loaded in the paper tray, the icon indicating the paper type appears.

[Single Side Only]	[Special Paper]	[Thick 1]	[Thick 2]	[Transparency]	[Letterhead]
					
[Colored Paper]	[Envelope]	[User Paper 1]	[User Paper 2]	[User Paper 3]	[User Paper 4]
					
[Duplex 2nd Side] [Plain Paper]	[Duplex 2nd Side] [User Paper 1]	[Duplex 2nd Side] [User Paper 2]			
					

#### Reference

- You can select User Paper when weighing capacity is specified by your service representative. For details on the user paper, refer to the [User's Guide Copy Operations].

### 3.2.3 [Zoom]

Image size in the original can be enlarged or reduced.

- ✓ The auto zoom setting and the auto paper setting cannot both be selected at the same time.
- ✓ The zoom ratio setting can be changed by the administrator settings.
- ✓ If the auto zoom setting is selected and an enlargement is to be copied on paper larger than the original, load the original with the same orientation as the paper.

→ Press [Basic] ► [Zoom].

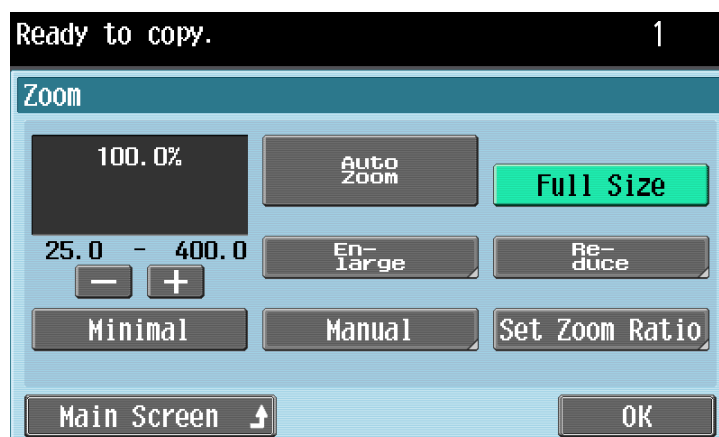

Settings	
[Auto]	The most appropriate zoom ratio is automatically selected based on the size of the loaded original and the specified paper size.
[Full Size]	A copy that is the same size as the original (100%) is produced.
[Enlarge]	Select the desired zoom ratio from the preset enlargement ratios to produce an enlarged copy.
[Reduce]	Select the desired zoom ratio from the preset reduction ratios to produce a reduced copy.
[Minimal]	An original image can be printed slightly smaller than the original size or zoom ratio that you have specified. The original image is centered without any part of the image being cropped. You can select this setting in combination with other specified zoom ratio.
[Manual]	Using the <b>Keypad</b> , enter the desired zoom ratio (between 25.0% and 400.0%).
[User Preset Zoom]	Select the desired zoom ratio from the preset zoom ratios to produce a copy.
[Main Screen]	Press this button to return to the basic settings screen with the changed settings applied.

### 3.2.4 [Duplex/Combine]

Single-sided or double-sided for both the original and the copy can be specified.

Also, multiple pages of original images can be combined and printed on a single page.

Using these functions helps to reduce the number of sheets of paper.

→ Press [Basic] ►► [Duplex/ Combine].

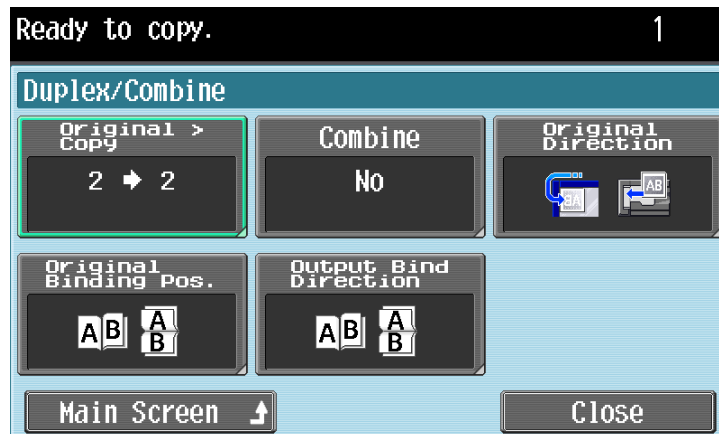

## Settings

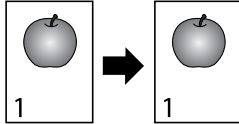
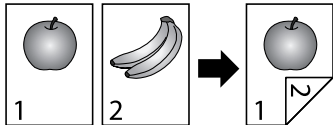
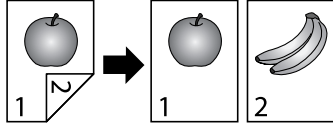
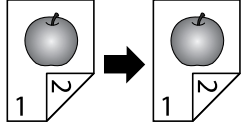
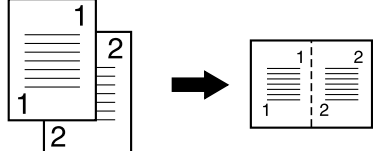
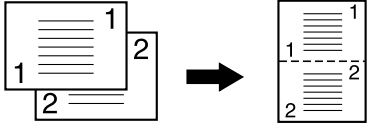
[Original > Copy]	[1 > 1]	
	[1 > 2]	
	[2 > 1]	
	[2 > 2]	
[Combine]	[2in1]	<p>Select this setting to print two original images on one sheet of paper.</p>  
	[No]	Select this setting to make no combined copy.
[Original Direction]	When scanning double-sided originals or configuring double-sided or combined copy settings, specify the direction of the original to be loaded. For details, refer to page 3-15.	
[Original Binding Pos.]	When you have selected [2 > 1] or [2 > 2], enter the original binding position. For details, refer to page 3-13.	
[Output Bind Direction]	<p>When you have selected [1 &gt; 2] or [2 &gt; 2], enter the copy binding position. This can arrange the images in the front page and back page in the correct orientation.</p> <ul style="list-style-type: none"> <li>[Auto]: The copy binding position is automatically set either at the top or at the left. A copy binding position along the long side of the paper is selected if the original length is 11-11/16 inches (297 mm) or less. A copy binding position along the short side of the paper is selected if the original length exceeds 11-11/16 inches (297 mm).</li> </ul>	
[Main Screen]	Press this button to return to the basic settings screen with the changed settings applied.	

### 3.2.5 [Finishing]

Various settings can be selected for sorting and finishing copies fed into the **Output Tray**.

- ✓ The staple function is available only if the optional **Finisher FS-527** or **Finisher FS-529** is installed.
- ✓ The Punch setting is available only if the **Punch Kit PK-517** is installed on the optional **Finisher FS-527**.
- ✓ The Half Fold and Center Staple & Fold functions are available only when the **Saddle Sticher SD-509** is installed on the optional **Finisher FS-527**.
- ✓ [Staple] cannot be used together with [Offset].
- ✓ [Half-Fold] and [Center Staple & Fold] cannot be used together with [Offset], [Staple], or [Punch].

→ Press [Basic] ►► [Finishing].

<When the **Finisher FS-527**, **Punch Kit PK-517**, or **Saddle Sticher SD-509** is installed>

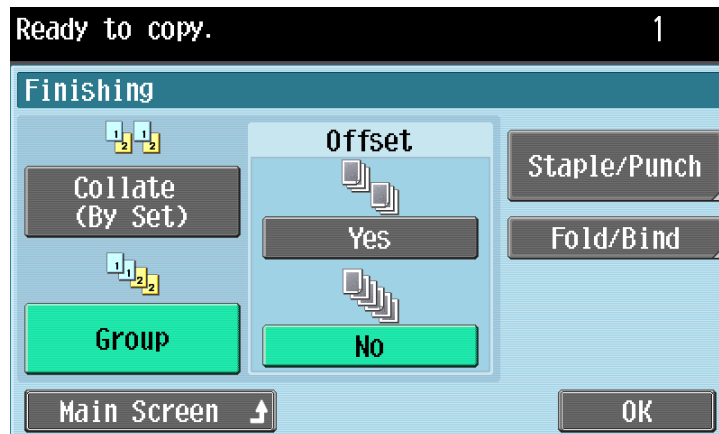

#### Reference

- The displayed window varies depending on the installed options.

#### Settings

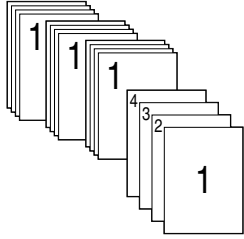
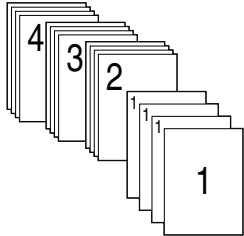
[Collate (By Set)]	<p>When multi-page originals are copied for multiple sets, copies can be fed out sorted by set of copies.</p> 
[Group]	<p>When multi-page originals are copied for multiple sets, copies can be fed out sorted by pages.</p> 

## Settings

[Offset]

Specify whether to separate each set of copies from another set in the output tray when copying multiple sets of multi-page originals.

- If **Finisher FS-527**, **Finisher FS-529**, or **Job Separator JS-505** is not installed:

If the following conditions are met, printed copies are fed out and sorted in an alternating crisscross pattern.

8-1/2 × 11 or A4 or B5-size paper is used.

Paper of the same size and type is loaded in the  direction and  direction.

The auto paper setting is selected in the paper/size function.

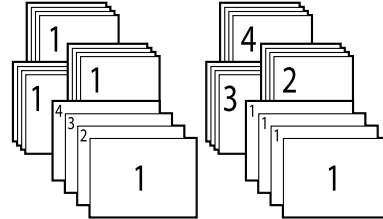

- If **Finisher FS-527**, **Finisher FS-529** or **Job Separator JS-505** is installed:

The copies are fed out and stacked on top of each other with each set staggered to separate them.

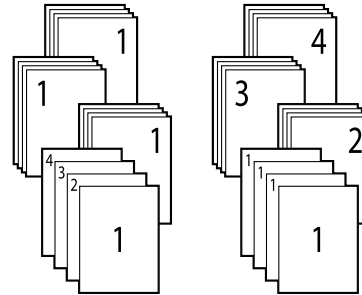

[Staple/Punch]

[Staple]:

Copies can be bound with a staple in the corner or with two staples.

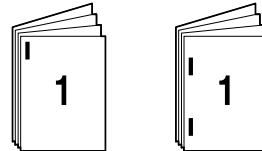

[Punch]:

Copies can be fed out hole-punched. The number of punched holes varies depending on the country you are in.

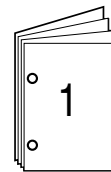

[Position Setting]

Select the desired staple or hole-punch position.

- [Auto]:  
The staple or hole-punch position is automatically set either at the top or at the left. A staple or punch position along the long side of the paper is selected if the original length is 11-11/16 inches (297 mm) or less. A staple or punch position along the short side of the paper is selected if the original length exceeds 11-11/16 inches (297 mm).
- If [Auto] is selected for the staple or hole-punch position, load the original with the top toward the back of the machine.
- If desired, press [Original Direction], and then select the original direction.

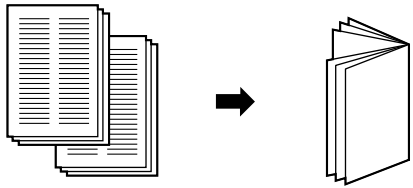
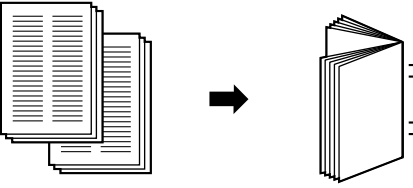
Settings		
[Fold/Bind]	[Half-Fold]	<p>Select this setting to fold copies at the center in half before feeding them out.</p> 
	[Center Staple and Fold]	<p>Select this setting to staple copies at the center before feeding them out.</p> 
[Main Screen]	Press this button to return to the basic settings screen with the changed settings applied.	



### Reference

For details on the paper that can be half-folded, center stapled & folded, stapled, and punched, refer to [User's Guide Copy Operations].

## 3.2.6 [Auto Rotate OFF]

You can copy the original according to the paper orientation without rotating the image.

- ➔ Press [Basic] ►► [Auto Rotate OFF].
  - ➔ To cancel the setting, press [Auto Rotate OFF] again to deselect it.

### 3.3 [Original Setting]



#### Overview

		Reference
[Binding Position]	Specify the original binding position (page margin) to prevent the copy from being printed upside-down when scanning a 2-sided original.	p. 3-13
[Original Type]	Select the setting for the image type of the original to better adjust the copy quality.	p. 3-14
[Original Direction]	When copying double-sided originals or making double-sided or combined copies, press this button to specify the direction in which the original is loaded into the <b>ADF</b> or placed on the <b>Original Glass</b> .	p. 3-15
[Mixed Original]	Loads originals of different sizes into the <b>ADF</b> and scan them at a time.	p. 3-16
[Z-Folded Original]	Correctly detects the original size when folded originals are loaded into the <b>ADF</b> and copied.	p. 3-17

#### 3.3.1 [Binding Position]/[Original Binding Pos.](Binding Position)

When you load double-sided originals, specify the binding position. The top of the back page of the original will be arranged in the correct orientation.

➔ Press [Original Setting] ➤ [Binding Position].

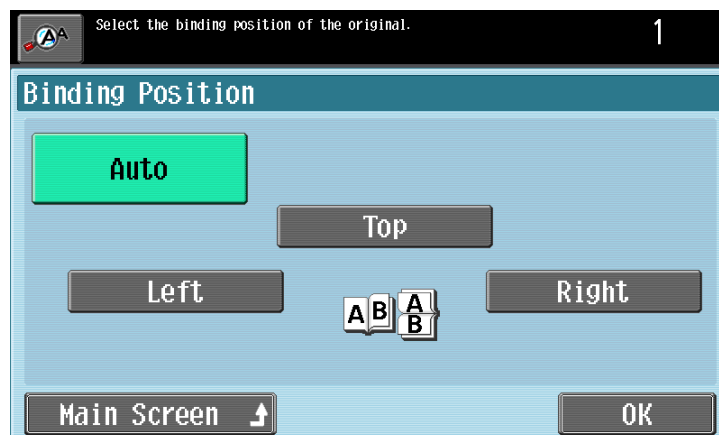

→ Alternatively, press [Basic] ►► [Duplex/ Combine] ►► [Original Binding Pos.].

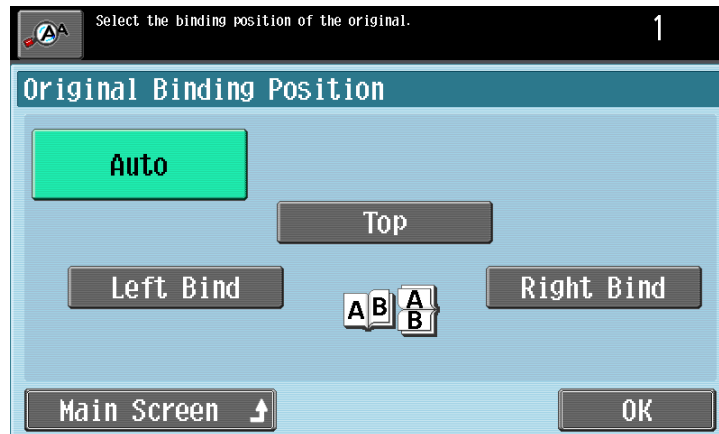

#### Settings

[Auto]	The page margin is automatically selected at the top or left of the original. A page margin position along the long side of the original is selected if the original length is 11-11/16 inches (297 mm) or less. A page margin position along the short side of the original is selected if the original length exceeds 11-11/16 inches (297 mm).
[Left] [Left Bind]	Select this setting if the original is loaded with the page margin at the left.
[Top] [Top]	Select this setting if the original is loaded with the page margin at the top.
[Right] [Right Bind]	Select this setting if the original is loaded with the page margin at the right.
[Main Screen]	Press this button to return to the basic settings screen with the changed settings applied.

### 3.3.2 [Original Type]

Select the original type (text and image type) to obtain better copy quality.

→ Press [Original Setting] ►► [Original Type].

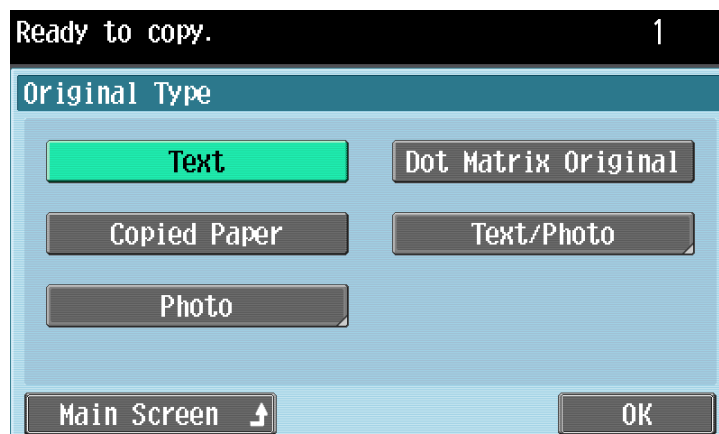

#### Settings

[Text]	Select this setting when copying documents containing only text. The edges of copied text are reproduced with sharpness, providing an image that is easy to read.
[Dot Matrix Original]	Select this setting when copying originals containing only text that appears faint (such as that written with a pencil). The copied text is reproduced so that it is darker, making it easier to read.

Settings	
[Copied Paper]	Select this setting to copy images (originals) printed using this machine.
[Text/Photo]	Select this setting when copying originals containing both text and photos. <ul style="list-style-type: none"> <li>[Photo Paper]: This setting is suitable for originals containing both text and photos and those photos are printed on photographic paper. A smooth copy image is produced.</li> <li>[Printed Photo]: Select this setting when copying printed originals containing both text and images, such as pamphlets or catalogs.</li> </ul>
[Photo]	Select this setting when copying originals containing only photos (half-tones). <ul style="list-style-type: none"> <li>[Photo Paper]: This setting is suitable when the photos on the originals are printed on photographic papers. Select this setting to produce better reproductions of halftone original images (photographs, etc.) that cannot be reproduced with the usual settings. A smooth copy image is produced.</li> <li>[Printed Photo]: Select this setting when copying printed originals, such as pamphlets or catalogs. Select this setting to produce better reproductions of halftone original images (photographs, etc.) that cannot be reproduced with the usual settings.</li> </ul>
[Main Screen]	Press this button to return to the basic settings screen with the changed settings applied.



### 3.3.3 [Original Direction]

When copying double-sided originals or making double-sided or combined copies, specify the direction in which the original is loaded. This can arrange the images in the front page and back page in the correct orientation with correct page order.

→ Press [Original Setting] ►► [Original Direction].

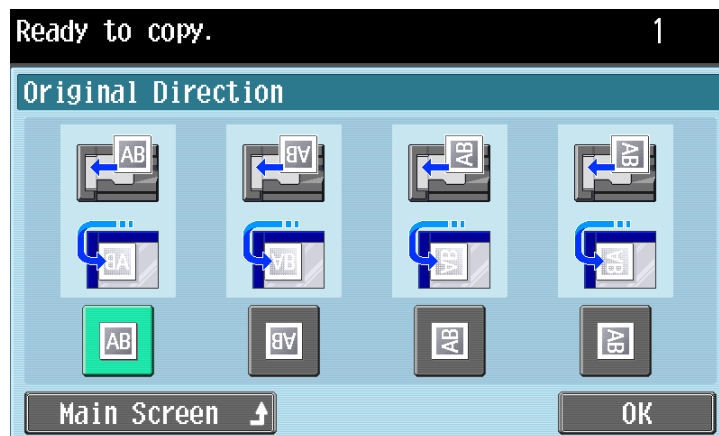
→ Alternatively, press [Basic] ►► [Duplex/ Combine] ►► [Original Direction].



Settings	
	Select this setting for an original loaded with the top toward the back of this machine.
	Select this setting for an original loaded with the top toward the front of this machine.
	Select this setting for an original loaded into the <b>ADF</b> with the top of the original toward the left side of this machine. Select this setting for an original placed on the <b>Original Glass</b> with the top of the original toward the right side of this machine.

## Settings

	<p>Select this setting for an original loaded into the <b>ADF</b> with the top of the original toward the right side of this machine. Select this setting for an original placed on the <b>Original Glass</b> with the top of the original toward the left side of this machine.</p>
[Main Screen]	Press this button to return to the basic settings screen with the changed settings applied.

## 3.3.4 [Mixed Original]

Originals of different sizes are loaded into the **ADF** and scanned at a time.

To copy onto the same paper sizes as the original, select [Full Size] in the Zoom screen and select [Auto] in the Paper screen. To copy all pages on the same size paper, select [Auto Zoom] in the Zoom screen and select the desired paper size in the Paper screen.

**NOTICE**

*Load all of the original pages into the **ADF** so that the top of the pages is toward the back or the left side of the machine.*

✓ [Mixed Original] is available only if the **ADF** is installed.

- 1 Slide the **Lateral Guide** of the **ADF** to fit the size of the largest page.
- 2 Load the original face up in the **ADF** and arrange according to the scanning order.

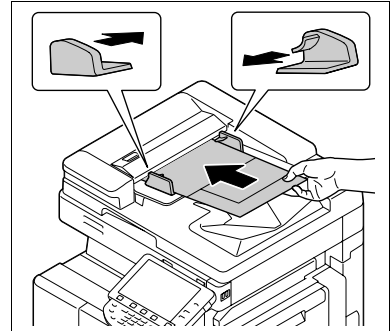

- 3 Press [Original Setting] ►► [Mixed Original].  
→ To cancel the setting, press [Mixed Original] again to deselect it.

**Reference**

*For details on combinations of standard paper available for mixed originals, refer to the [User's Guide Copy Operations].*

### 3.3.5 [Z-Folded Original]

Correctly detects the original size when folded originals are loaded into the **ADF** and copied.

#### **NOTICE**

*Unfold folded originals before loading them into the **ADF**. If the original is copied without being unfolded, a paper jam may occur.*

- ✓ The length of the first page of the original is detected, and all subsequent pages are scanned at that size.
- ✓ [Z-Folded Original] is available only when the **ADF** is installed.

**1** Load the original into the **ADF**.

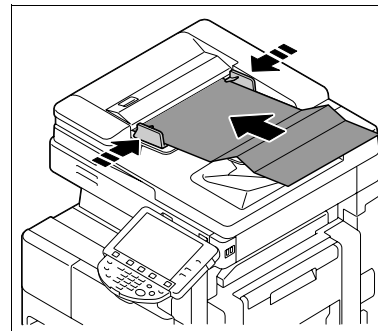

**2** Press [Original Setting] ►► [Z-Folded Original].

→ To cancel the setting, press [Z-Folded Original] again to deselect it.

#### Reference

- If you have configured settings before placing an original, a message appears prompting you to place an original.

---

# 4

## How to use Fax/Scan mode

## 4 How to use Fax/Scan mode

This section describes the basic fax/scan operations in the enlarge display mode.



### Reference

For details on the fax and scan operations, refer to the [User's Guide Network Scan/Fax/Network Fax Operations].

### 4.1 General fax/scan operation

The following describes the general fax/scan operation.

- ✓ Register addresses using the setting menu, and configure the fax and network settings and register addresses in Administrator Settings in advance.  
For details, refer to the [User's Guide Network Administrator] and the [User's Guide Network Scan/Fax/Network Fax Operations].

- 1 Press the **Fax/Scan** key, and then the **Enlarge Display** key on the **Control Panel**.

The enlarged display screen for Fax/Scan mode appears.

- 2 Load the original.  
For details on loading originals, refer to page 2-13.

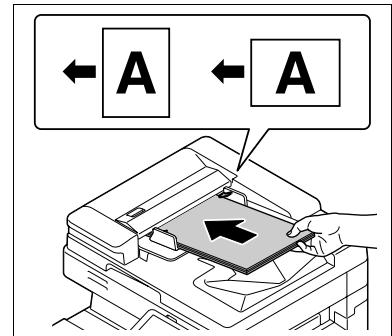

- 3 Specify the destination.



- For details on specifying a destination, refer to page 4-4.
- If the destination was incorrectly specified, press the **C** (clear) key, and then specify the destination again.

- 4 Configure the scan settings as needed.

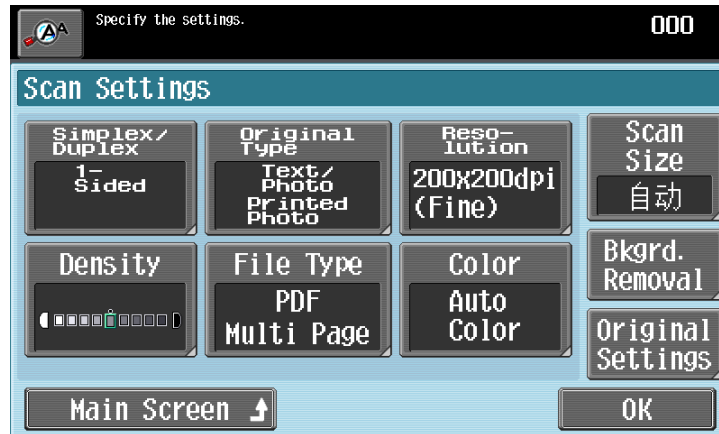

- For details on the scan settings, refer to page 4-9.
- To cancel the settings, press the **Reset** key, and then configure the settings again.

- 5 Press the **Start** key.

The original is scanned and the data is sent.

- To temporarily stop the scan operation, press the **Stop** key.

#### Reference

- Some settings cannot be combined with each other. If they are combined improperly, the settings will be given priorities in either of the two ways described below.
  - The setting configured last is given priority. (The setting configured first is canceled.)
  - The setting configured first is given priority. (A warning message appears.)
- If an original with copy guard patterns embedded is scanned, the scan operation is stopped and the job is discarded.
- If an original with a password embedded by the password copy function is scanned, the data is sent after you enter the password.
- If multiple originals with different passwords are scanned at the same time, you will need to enter a password for each original.

## 4.2 Configuring destinations

The following describes how to send scanned data and how to specify the destination.

### Transmission options

Send scanned data in one of the following ways.

Network scan function	E-Mail	Send scanned data to a specified E-mail address as a file attachment.
	FTP	In a network environment that contains an FTP server, send scanned data to the specified folder in the FTP server. This function is suitable to send a large amount of data such as high-resolution data.
	PC (SMB)	Scanned data will be sent directly to a specific computer on the network. To send a file by SMB, you must configure shared file settings in Windows on the computer receiving the data in advance.
	WebDAV	In a network environment that contains a WebDAV server, send scanned data to the specified folder in the WebDAV server. WebDAV, which is an extension to the HTTP specification, provides the same security technologies as HTTP. SSL-encrypted communication with the WebDAV server enhances file transmission security.
Fax function	Fax	Specify the destination fax number to send scanned data. You cannot send or receive color images.
Network fax function	Internet fax transmission	Send scanned data as an E-mail attachment (TIFF format) via the intranet (in-house network) or the Internet. Provide fax transmission in color, grayscale and black and white. This machine can also receive documents via Internet Fax and print them in black and white. Received documents in black can be printed, but received original data in color or grayscale are discarded and not printed.
	IP Address Fax	Send or receive faxes over the IP network. Specify the IP address (host name) or E-mail address of the destination to send scanned data. Fax transmission is limited within an intranet. Provide fax transmission in color, grayscale and black and white. This machine can also receive documents via IP Address Fax and print them in black and white.

#### Reference

- Network Fax function is available only when a **Hard Disk** is installed.

### Configuring the destinations

Configure the destinations in one of the following ways.



#### Reference

*To configure the destinations in the enlarged display screen, you must register destinations using the settings menu in advance. It is convenient to register fax recipients in advance as well.*

For details on registering destinations, refer to the [User's Guide Network Scan/Fax/Network Fax Operations].



Overview		Reference
[Address Book]	Select the desired destinations from the list of registered destinations in this machine.	p. 4-5
[Job History]	Select the desired destinations from the list of history data.	p. 4-6
[Address Search]	Search a destination registered on the LDAP server with keywords and conditions, and select the desired destination.	p. 4-7
[Fax Number]	Enter a fax number or registered number to specify the desired destination for sending a fax.	p. 4-8

#### Reference

- You can specify more than one destination at the same time.
- To manually send a fax, use [Off-Hook]. For details, refer to [User's Guide Network Scan/Fax/Network Fax Operations].
- [Off-Hook] is not used for Internet fax or IP address fax.
- If [Confirm Address (TX)] is specified in the Administrator Settings, [Off-Hook] cannot be used.
- If the optional **Security Kit SC-507** is installed, and [Security Details] - [Copy Guard] or [Password Copy] is set to [Yes] in Administrator Settings, [Off-Hook] is not displayed.

### 4.2.1 [Address Book]

Select the desired destinations from the list of registered destinations in this machine.

➔ Press [Address Book].



**Settings**

[Address Book]	The registered destinations appear as buttons, allowing you to select the desired destinations.
[Other Dest.]	Search the registered destinations in this machine for the desired destination by specifying the transmission method or destination name as search criteria. <ul style="list-style-type: none"> <li>• [Address Type]: Search for the desired destination based on the transmission method. You can select group destinations.</li> <li>• [Index]: Search for the destinations by specifying indexes that were specified when destinations were registered.</li> </ul>
[Scan Settings]	Configure various settings for scan operations. For details, refer to page 4-9.
[Check Address]	The selected destinations appear, allowing you to check the destinations before sending data. For details, refer to page 4-17.

**4.2.2 [Job History]**

Select the desired destinations from the list of previously sent destinations.

→ Press [Job History].

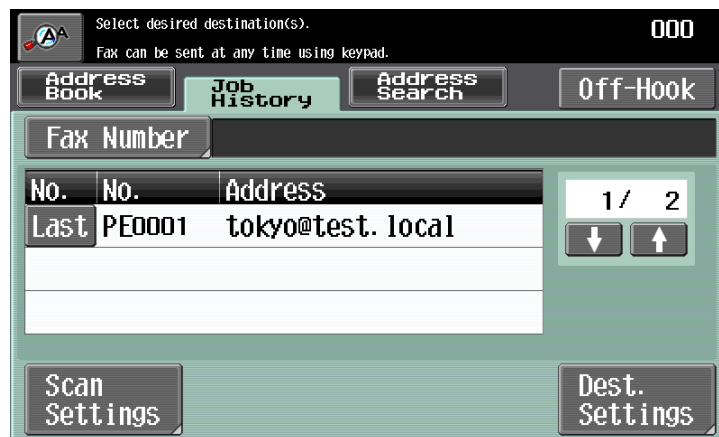
**Settings**

[Job History]	Up to 5 destinations that have been previously sent are listed on a most-recently-used-destination-first basis, allowing you to select the desired destination.
[Scan Settings]	Configure various settings for scan operations. For details, refer to page 4-9.
[Check Address]	The selected destinations appear, allowing you to check the destinations before sending data. For details, refer to page 4-17.

### 4.2.3 [Address Search]

Use this tab to search the LDAP server for registered destinations with keywords and conditions and select the desired destinations.

- ✓ To use this tab, you must enable LDAP and set up the LDAP server in Administrator Settings in advance. For details on the LDAP settings, refer to the [User's Guide Network Administrator].

→ Press [Address Search] ► [Search].



Press [Address Search] ► [Advanced Search].

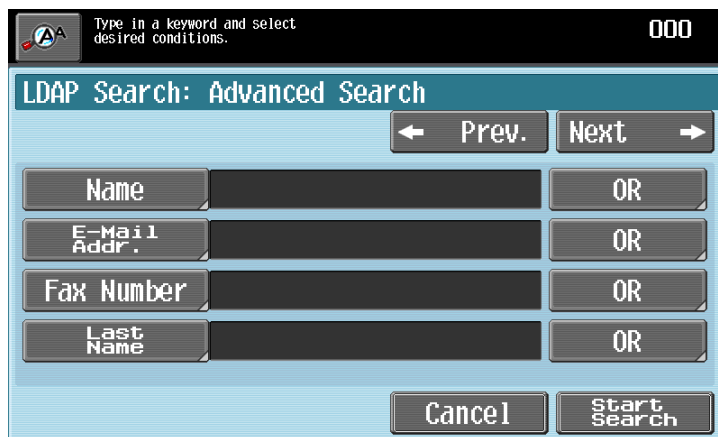

**Reference**

- If multiple LDAP servers are registered, select the server to be searched.
- Authentication may be necessary, depending on the LDAP server settings.

**Settings**

[Search]	Search for the destinations by entering a search keyword. Enter the keyword that indicates the registered items, such as name, E-mail address or fax number.	
[Advanced Search]	[Name]	Enter a search keyword for each item and select a condition from [OR], [AND], [STARTS WITH] or [ENDS WITH]. Multiple search items can be specified in combination.
	[E-Mail]	
	[Fax Number]	
	[Last Name]	
	[First Name]	
	[City]	
	[Company Name]	
	[Department]	

### 4.2.4 [Fax Number]

Enter a fax number or registered destination number to specify the desired destination for sending a fax to.

→ Press [Fax Number].

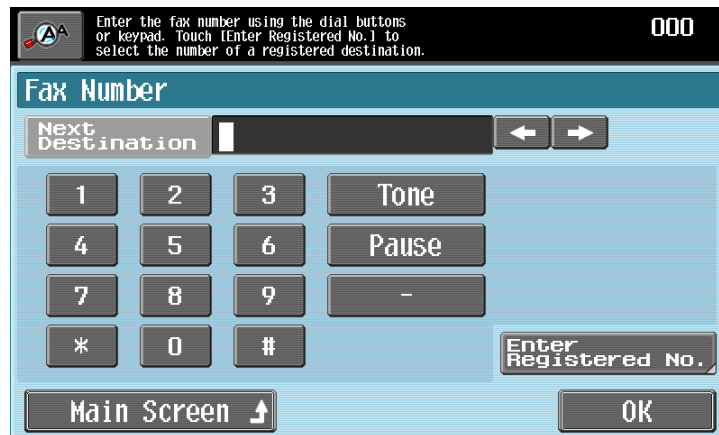

#### Settings

[Fax Number]	<p>Enter a fax number on the displayed screen or by using the <b>Keypad</b>. If you have entered an incorrect number, move the cursor to the character to be changed, press [Delete], and then enter the number again.</p> <ul style="list-style-type: none"> <li>• [Tone]: When using a dialing (pulse) telephone line, press this button for generating push-button tones. Use this function when using fax information services. When you press this button, [T] appears on the screen. From the dialing (pulse) telephone line, pressing [*] switches to the push-button tones.</li> <li>• [Pause]: Press this button to insert a pause in the dialing number. Pressing [Pause] once inserts one second of interval. You can also enter pauses successively. When you press this button, [P] appears on the screen. If the PBX (Private Branch eXchange) connection is enabled, to ensure the connection to the external line when calling from the in-house wiring, press [Pause] after the outside line access code such as [0]. [P] is displayed on the screen.</li> <li>• [-]: Press this button to separate a dial number. It does not affect the dialing of the number. When you press this button, [-] appears on the screen.</li> </ul>
[Next Destination]	Press this button to specify another destination after entering a fax number or a registered number.
[Enter Registered No.]	Press this button to display the Enter Registered No. screen. Enter a registered number using the <b>Keypad</b> , and press [Apply].
[Main Screen]	Press this button to return to the Address Book screen with the changed settings applied.

#### Reference

- If [Confirm Address (TX)] is enabled in Administrator Settings, the screen appears that prompts you to enter the fax number again after you enter a fax number.
- Fax numbers cannot be entered if [Manual Destination Input] is prohibited in Administrator Settings. For details on the [Manual Destination Input] setting, refer to the [User's Guide Network Administrator]. If user authentication is enabled, whether to permit [Manual Destination Input] is determined for each registered user. For details on user registration, refer to the [User's Guide Copy Operations].

## 4.3 [Scan Settings]

Configure the detailed original scan settings according to the original conditions and the purpose of sending data. It will help to send scanned data in the optimal condition.

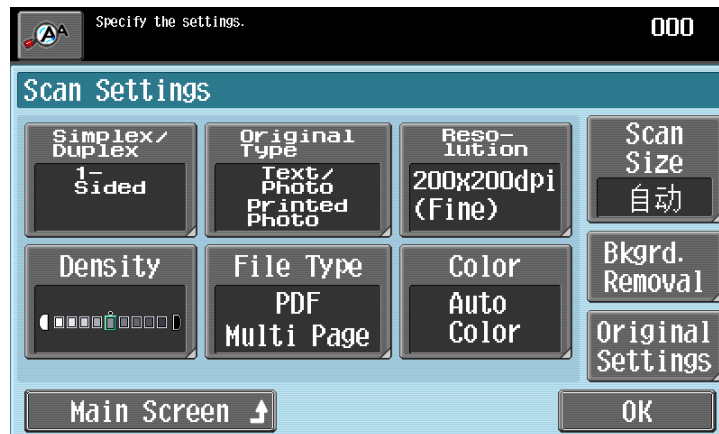

Overview		Reference
[Simplex/Duplex]	Select whether to scan one side or both sides of the original.	p. 4-9
[Original Type]	Select the image quality of the original according to the content of the original to be scanned.	p. 4-10
[Resolution]	Select the scan resolution of the original.	p. 4-11
[Density]	Adjust the scan density of the original.	p. 4-12
[File Type]	Select the file type used for saving the scanned data.	p. 4-12
[Color]	Select the scan color of the original.	p. 4-13
[Scan Size]	Select the scan size of the original.	p. 4-13
[Background Removal]	Adjust the settings for removing background if the original to be scanned has a colored background or so thin that text or images on its back would be scanned.	p. 4-14
[Original Settings]	Specify the direction in which the original is loaded. If double-sided originals are loaded, specify the binding position.	p. 4-15

### 4.3.1 [Simplex/Duplex]

Specify whether to scan one side or both sides of the original.

➔ Press [Scan Settings] ➡ [Simplex/ Duplex].

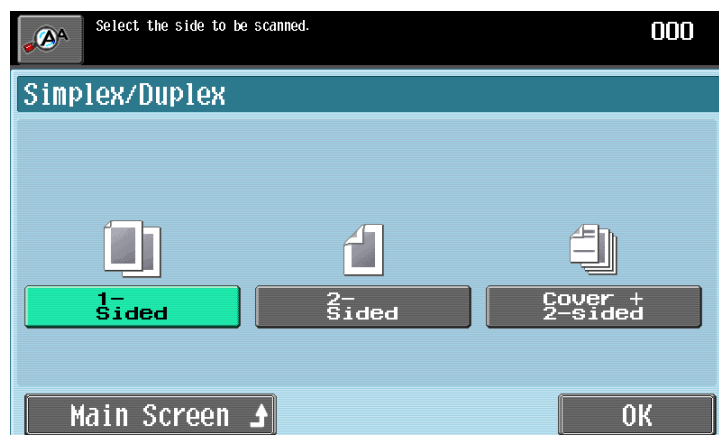

#### Settings

[1-Sided]	Select this setting to scan single-sided originals.
-----------	---

**Settings**

[2-Sided]	Select this setting to scan double-sided originals.
[Cover + 2-Sided]	Select this setting to scan only one side of the original for the first page as the front cover, and both sides of the original for the subsequent pages.
[Main Screen]	Press this button to return to the Address Book screen with the changed settings applied.

## Reference

- To scan a double-sided original, it is recommended that you also specify the direction in which the original is loaded. For details on the direction of the original, refer to page 4-15.

**4.3.2 [Original Type]**

The image quality of the original can be specified according to the content of the original to be scanned.

→ Press [Scan Settings] ►► [Original Type].

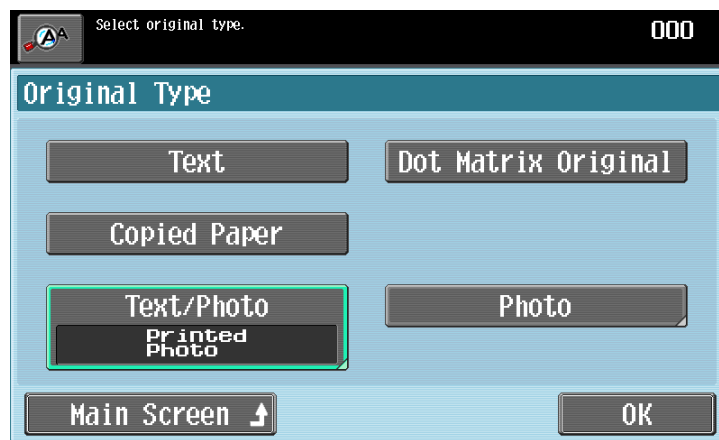
**Settings**

[Text]	Appropriate for scanning originals containing text only.
[Dot Matrix Original]	Appropriate for scanning originals with text that appears faint (such as that written with a pencil).
[Copied Paper]	Appropriate for scanning originals with an even density produced using a copier or printer.
[Text/Photo]	Appropriate for scanning originals consisting of both text and photos (half-tones). [Photo Paper]: This setting is suitable for originals containing both text and photos and those photos are printed on photographic paper. [Printed Photo]: This setting is suitable for scanning printed originals containing both text and images, such as pamphlets or catalogs.
[Photo]	Appropriate for scanning originals containing only photos (halftones). [Photo Paper]: This setting is suitable when the photos on the originals are printed on photographic papers. [Printed Photo]: This setting is suitable for scanning printed originals, such as pamphlets or catalogs.
[Main Screen]	Press this button to return to the Address Book screen with the changed settings applied.

### 4.3.3 [Resolution]

You can configure scan resolution of the original. The higher the resolution, the finer the scan image will be, resulting in larger file sizes.

→ Press [Scan Settings] ►► [Resolution].



#### Settings

[200 × 100 dpi (Standard)]	Select this setting to shorten the transmission time.
[200 × 200 dpi (Fine)]	Select this setting to scan originals of regular image quality.
[300 × 300 dpi]	Select this setting to scan originals of regular image quality in higher resolution.
[400 × 400 dpi (Super Fine)]	Select this setting to scan originals containing small typefaces or drawings.
[600 × 600 dpi (Ultra Fine)]	Select this setting to scan originals containing ultra fine images comprised of fine drawings or small typefaces.
[Main Screen]	Press this button to return to the Address Book screen with the changed settings applied.

#### Reference

- The finer the scan resolution is, the larger the data volume becomes, resulting in longer transmission time.  
To send data as an E-mail attachment or to a server, make sure the data volume does not exceed the limit.
- If [300 × 300 dpi] or [200 × 100 dpi (Standard)] is selected when sending a G3 or Internet fax, the resolution is automatically changed to 200 × 200 dpi before transmission.
- Even when you have selected [600 × 600 dpi (Ultra Fine)] or [400 × 400 dpi (Super Fine)] when sending a fax, if the recipient machine is not capable of receiving data with the specified resolution, the resolution is reduced accordingly.

### 4.3.4 [Density]

Adjust the scan density of the original.

→ Press [Scan Settings] ►► [Density].

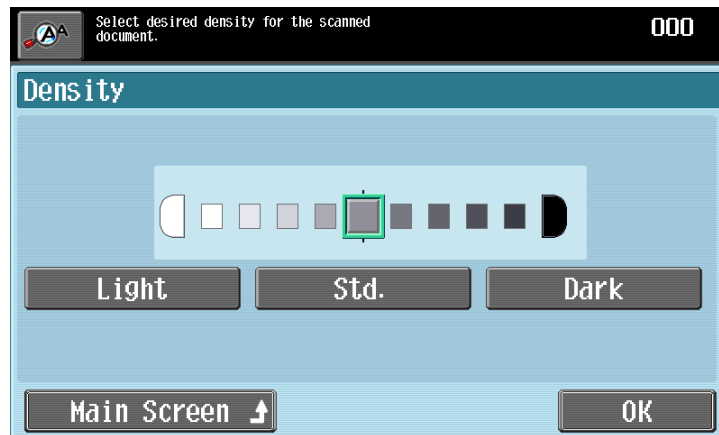

#### Settings

[Light]	Each time this button is pressed, the density is lightened by one level.
[Std.]	Press this button to reset the density to the default value.
[Dark]	Each time this button is pressed, the density is darkened by one level.
[Main Screen]	Press this button to return to the Address Book screen with the changed settings applied.

### 4.3.5 [File Type]

Select the file type used for saving the scanned data. You can specify the appropriate file format for the purpose for sending data.

- ✓ Some file format cannot be selected depending on the [Color] setting. For details on combining [File Type] and [Color], refer to the [User's Guide Network Scan/Fax/Network Fax Operations].
- ✓ The file type is fixed to TIFF for fax or Internet fax transmissions.

→ Press [Scan Settings] ►► [File Type].

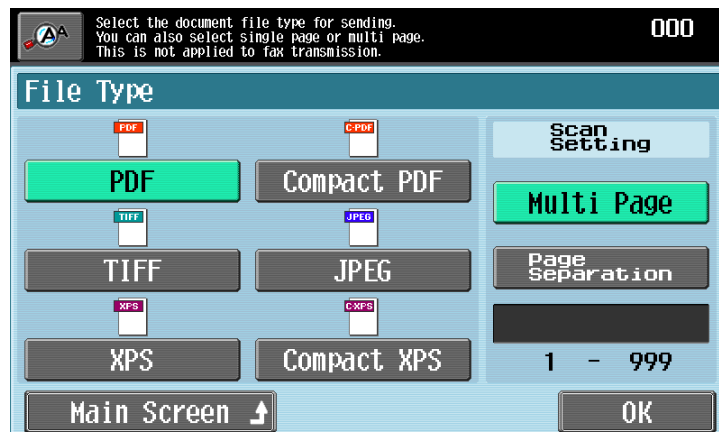

#### Settings

[PDF]	Select this setting to save data in PDF format.
[Compact PDF]	Select this setting to save data in a highly compressed PDF format. Use this setting to reduce the file size when scanned in full color.
[TIFF]	Select this setting to save data in TIFF format.
[JPEG]	Select this setting to save data in JPEG format.

Settings	
[XPS]	Select this setting to save data in XPS format.
[Compact XPS]	Select this setting to save data in a highly compressed XPS format. Use this setting to reduce the file size when scanned in full color.
[Multi Page]	Select this setting to send a single file containing all pages of the scanned original. You cannot select this setting and the JPEG file type at the same time.
[Page Separation]	Select this setting to send multiple files each containing the specified pages of the scanned original. Use the <b>Keypad</b> to enter the number of the pages to be saved in one file.
[Main Screen]	Press this button to return to the Address Book screen with the changed settings applied.

### 4.3.6 [Color]

Select the scan color of the original.

- ✓ Some color settings cannot be selected depending on the [File Type] setting. For details on combining [File Type] and [Color], refer to the [User's Guide Network Scan/Fax/Network Fax Operations].
- ✓ For fax transmissions, the color will always be set to [Black] even if you select a color.

→ Press [Scan Settings] ►► [Color].

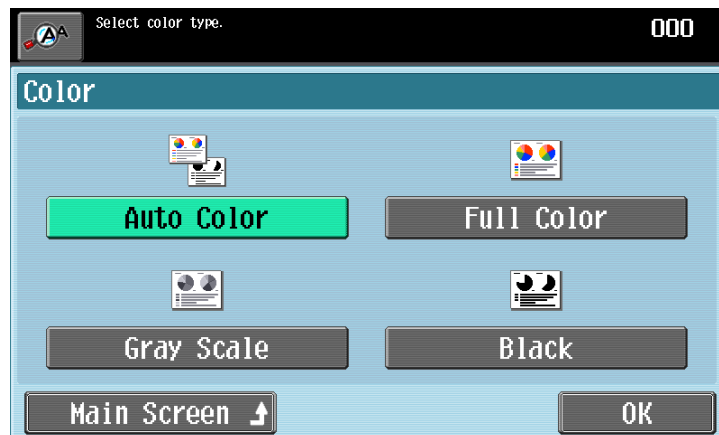

Settings	
[Auto Color]	Select this setting to automatically detect the color of the original and scan it with the corresponding setting.
[Full Color]	Select this setting to scan in full color.
[Gray Scale]	Appropriate for scanning originals with many halftones, such as black and white photos.
[Black]	Appropriate for scanning originals with distinct black and white areas, such as line drawings.
[Main Screen]	Press this button to return to the Address Book screen with the changed settings applied.

### 4.3.7 [Scan Size]

Select the scan size of the original. You can specify the scan size such as when scanning an irregular-sized original or part of a large original.

When sending data for example by fax, data can be sent at its original size if you do not wish to reduce the image size even though the paper width specified in the recipient's fax machine is smaller than the original size.

→ Press [Scan Settings] ►► [Scan Size].

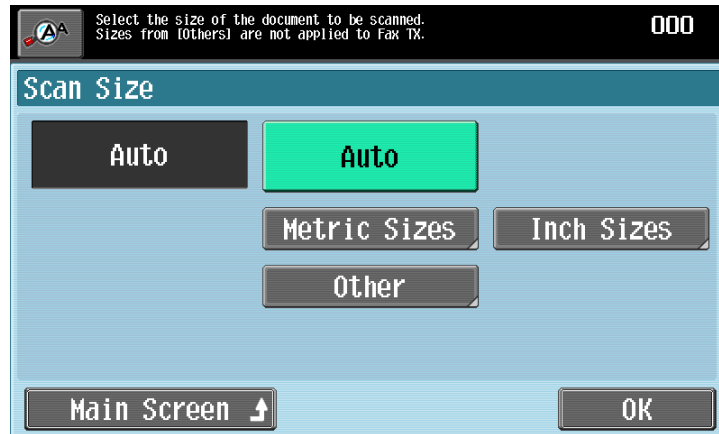

#### Settings

[Auto]	Select this setting to detect the size of the first page in the loaded originals.
[Metric Sizes]	Select the scan size from the standard metric sizes.
[Inch Sizes]	Select the scan size from the standard inch sizes.
[Other]	Select the scan size from the standard sizes other than standard metric or inch sizes.
[Main Screen]	Press this button to return to the Address Book screen with the changed settings applied.

### 4.3.8 [Background Removal]

You can adjust the density of the background area for originals with colored background (newsprints, recycle paper, etc.) or originals that are so thin that text or images on the back would be scanned.

→ Press [Scan Settings] ►► [Bkgrd. Removal].

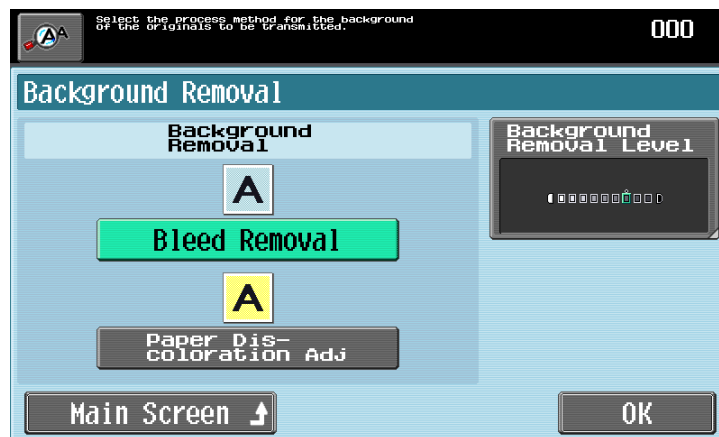

#### Settings

[Bleed Removal]	Select this setting to remove background prints of the original. Normally, select [Bleed Removal].
[Paper Discoloration Adj]	Select this setting to adjust the background density such as when the original to be scanned has a colored background.

**Settings**

[Background Removal Level]	[Light]	Each time this button is pressed, the background density is lightened by one level.
	[Standard]	Press this button to select the third level from the right (default).
	[Dark]	Each time this button is pressed, the background density is darkened by one level.
	[Auto]	The background density is detected automatically and adjusted to the optimal level.
[Main Screen]	Press this button to return to the Address Book screen with the changed settings applied.	

**4.3.9 [Original Settings]**





Specify the [Original Direction] and the [Binding Position]. You can specify the original direction and binding position in combination at a time.

**[Original Direction]**

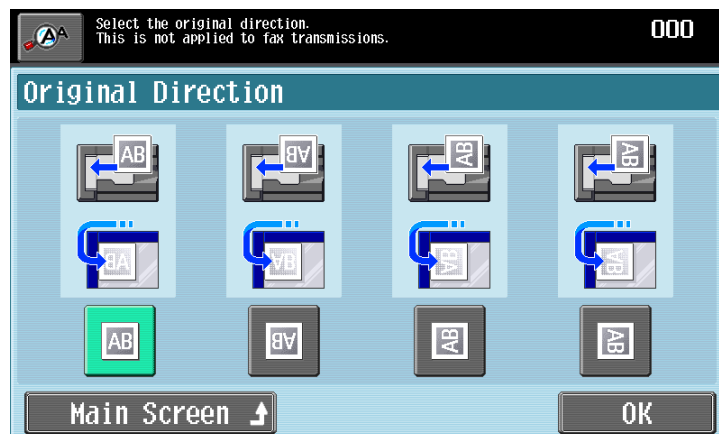
The vertical and horizontal orientations of the loaded original can be specified. The top of the back page of the original will be arranged in the correct orientation when scanning double-sided originals.

- ✓ The [Original Direction] setting will not be used for fax operations.
- ➔ Press [Scan Settings] ►► [Original Settings] ►► [Original Direction].

**Settings**

	Select this setting for an original loaded with the top toward the back of this machine.
	Select this setting for an original loaded with the top toward the front of this machine.
	Select this setting for an original loaded into the <b>ADF</b> with the top of the original toward the left side of this machine. Select this setting for an original placed on the <b>Original Glass</b> with the top of the original toward the right side of this machine.
	Select this setting for an original loaded into the <b>ADF</b> with the top of the original toward the right side of this machine. Select this setting for an original placed on the <b>Original Glass</b> with the top of the original toward the left side of this machine.

**Settings**

[Main Screen]	Press this button to return to the Address Book screen with the changed settings applied.
---------------	---

**[Binding Position]**

When you load double-sided originals, specify the binding position. The top of the back page of the original will be arranged in the correct orientation.

→ Press [Scan Settings] ►► [Original Settings] ►► [Binding Position].

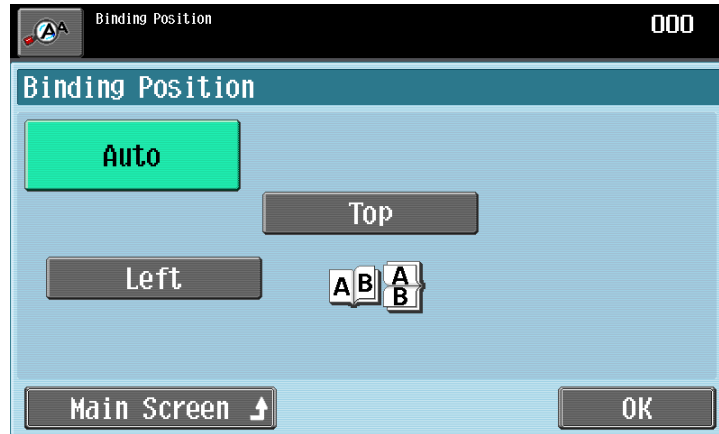
**Settings**

[Auto]	The binding position is automatically set to the top or left of the original. A page margin position along the long side of the original is selected if the original length is 11-11/16 inches (297 mm) or less. A page margin position along the short side of the original is selected if the original length exceeds 11-11/16 inches (297 mm).
[Left]	Select this setting if the original is loaded with the binding position at the left.
[Top]	Select this setting if the original is loaded with the binding position at the top.
[Main Screen]	Press this button to return to the Address Book screen with the changed settings applied.

## 4.4 [Destination Settings]

You can confirm the specified destinations before sending data.

→ Press [Dest. Settings].

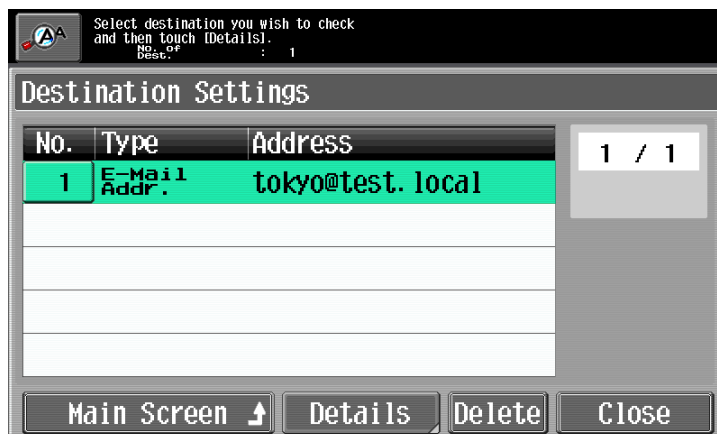

### Settings

[Check Address]	The configured destinations and their registration types are displayed in a list format.
[Details]	Select a destination and then press [Details] to display the details of the selected destination.
[Delete]	Select a destination to be deleted and then press [Delete] to delete it from the list.
[Main Screen]	Press this button to return to the Address Book screen with the changed settings applied.

---

**5** Index

# 5 Index

## 5.1 Index by item

### A

Access .....	2-10
Accessibility .....	2-8
Account track .....	2-10
Address book .....	4-5

### B

Background removal .....	4-14
Binding position .....	3-13, 4-16

### C

C .....	2-11
Center stapling/folding .....	3-10
Collating .....	3-10
Color .....	4-13
Configuring destinations .....	4-4
Configuring the basic settings .....	3-4
Control panel .....	2-2
Copy operation .....	3-2
Copying .....	2-5

### D

Default enlarge display settings .....	2-7
Density .....	3-4, 4-12
Destination settings .....	4-17
Duplex/combine .....	3-8

### E

Enlarge display .....	2-10
Entering fax numbers .....	4-8

### F

Fax/scan .....	2-6
Fax/scan operation .....	4-2
File type .....	4-12
Finishing .....	3-10

### G

Group .....	3-10
-------------	------

### I

Icon .....	2-10
------------	------

### J

Job history .....	4-6
-------------------	-----

### L

LDAP address search .....	4-7
Loading originals .....	2-13
Login .....	2-10

### M

Mixed original .....	3-16
Mode memory .....	2-7

### O

Offsetting .....	3-10
Original binding pos. ....	3-13
Original direction .....	3-15, 4-15
Original setting .....	3-13
Original type .....	3-14, 4-10

### P

Paper .....	3-6
Proof copy .....	2-12

### R

Reset .....	2-5
Resolution .....	4-11

### S

Scan settings .....	4-9
Scan size .....	4-13
Simplex/duplex .....	4-9
Stapling/punching .....	3-10
Start .....	2-5
Stop .....	2-5

### T

Touch panel .....	2-5
Transmission options .....	4-4
Turning off automatic rotation .....	3-12

### U

User authentication .....	2-10
Utility/counter .....	2-6

### Z

Z-folded original .....	3-17
Zoom .....	3-7

## 5.2 Index by button

### Numerics

1 > 1 .....	3-9
1 > 2 .....	3-9
1-Sided .....	4-9
2 > 1 .....	3-9
2 > 2 .....	3-9
2in1 .....	3-9
2-Sided .....	4-10

### A

Access .....	2-10
Accessibility .....	2-8
Account Name .....	2-11
Address Book .....	4-5
Address Search .....	4-7
Advanced Search .....	4-7
Auto Color .....	4-13
Auto Reset Confirmation .....	2-9
Auto Rotate OFF .....	3-12

### B

Background Removal .....	3-5, 4-14
Background Removal Level .....	3-5, 4-15
Basic .....	3-4
Binding Position .....	3-13, 4-16
Black .....	4-13
Bleed Removal .....	3-5, 4-14
Bypass tray .....	3-6

### C

C(clear) .....	2-11
Center stapling and folding .....	3-12
Collate (By Set) .....	3-10
Color .....	4-13
Combine .....	3-9
Compact PDF .....	4-12
Compact XPS .....	4-13
Copied Paper .....	3-15, 4-10
Copy .....	2-5
Cover + 2-Sided .....	4-10

### D

Default Enlarge Display Settings .....	2-7, 2-9
Density .....	3-4, 4-12
Destination Settings .....	4-17
Details .....	4-17
Dot Matrix Original .....	3-14, 4-10
Duplex 2nd Side .....	3-6
Duplex/Combine .....	3-8

### E

Enlarge .....	3-8
Enlarge Display .....	2-10
Enlarge Display Mode Confirmation .....	2-9
Enter Registered No. ....	4-8

### F

Fax Number .....	4-8
Fax/Scan .....	2-6
File Type .....	4-12
Finishing .....	3-10
Fold/Bind .....	3-12
Full Color .....	4-13
Full Size .....	3-8

### G

Gray Scale .....	4-13
Group .....	3-10

### H

Half-Fold .....	3-12
-----------------	------

### J

Job History .....	4-6
JPEG .....	4-12

### K

Key Repeat Start/Interval Time .....	2-9
--------------------------------------	-----

### L

Login .....	2-11
-------------	------

### M

Manual .....	3-8
Minimal .....	3-8
Mixed Original .....	3-16
Mode Memory .....	2-7
Multi Page .....	4-13

### N

Next Destination .....	4-8
------------------------	-----

### O

Off-Hook .....	4-4
Offsetting .....	3-11
Original > Copy .....	3-9
Original Binding Pos. ....	3-13
Original Direction .....	3-15, 4-15
Original Setting .....	3-13
Original Settings .....	4-15
Original Type .....	3-14, 4-10
Other Dest. ....	4-6
Output Bind Direction .....	3-9

### P

Page Separation .....	4-13
Paper .....	3-6
Paper Discoloration Adj .....	3-5, 4-14
Paper Size .....	3-6
Paper Type .....	3-6
Password .....	2-11
PDF .....	4-12
Photo .....	3-15, 4-10

Proof Copy .....	2-12
Public User Access .....	2-11

**R**

Reduce .....	3-8
Reset .....	2-5
Resolution .....	4-11

**S**

Scan Settings .....	4-9
Scan Size .....	4-13
Search .....	4-7
Server Name .....	2-11
Simplex/Duplex .....	4-9
Staple/Punch .....	3-11
Start .....	2-5
Stop .....	2-5
System Auto Reset Confirmation .....	2-9

**T**

Text .....	3-14, 4-10
Text/Photo .....	3-15, 4-10
TIFF .....	4-12
Tray 1 .....	3-6
Tray 2 .....	3-6
Tray 3 .....	3-6
Tray 4 .....	3-6

**U**

User Name .....	2-11
User Name List .....	2-11
User Preset Zoom .....	3-8
Utility/Counter .....	2-6

**W**

Wide Paper .....	3-6
------------------	-----

**X**

XPS .....	4-13
-----------	------

**Z**

Z-Folded Original .....	3-17
Zoom .....	3-7



**KONICA MINOLTA**

<http://konicaminolta.com>