

---

# **magicolor<sup>®</sup> 4690MF**

## **Reference Guide**

---

**A0FD-9563-00A**

**1800860-001A**

---

## Copyright Notice

The digitally encoded software and publication included with your machine are Copyrighted © 2008 by KONICA MINOLTA BUSINESS TECHNOLOGIES, INC., Marunouchi Center Building, 1-6-1 Marunouchi, Chiyoda-ku, Tokyo, 100-0005, Japan. All Rights Reserved.

This software may not be reproduced, modified, displayed, transferred, or copied in any form or in any manner or on any media, in whole or in part, without the express written permission of KONICA MINOLTA BUSINESS TECHNOLOGIES, INC.

No part of this publication may be reproduced, stored in a retrieval system, or transmitted in any form or by any means, electronic, mechanical, photocopying, recording, or otherwise, without the prior written permission of KONICA MINOLTA. The information contained in this guide is intended for use with the KONICA MINOLTA magicolor 4690MF machines only.

## Trademarks

KONICA MINOLTA and the KONICA MINOLTA logo are trademarks or registered trademarks of KONICA MINOLTA HOLDINGS, INC.

magicolor and PageScope are trademarks or registered trademarks of KONICA MINOLTA BUSINESS TECHNOLOGIES, INC.

All other trademarks and registered trademarks are the property of their respective owners.

## Notice

KONICA MINOLTA BUSINESS TECHNOLOGIES, INC. reserves the right to make changes to this guide and to the equipment described herein without notice. Considerable effort has been made to ensure that this manual is free of inaccuracies and omissions. However, KONICA MINOLTA BUSINESS TECHNOLOGIES, INC. makes no warranty of any kind including, but not limited to, any implied warranties of merchantability and fitness for a particular purpose with regard to this manual.

KONICA MINOLTA BUSINESS TECHNOLOGIES, INC. assumes no responsibility for, or liability for, errors contained in this manual or for incidental, special, or consequential damages arising out of the furnishing of this manual, or the use of this manual in operating the equipment, or in connection with the performance of the equipment when so operated.

---

# SOFTWARE LICENSE AGREEMENT

This package contains the following materials provided by Konica Minolta Business Technologies, Inc. (KMBT): software included as part of the printing system, the digitally-encoded machine-readable outline data encoded in the special format and in the encrypted form ("Font Programs"), other software which runs on a computer system for use in conjunction with the Printing Software ("Host Software"), and related explanatory written materials ("Documentation"). The term "Software" shall be used to describe Printing Software, Font Programs and/or Host Software and also include any upgrades, modified versions, additions, and copies of the Software.

The Software is being licensed to you under the terms of this Agreement.

KMBT grants to you a non-exclusive sublicense to use the Software and Documentation, provided that you agree to the following:

1. You may use the Printing Software and accompanying Font Programs for imaging to the licensed output device(s), solely for your own internal business purposes.
  2. In addition to the license for Font Programs set forth in Section 1 ("Printing Software") above, you may use Roman Font Programs to reproduce weights, styles, and versions of letters, numerals, characters and symbols ("Typefaces") on the display or monitor for your own internal business purposes.
  3. You may make one backup copy of the Host Software, provided your backup copy is not installed or used on any computer. Notwithstanding the above restrictions, you may install the Host Software on any number of computers solely for use with one or more printing systems running the Printing Software.
  4. You may assign its rights under this Agreement to an assignee of all of Licensee's right and interest to such Software and Documentation ("Assignee") provided you transfer to Assignee all copies of such Software and Documentation Assignee agrees to be bound by all of the terms and conditions of this Agreement.
  5. You agree not to modify, adapt or translate the Software and Documentation.
  6. You agree that you will not attempt to alter, disassemble, decrypt, reverse engineer or decompile the Software.
  7. Title to and ownership of the Software and Documentation and any reproductions thereof shall remain with KMBT and its Licensor.
  8. Trademarks shall be used in accordance with accepted trademark practice, including identification of the trademark owner's name. Trademarks can only be used to identify printed output produced by the Software. Such use of any trademark does not give you any rights of ownership in that trademark.
  9. You may not rent, lease, sublicense, lend or transfer versions or copies of the Software that the Licensee does not use, or Software contained on any unused media, except as part of the permanent transfer of all Software and Documentation as described above.
  10. In no event will KMBT or its licensor be liable to you for any consequential, incidental INDIRECT, PUNITIVE or special damages, including any lost profits or lost saving, even if KMBT has been advised of the possibility of such damages, or for any claim by any third party. KMBT or its licensor disclaims all warranties with regard to the software, express or implied, including, without limitation implied warranties of merchantability, fitness for a particular purpose, title and non-infringement of third party rights. Some states or jurisdictions do not allow the exclusion or limitation of incidental, consequential or special damages, so the above limitations may not apply to you.
-

11. Notice to Government End Users: The Software is a “commercial item,” as that term is defined at 48 C.F.R.2.101, consisting of “commercial computer software” and “commercial computer software documentation,” as such terms are used in 48 C.F.R. 12.212. Consistent with 48 C.F.R. 12.212 and 48 C.F.R. 227.7202-1 through 227.7202-4, all U.S. Government End Users acquire the Software with only those rights set forth herein.
12. You agree that you will not export the Software in any form in violation of any applicable laws and regulations regarding export control of any countries.

## OpenSSL Statement

### OpenSSL License

Copyright (c) 1998-2003 The OpenSSL Project. All rights reserved.

Redistribution and use in source and binary forms, with or without modification, are permitted provided that the following conditions are met:

1. Redistributions of source code must retain the above copyright notice, this list of conditions and the following disclaimer.
2. Redistributions in binary form must reproduce the above copyright notice, this list of conditions and the following disclaimer in the documentation and/or other materials provided with the distribution.
3. All advertising materials mentioning features or use of this software must display the following acknowledgment:

“This product includes software developed by the OpenSSL Project for use in the OpenSSL Toolkit. (<http://www.openssl.org/>)”

4. The names “OpenSSL Toolkit” and “OpenSSL Project” must not be used to endorse or promote products derived from this software without prior written permission. For written permission, please contact [openssl-core@openssl.org](mailto:openssl-core@openssl.org).
5. Products derived from this software may not be called “OpenSSL” nor may “OpenSSL” appear in their names without prior written permission of the OpenSSL Project.
6. Redistributions of any form whatsoever must retain the following acknowledgment:

“This product includes software developed by the OpenSSL Project for use in the OpenSSL Toolkit (<http://www.openssl.org/>)”

THIS SOFTWARE IS PROVIDED BY THE OpenSSL PROJECT “AS IS” AND ANY EXPRESSED OR IMPLIED WARRANTIES, INCLUDING, BUT NOT LIMITED TO, THE IMPLIED WARRANTIES OF MERCHANTABILITY AND FITNESS FOR A PARTICULAR PURPOSE ARE DISCLAIMED. IN NO EVENT SHALL THE OpenSSL PROJECT OR ITS CONTRIBUTORS BE LIABLE FOR ANY DIRECT, INDIRECT, INCIDENTAL, SPECIAL, EXEMPLARY, OR CONSEQUENTIAL DAMAGES (INCLUDING, BUT NOT LIMITED TO, PROCUREMENT OF SUBSTITUTE GOODS OR SERVICES; LOSS OF USE, DATA, OR PROFITS; OR BUSINESS INTERRUPTION) HOWEVER CAUSED AND ON ANY THEORY OF LIABILITY, WHETHER IN CONTRACT, STRICT LIABILITY, OR TORT (INCLUDING NEGLIGENCE OR OTHERWISE) ARISING IN ANY WAY OUT OF THE USE OF THIS SOFTWARE, EVEN IF ADVISED OF THE POSSIBILITY OF SUCH DAMAGE.

---

This product includes cryptographic software written by Eric Young (eay@cryptsoft.com). This product includes software written by Tim Hudson (tjh@cryptsoft.com).

## Original SSLeay License

Copyright (c) 1995-1998 Eric Young (eay@cryptsoft.com) All rights reserved.

This package is an SSL implementation written by Eric Young (eay@cryptsoft.com). The implementation was written so as to conform with Netscapes SSL.

This library is free for commercial and non-commercial use as long as the following conditions are aheared to. The following conditions apply to all code found in this distribution, be it the RC4, RSA, lhash, DES, etc., code; not just the SSL code.

The SSL documentation included with this distribution is covered by the same copyright terms except that the holder is Tim Hudson (tjh@cryptsoft.com).

Copyright remains Eric Young's, and as such any Copyright notices in the code are not to be removed. If this package is used in a product, Eric Young should be given attribution as the author of the parts of the library used. This can be in the form of a textual message at program startup or in documentation (online or textual) provided with the package.

Redistribution and use in source and binary forms, with or without modification, are permitted provided that the following conditions are met:

1. Redistributions of source code must retain the copyright notice, this list of conditions and the following disclaimer.
2. Redistributions in binary form must reproduce the above copyright notice, this list of conditions and the following disclaimer in the documentation and/or other materials provided with the distribution.
3. All advertising materials mentioning features or use of this software must display the following acknowledgement:

“This product includes cryptographic software written by Eric Young (eay@cryptsoft.com)”

The word 'cryptographic' can be left out if the rouines from the library being used are not cryptographic related.

4. If you include any Windows specific code (or a derivative thereof) from the apps directory (application code) you must include an acknowledgement:

“This product includes software written by Tim Hudson (tjh@cryptsoft.com)”

---

THIS SOFTWARE IS PROVIDED BY ERIC YOUNG "AS IS" AND ANY EXPRESS OR IMPLIED WARRANTIES, INCLUDING, BUT NOT LIMITED TO, THE IMPLIED WARRANTIES OF MERCHANTABILITY AND FITNESS FOR A PARTICULAR PURPOSE ARE DISCLAIMED. IN NO EVENT SHALL THE AUTHOR OR CONTRIBUTORS BE LIABLE FOR ANY DIRECT, INDIRECT, INCIDENTAL, SPECIAL, EXEMPLARY, OR CONSEQUENTIAL DAMAGES (INCLUDING, BUT NOT LIMITED TO, PROCUREMENT OF SUBSTITUTE GOODS OR SERVICES; LOSS OF USE, DATA, OR PROFITS; OR BUSINESS INTERRUPTION) HOWEVER CAUSED AND ON ANY THEORY OF LIABILITY, WHETHER IN CONTRACT, STRICT LIABILITY, OR TORT (INCLUDING NEGLIGENCE OR OTHERWISE) ARISING IN ANY WAY OUT OF THE USE OF THIS SOFTWARE, EVEN IF ADVISED OF THE POSSIBILITY OF SUCH DAMAGE.

The licence and distribution terms for any publically available version or derivative of this code cannot be changed. i.e. this code cannot simply be copied and put under another distribution licence [including the GNU Public Licence.]

---

---

# Contents

---

<b>1</b>	<b>Operation on Mac OS X .....</b>	<b>1</b>
	<b>System Requirements for the Printer Driver</b>	<b>2</b>
	<b>Installing the Printer Driver</b>	<b>3</b>
	Installing Ghostscript	3
	Installing the Printer Driver	7
	<b>Printer Setup Utility Settings</b>	<b>12</b>
	When Using a USB Connection	12
	When Using a Network Connection	15
	Bonjour Setting	15
	IP Printing Setting	18
	<b>Printer Settings (Mac OS X 10.5)</b>	<b>22</b>
	When Using a USB Connection	22
	When Using a Network Connection	26
	Bonjour Setting	26
	IP Printing Setting	29
	<b>Selecting Print Options</b>	<b>33</b>
	For Mac OS X 10.2/10.3/10.4	33
	For Mac OS X 10.5	35
	<b>Uninstalling the Printer Driver</b>	<b>37</b>
	<b>Specifying Page Setup Settings</b>	<b>39</b>

Page Attributes Options	40
Specifying Custom Paper Size	41
<b>Specifying Print Settings (Mac OS X 10.4)</b>	<b>42</b>
Print Dialog Box	42
Common buttons	43
Copies & Pages	44
Layout	45
Scheduler	46
Paper Handling	47
ColorSync	48
Cover Page	48
Paper Feed	49
Printer Features	50
Basic Features	51
Color Matching Options	52
Image Options	53
Watermark Selection	54
Watermark Orientation	55
Watermark Setting	56
Supply Levels	57
Summary	57
Using Additional Features (Mac OS X 10.3)	58
Booklet Printing	59
Fit to Paper	59
<b>Specifying Print Settings (Mac OS X 10.5)</b>	<b>61</b>
Print Dialog Box	61
Common buttons	62
Layout	63
Color Matching	64
Paper Handling	65
Paper Feed	66
Cover Page	67
Scheduler	68
Printer Features	69
Basic Features	69
Color Matching Option	70
Image Options	71
Watermark Selection	72
Watermark Orientation	73
Watermark Setting	74
Supply Levels	75
Summary	76
<b>System Requirements for the Scanner Driver</b>	<b>77</b>
<b>Installing the Scanner Driver</b>	<b>78</b>
Installing the Scanner Driver	78
<b>Scanning From a Computer Application</b>	<b>82</b>

Basic Scanning Operation	82
<b>Specify the Scan Settings</b>	<b>83</b>
Auto Scanning Mode	83
Manual Scanning Mode	85
<b>Troubleshooting</b>	<b>89</b>
<b>2 Using LinkMagic .....</b>	<b>93</b>
<b>About LinkMagic</b>	<b>94</b>
<b>LinkMagic Operating Environment</b>	<b>94</b>
<b>Before Using LinkMagic</b>	<b>95</b>
Installing LinkMagic	95
Starting Up LinkMagic	96
<b>Main LinkMagic Window</b>	<b>97</b>
<b>Using LinkMagic</b>	<b>99</b>
Saving Scanned Images as Files	99
Description of the Scan Image/Scan Document Dialog Boxes	100
Saving Scanned Images to the Clipboard	104
Description of the Scan to Clipboard Dialog Box	106
Attaching Scanned Images to an E-Mail Message	109
Description of the Scan and Mail Dialog Box	111
Printing Scanned Images	116
Description of the Scan and Print Dialog Box	118
Registering Frequently Used Software	122
Registering Software With Launcher Buttons	122
<b>Settings Dialog Box</b>	<b>124</b>
Push To Scan Tab	124
Launcher Tab	125
Other Tab	126
<b>Uninstalling LinkMagic</b>	<b>127</b>
<b>Troubleshooting</b>	<b>128</b>
<b>3 Using Local Setup Utility (LSU) .....</b>	<b>129</b>
<b>About Local Setup Utility (LSU)</b>	<b>130</b>
<b>LSU Operating Environment</b>	<b>130</b>
Installing LSU	131
Starting Up LSU	132
<b>Main LSU Window</b>	<b>133</b>
Connecting to the Machine	133
Downloading Information from the Machine	134
Uploading Information to the Machine	134
Dial Import/Dial Export	134
<b>Registering Dialing Settings</b>	<b>135</b>
Programming a Speed Dial Number	135
Adding a Speed Dial Number (Fax/E-mail)	136
For registering a fax number	136
For registering an E-mail address	137

Adding a Speed Dial Number (Scan To Server)	137
For FTP transmissions	137
For SMB transmissions	138
Editing a Speed Dial Number	138
Deleting a Speed Dial Number	138
Programming/Editing a Group Dial	139
Registering to Favorites	140
Printing the List of Speed Dial, Group Dial and Favorite	142
Displaying Machine Information	143
Checking the Total Counter	143
Checking the Configuration Page	144
Uninstalling LSU	145
<b>Troubleshooting</b>	<b>146</b>
<b>4 Printer Utilities</b>	<b>147</b>
<b>Installing Printer Utilities on Windows</b>	<b>148</b>
<b>5 Understanding the Network Configuration Menus</b>	<b>149</b>
<b>ADMIN. MANAGEMENT Menu</b>	<b>150</b>
Location within the Configuration Menu	150
Accessing the Network Setting Menu	154
Using the Network Setting Menu Options	154
TCP/IP	154
IP ADDR. SETTING	155
DNS CONFIG.	156
DHCP	157
BOOTP	157
ARP/PING	157
HTTP	157
FTP	158
SMB	158
BONJOUR	158
IPP	158
SLP	159
SNMP	159
SPEED/DUPLEX	159
<b>6 Network Printing</b>	<b>161</b>
<b>Network Connection</b>	<b>162</b>
Theory	162
Making the Connection	163
Ethernet Interface	163
Using DHCP	163
Setting the Address Manually	164
<b>Network Printing</b>	<b>166</b>
Bonjour	166

BOOTP	166
DHCP	167
DNS	167
FTP	167
HTTP	167
IPP	167
LDAP	168
LPD/LPR	168
POP Before SMTP	168
Port 9100	168
SLP	168
SMB	169
SMTP	169
SMTP Authentication	169
SNMP	169
TCP/IP	170
Printing via IPP (Internet Printing Protocol) – Windows Server 2003/XP/2000	171
Adding an IPP Port using Add Printer Wizard	171
Printing via IPP (Internet Printing Protocol) - Windows Vista	173
Adding an IPP Port using Add Printer Wizard	173
<b>7 Using PageScope Web Connection .....</b>	<b>175</b>
<b>About PageScope Web Connection</b>	<b>176</b>
Requirements	176
<b>Setting Up the Printer Web Page</b>	<b>177</b>
Determining the Printer Name	177
Setting Up Your Browser Software	177
Internet Explorer (version 6.0 for Windows)	178
Safari (version 2.0)	178
<b>Understanding the PageScope Web Connection Window</b>	<b>179</b>
Navigation	179
Current Status	180
User Mode	180
Administrator Mode	180
<b>Configuring the Machine for User Mode</b>	<b>181</b>
System Page	181
Device Information	181
Counter	186
Online Assistance	188
Scan Page	189
Favorite (shown above)	189
Speed Dial Setting	190
Group Dial Setting	191
Network Page	192
Summary (shown above)	192

**Configuring the Printer 193**

System Page 193

Device Information 193

Preference 199

Save Setting 201

Machine Setting 202

Maintenance 204

Counter 206

Online Assistance 208

Date/Time 210

Scan Page 212

Favorite (shown above) 212

Speed Dial Setting 216

Group Dial Setting 231

Fax Configuration 235

Downloading/Uploading Destination List 244

Network 245

Summary (shown above) 245

TCP/IP 246

LDAP 255

IPP 259

SNMP 262

E-mail 264

FTP 269

SMB 270

---

***Operation on  
Mac OS X***

---

**1**

---

# System Requirements for the Printer Driver

Before installing the printer driver, make sure that your system meets the following system requirements.

Computer	Apple Macintosh computer installed with the following processor: <ul style="list-style-type: none"><li>– PowerPC G3 or later processor (PowerPC G4 or later is recommended)</li><li>– Intel processor</li></ul>
Connecting the computer and printer	USB connection, Network connection (10Base-T/100Base-TX)
Operating system	Mac OS X 10.2.8 or later
RAM	128 MB or more
Available disk space	256 MB or more (for storing images)
Supported languages	English, French, German, Italian, Spanish, Portuguese, Russian, Czech, Slovak, Hungarian, Polish, Japanese, Korean, Simplified Chinese, Traditional Chinese, Arabic

# Installing the Printer Driver



You must have administrator privileges in order to install the printer driver.



Before proceeding with the installation, be sure to exit all running applications.



In the following text, “TWAIN driver” may be used to indicate the scanner driver.

## Installing Ghostscript

If you are using Mac OS 10.3 or later, skip to “Installing the Printer Driver” on page 7. If you are using Mac OS 10.2, you must first use the following procedure to download and install Ghostscript before you install the printer driver.

1

The latest version of Ghostscript can be downloaded from [http://sourceforge.net/project/show-files.php?group\\_id=18073#&package\\_id=19793](http://sourceforge.net/project/show-files.php?group_id=18073#&package_id=19793).



Here we explain how to install the software from the **espgs-7.05.5-0.ppc.dmg** disk image file.

2

Double click the **espgs-7.05.5-0.ppc.dmg** file. The disk image **Install ESP Ghostscript 7.05.5** appears on the desktop.

3

Double click the **ESP Ghostscript.mpkg** package file in the disk image.

4

Enter the administrator user name and password in the **Authenticate** dialog box, and then click **OK**.

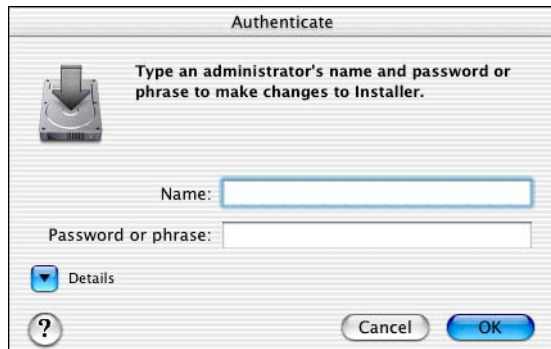

5 Click **Continue**.

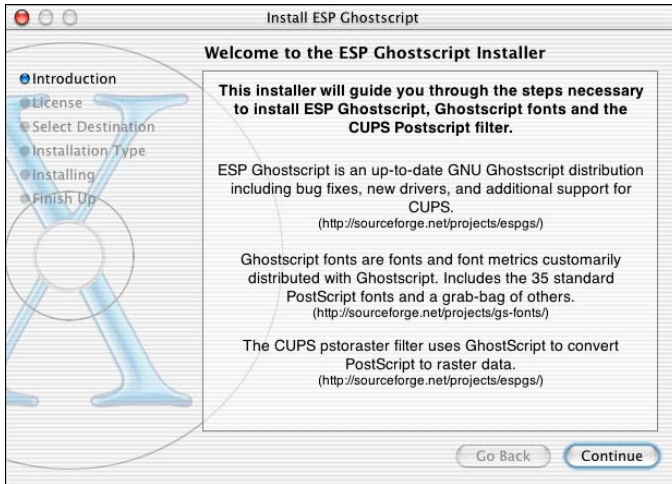

6 Check the details of the license agreement and click **Continue**.

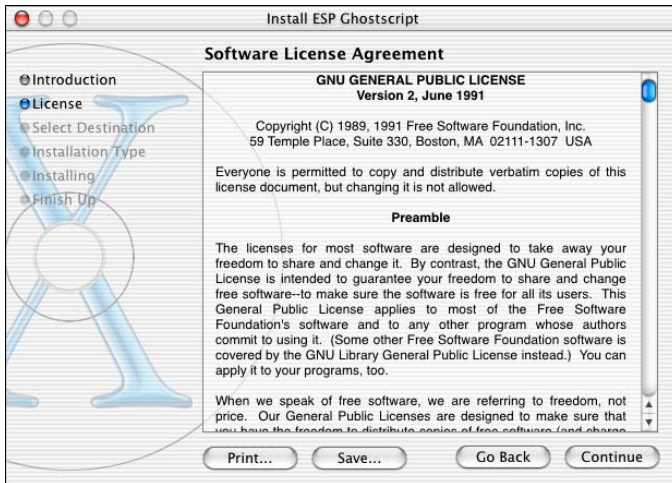

- 7 Click **Agree** in the confirmation dialog box, if you agree to the terms of the license.

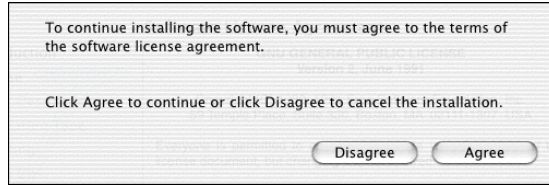

- 8 In the **Select a Destination** page, select the disk in which you wish to install the software, and then click **Continue**.

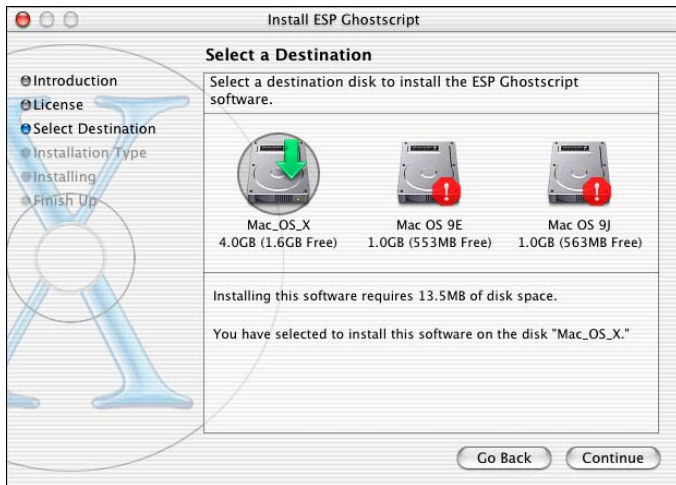

9 Click **Install** in the **Easy Install** page.

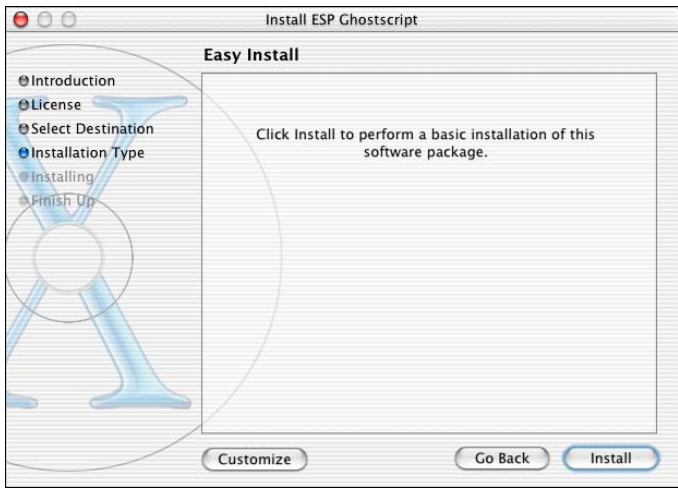

*Installation starts.*

10 After the installation has been completed, click **Close**.

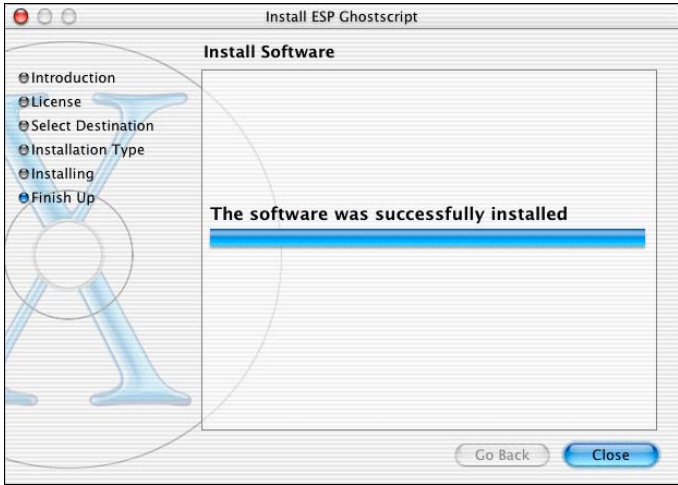

This completes the installation of Ghostscript.

## Installing the Printer Driver



The procedure for installing the printer driver on Mac OS X 10.4 is described below. The following procedure or some steps may be different depending on the version of the operating system being used. Complete the installation according to the instructions in the dialog boxes that appear.

- 1 Insert the Drivers CD/DVD in the CD/DVD-ROM drive of your Macintosh.
- 2 Double-click the CD icon on the desktop, Mac folder, Printer Driver folder, and then double-click the **magicolor 4690MF.pkg**.

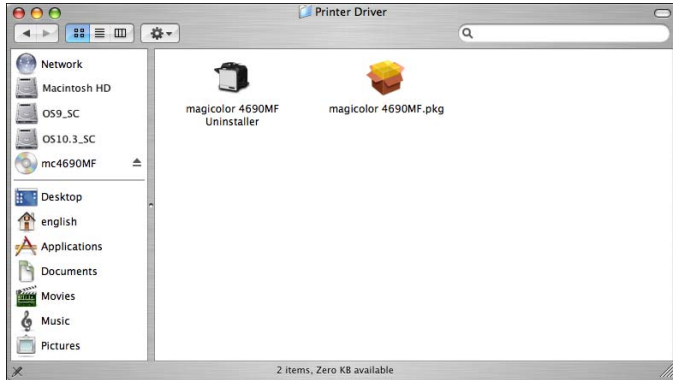

The installer for the printer driver starts up.

- 3 Click **Continue**.

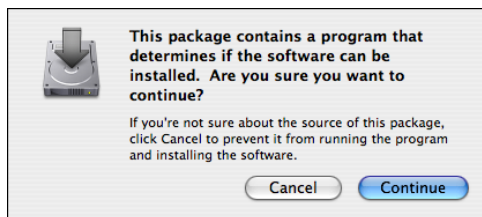

#### 4 Click **Continue**.

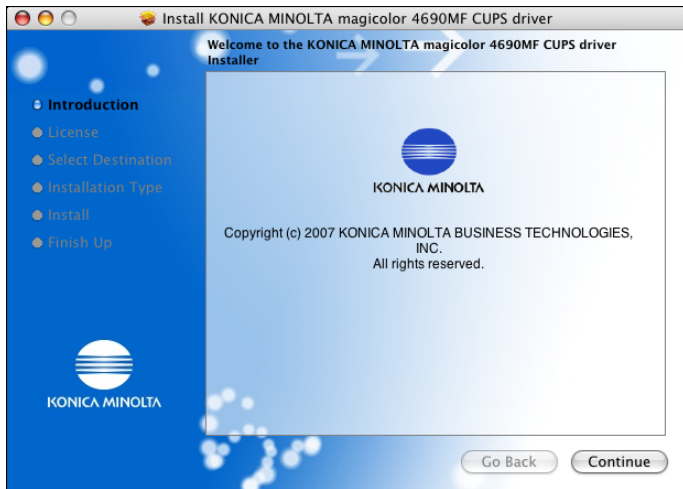

#### 5 Check the details of the license agreement, and then click **Continue**.



- 6 Click **Agree** in the confirmation dialog box if you agree to the terms of the license.



- 7 In the **Select a Destination** page, select the disk in which you wish to install the software, and then click **Continue**.

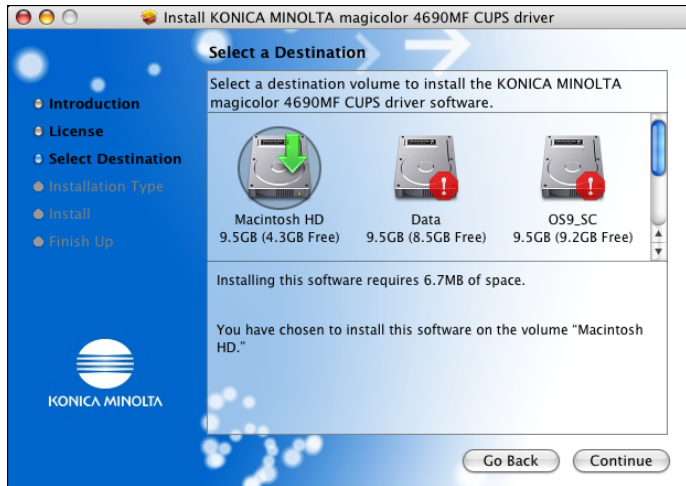

- 8 Click **Install** in the **Easy Install** page.

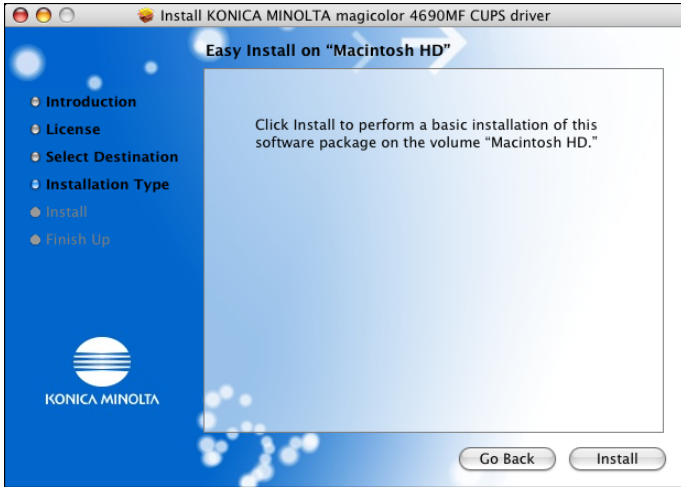

- 9 Enter the administrator user name and password in the Authenticate dialog box, and then click **OK**.



*Installation starts.*

10 After the installation has been completed, click **Close**.

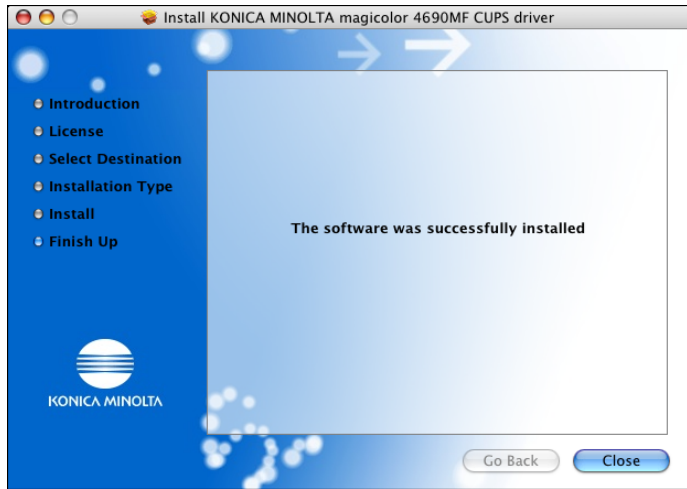

*This completes the installation of the printer driver.*

# Printer Setup Utility Settings



Before specifying the Printer Setup Utility settings, set **USB SETTING** (in the **UTILITY - ADMIN. MANAGEMENT** menu) to **Mac**. For details, refer to the *Printer/Copier/Scanner User's Guide on the Documentation CD/DVD*.

## When Using a USB Connection

- 1 Use a USB cable to connect the machine to your computer.
- 2 Open **Printer Setup Utility**, which can be accessed by clicking Macintosh HD, then **Applications**, then **Utilities**.
- 3 In the **Printer List**, click **Add**.

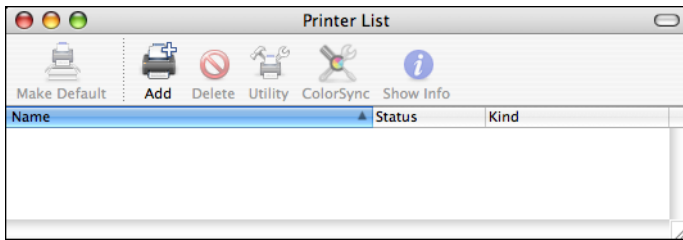

The detected printer appears in the **Printer Browser**.

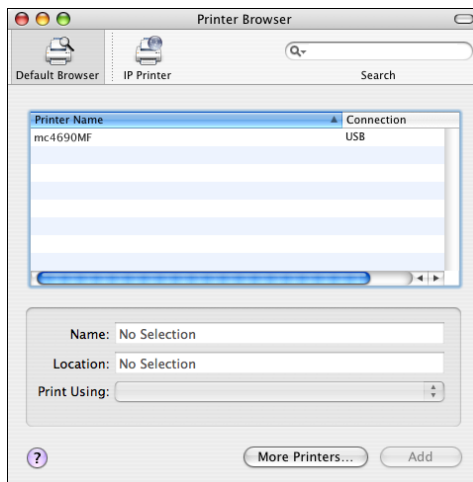

**4** Select **mc4690MF** in the **Printer Name**.

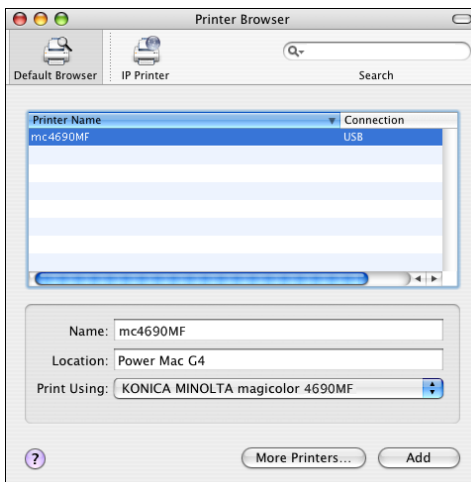

 *If **mc4690MF** does not appear, check that the machine is turned on and the USB cable is connected, and then restart the computer.*

**5** Check that **KONICA MINOLTA magicolor 4690MF** is selected in the **Print Using** list.

**6** Click **Add**.

**7** Select **Optional Trays** to match your printer setup, and then click **Continue**.



The new printer appears in the **Printer List** screen.

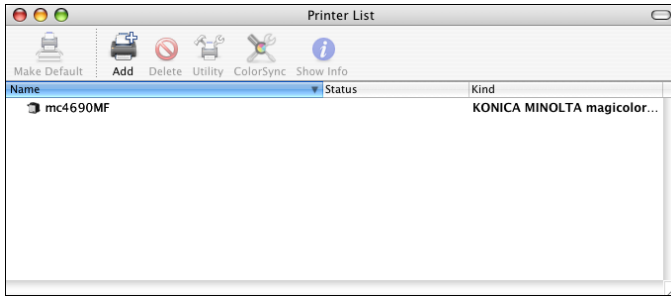

## When Using a Network Connection

The network connection settings can be specified in one of two ways: Bonjour setting and IP printing setting (IPP, LPD or Socket).

### Bonjour Setting

- 1 Connect the machine to an Ethernet network.
- 2 Open **Printer Setup Utility**, which can be accessed by clicking Startup Disk, then **Applications**, then **Utilities**.
- 3 In the **Printer List**, click **Add**.

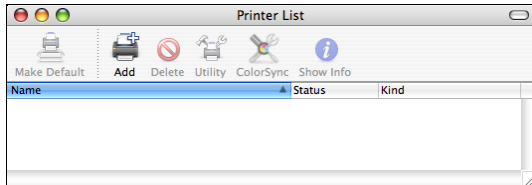

The detected printer appears in the **Printer Browser**.

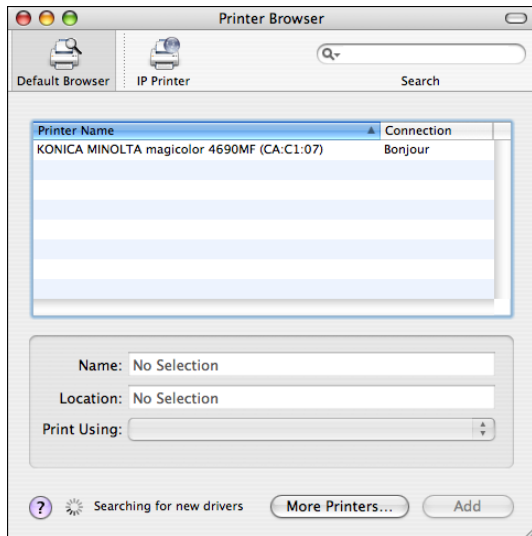

- 4 Select **KONICA MINOLTA magicolor 4690MF (xx:xx:xx)** in the **Printer Browser**.

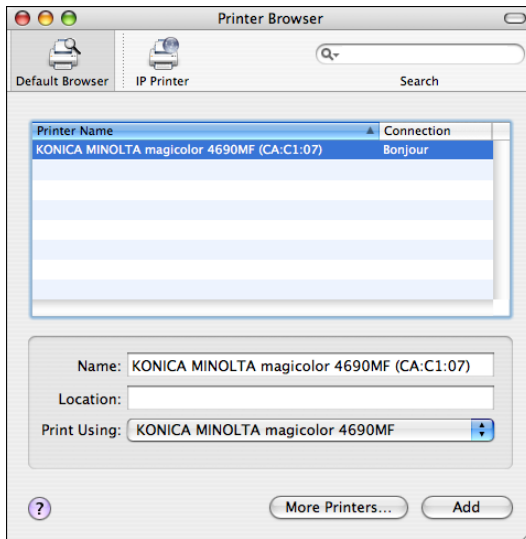

“xx:xx:xx” refers to the last six digits of the MAC address (in hexadecimal).

- 5 Check that **KONICA MINOLTA magicolor 4690MF** is selected in the **Print Using** list.
- 6 Click **Add**.

- 7 Select **Optional Trays** to match your printer setup, and then click **Continue**.

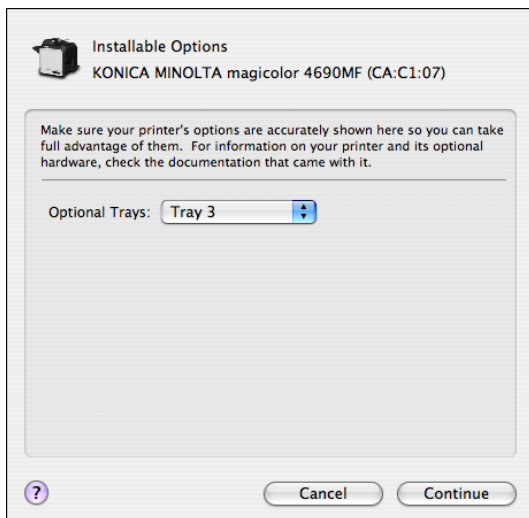

The new printer appears in the **Printer List** screen.

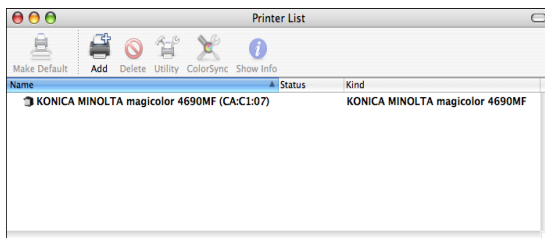

## IP Printing Setting

- 1 Connect the machine to an Ethernet network.
- 2 Open **Printer Setup Utility**, which can be accessed by clicking Startup Disk, then **Applications**, then **Utilities**.
- 3 Click **Add** in the **Printer List**.

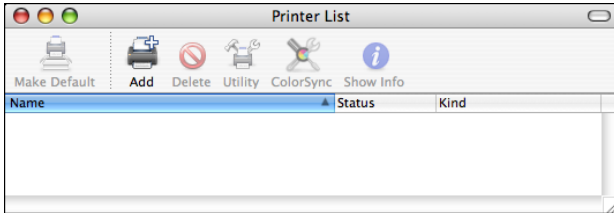

- 4 Click **IP Printer**.

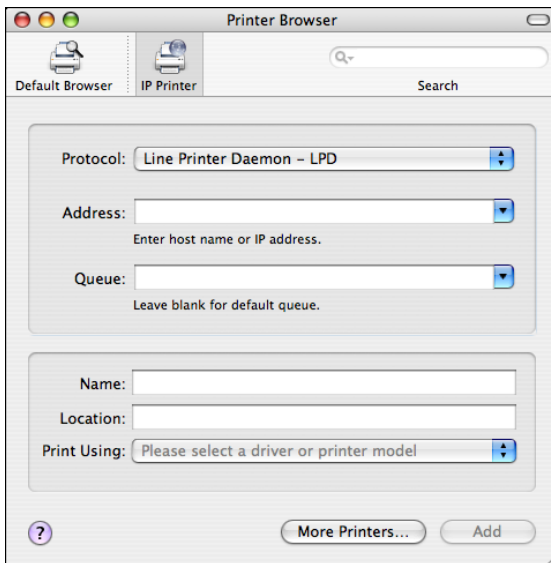

5 Select desired print protocol from the **Protocol** pop-up menu.

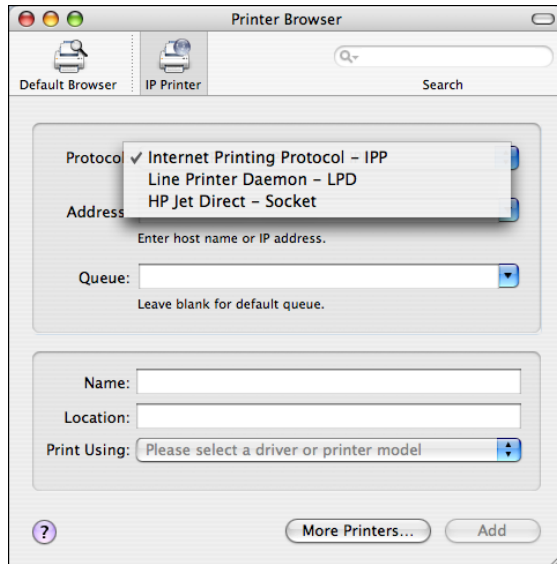

- For an IPP setup, select **Internet Printing Protocol - IPP**.
- For an LPD setup, select **Line Printer Daemon - LPD**.
- For a port 9100 setup, select **HP Jet Direct - Socket**.

- 6 Enter the IP address for the machine in the **Address** text box.

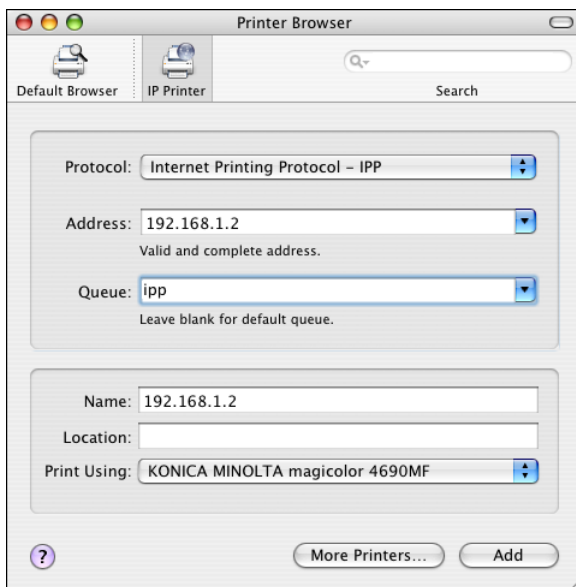

The screenshot shows the 'Printer Browser' window with the 'IP Printer' tab selected. The configuration fields are as follows:

- Protocol:** Internet Printing Protocol - IPP
- Address:** 192.168.1.2 (Valid and complete address.)
- Queue:** ipp (Leave blank for default queue.)
- Name:** 192.168.1.2
- Location:** (Empty)
- Print Using:** KONICA MINOLTA magicolor 4690MF

Buttons at the bottom include a help icon (?), 'More Printers...', and 'Add'.



- For an LPD setup, type "lp" in the **Queue** text box.
- For an IPP setup, type "ipp" in the **Queue** text box.

- 7 Select **KONICA MINOLTA magicolor 4690MF** in the **Print Using** list.
- 8 Click **Add**.

- 9 Select the **Optional Trays** to match your printer setup, and then click **Continue**.

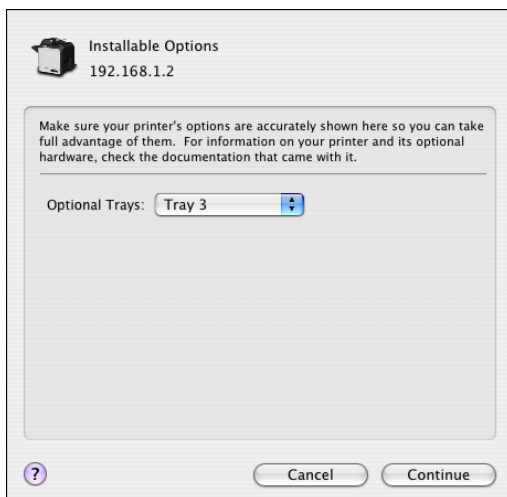

The new printer appears in the **Printer List** screen.

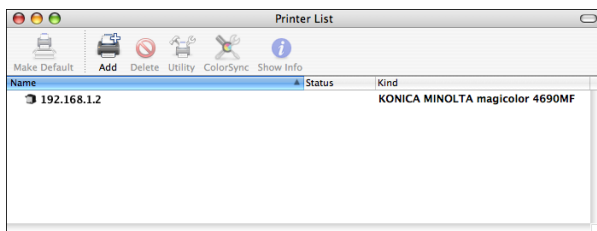

# Printer Settings (Mac OS X 10.5)



Before specifying the Printer settings, set *USB SETTING* (in the *UTILITY - ADMIN. MANAGEMENT* menu) to *Mac*. For details, refer to the *Printer/Copier/Scanner User's Guide on the Documentation CD/DVD*.

## When Using a USB Connection

- 1 Use a USB cable to connect the printer to your computer.
- 2 Select **System Preference** from the Apple menu.
- 3 Click **Print & Fax**.
- 4 In the **Print & Fax**, click + button.

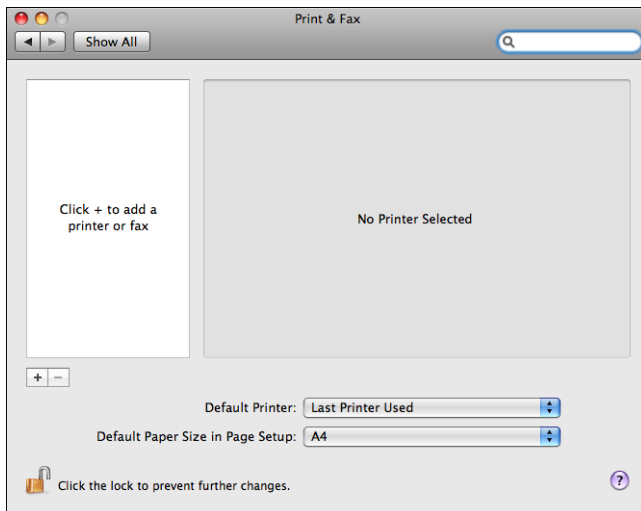

The detected printer appears in the Printer Browser.

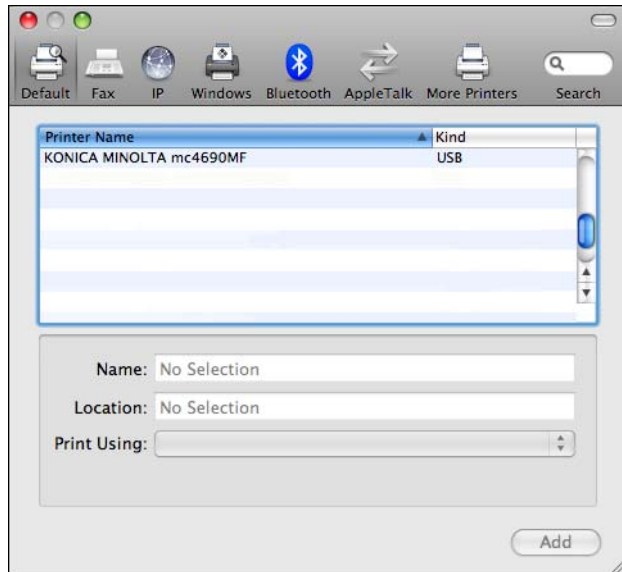

5 Select **KONICA MINOLTA mc4690MF** in the **Printer Name** list.

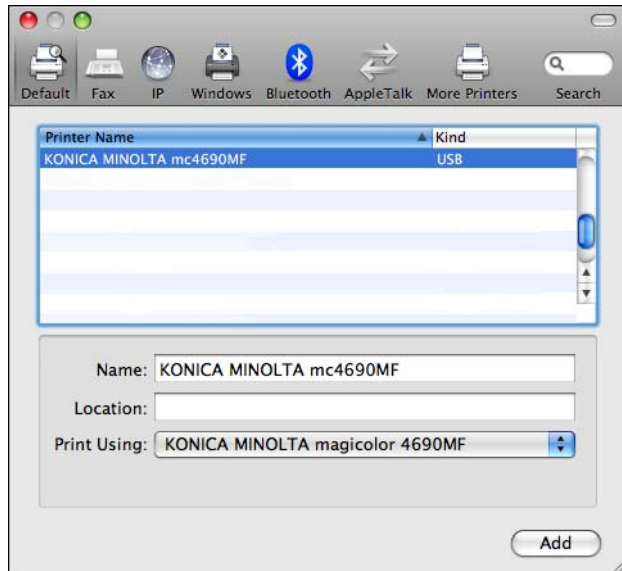



If **KONICA MINOLTA magicolor 4690MF** does not appear, check that the printer is turned on and the USB cable is connected, and then restart the computer.

- 6 Check that **KONICA MINOLTA magicolor 4690MF** is selected in the **Print Using** list.
- 7 Click **Add**.
- 8 Select **Optional Trays** to match your printer setup, and then click **Continue**.

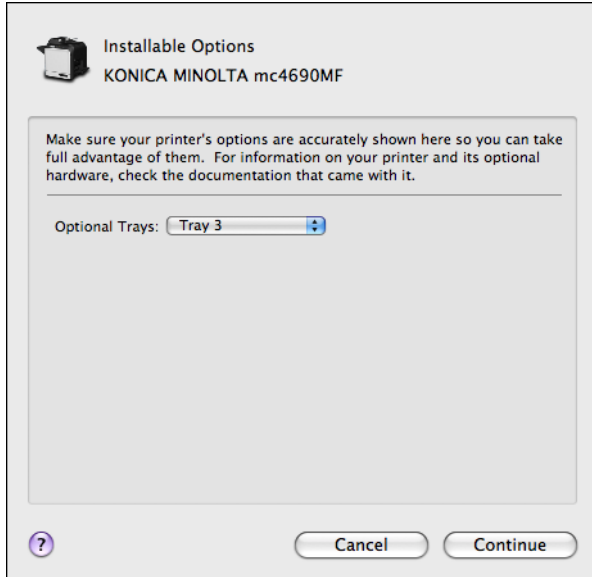

The new printer appears in the **Print & Fax** screen.

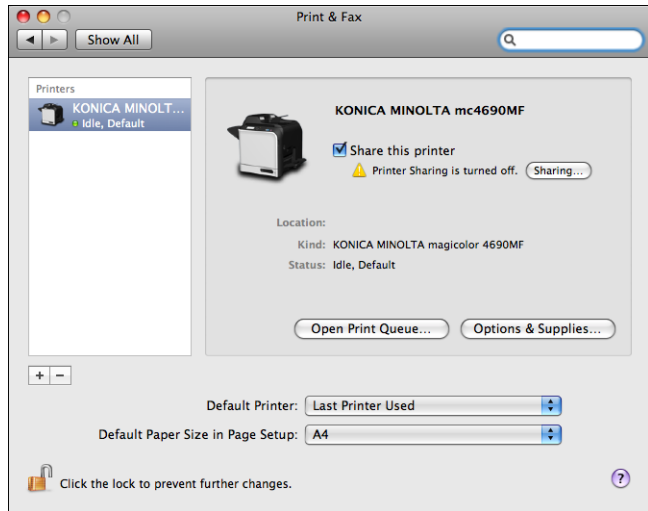

## When Using a Network Connection

The network connection settings can be specified in one of two ways: Bonjour Setting and IP printing setting (IPP, LPD or Socket).

### Bonjour Setting

- 1 Connect the printer to an Ethernet network.
- 2 Select **System Preference** from the Apple menu.
- 3 Click **Print & Fax**.
- 4 In the **Print & Fax**, click + button.

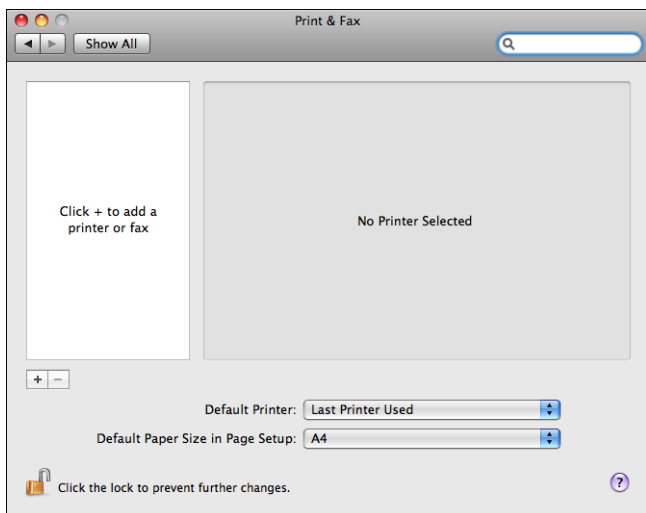

The detected printer appears in the Printer Browser.

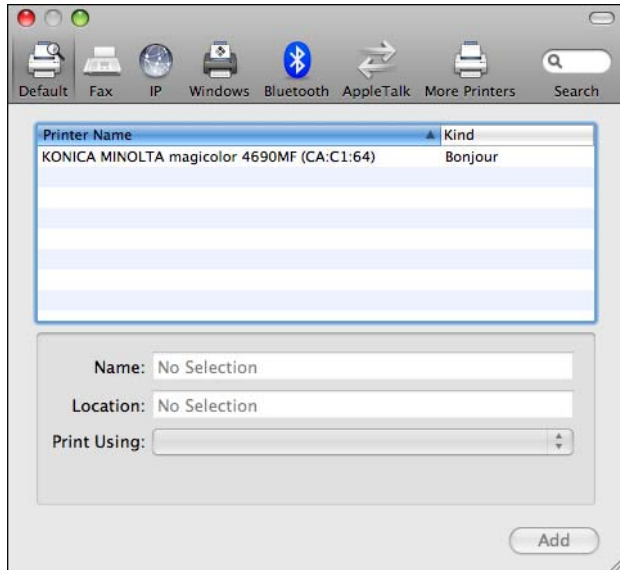

- 5 Select **KONICA MINOLTA magicolor 4690MF (xx:xx:xx)** in the **Printer Name** list.

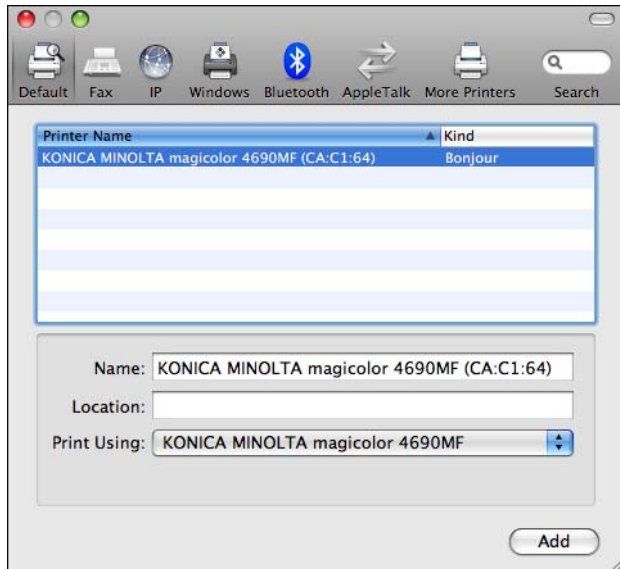

“xx:xx:xx” refers to the last six digits of the MAC address (in hexadecimal).

- 6 Check that **KONICA MINOLTA magicolor 4690MF** is selected in the **Print Using** list.
- 7 Click **Add**.
- 8 Select **Optional Trays** to match your printer setup, and then click **Continue**.

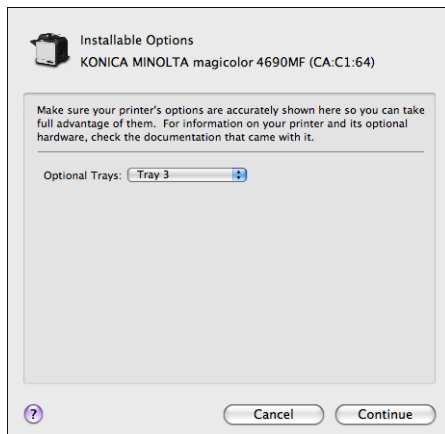

The new printer appears in the **Print & Fax** screen.

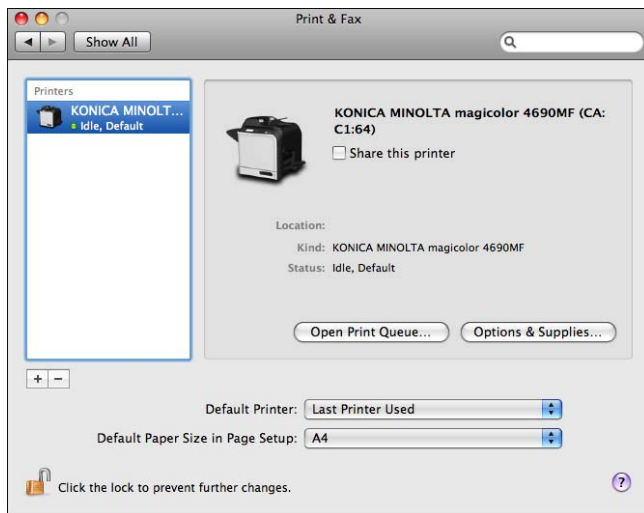

## IP Printing Setting

- 1 Connect the printer to an Ethernet network.
- 2 Select **System Preference** from the Apple menu.
- 3 Click **Print & Fax**.
- 4 In the **Print & Fax**, click + button.

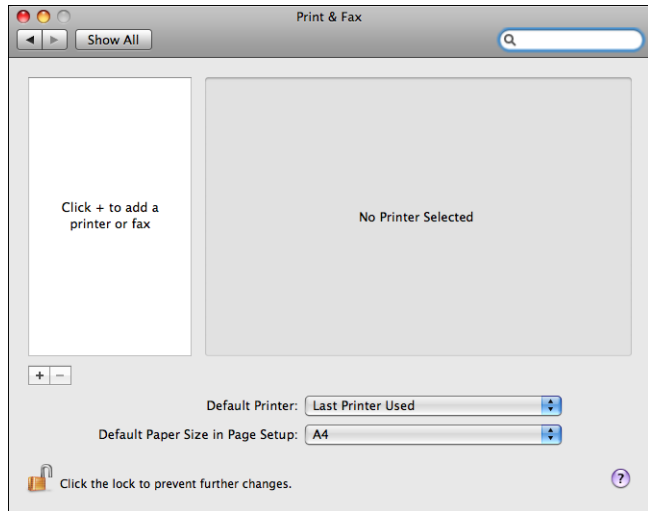

## 5 Click IP.

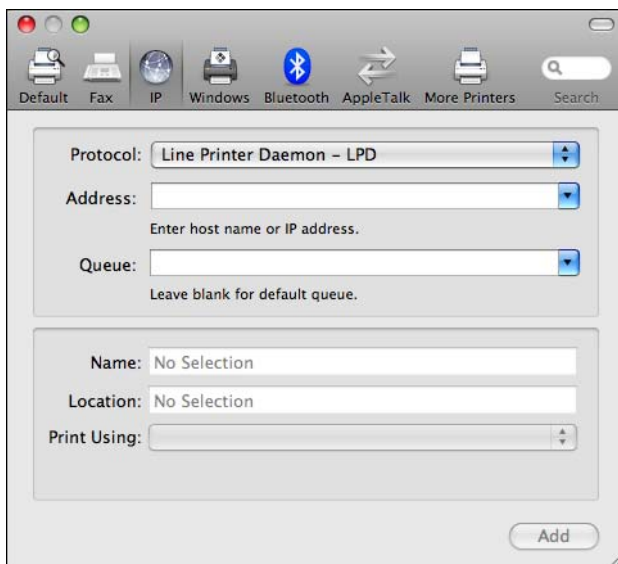

## 6 Select desired print protocol from the **Protocol** pop-up menu.

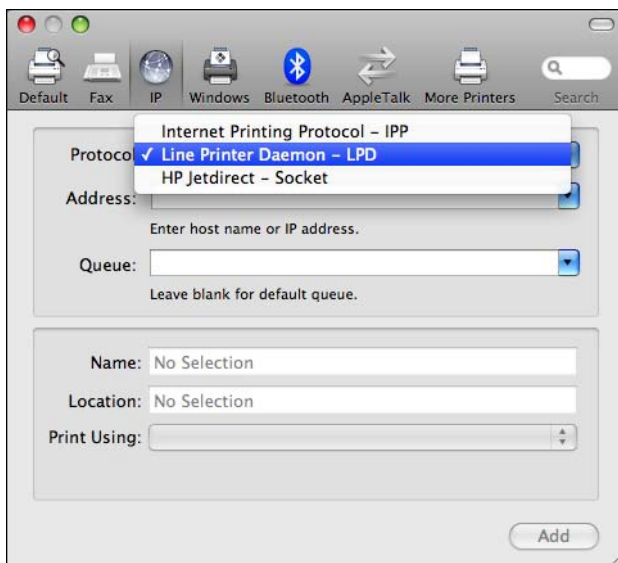

- For an IPP setup, select **Internet Printing Protocol - IPP**.
- For an LPD setup, select **Line Printer Daemon - LPD**.
- For a port 9100 setup, select **HP Jetdirect - Socket**.

- 7 Enter the IP address for the machine in the **Address** text box.

Default Fax IP Windows Bluetooth AppleTalk More Printers Search

Protocol: Line Printer Daemon - LPD

Address: 192.168.1.2  
Valid and complete address.

Queue: lp  
Leave blank for default queue.

Name: 192.168.1.2

Location:

Print Using: KONICA MINOLTA magicolor 4690MF

Add



- For an LPD setup, type "lp" in the **Queue** text box.
- For an IPP setup, type "ipp" in the **Queue** text box.

- 8 Check that **KONICA MINOLTA magicolor 4690MF** is selected in the **Print Using** list.
- 9 Click **Add**.

- 10 Select **Optional Trays** to match your printer setup, and then click **Continue**.

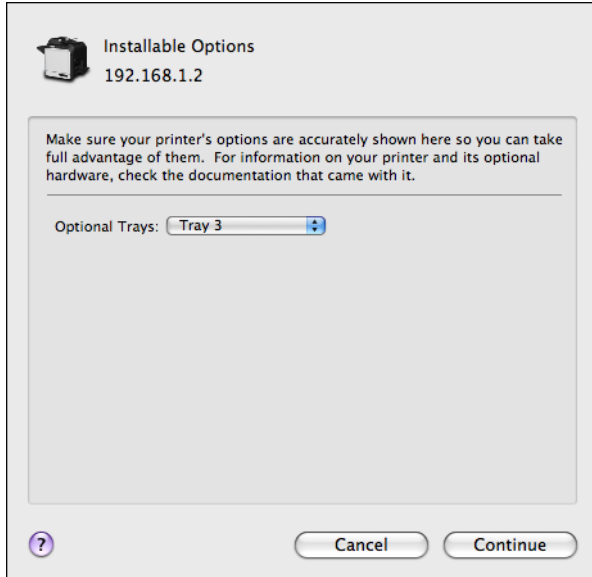

*The new printer appears in the **Print & Fax** screen.*

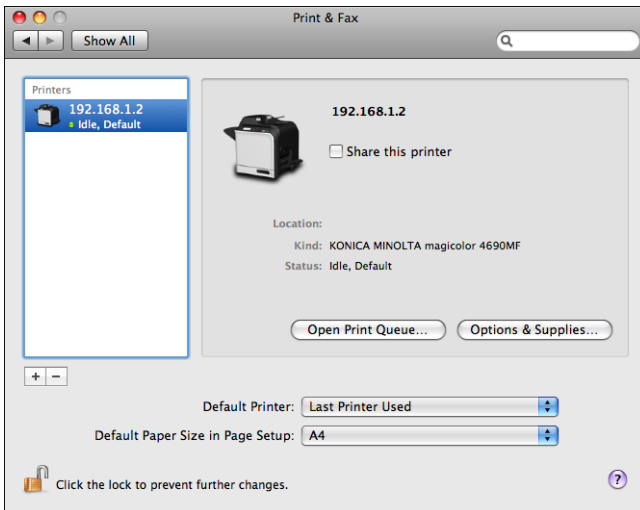

# Selecting Print Options

## For Mac OS X 10.2/10.3/10.4

- 1 Open **Printer Setup Utility (Print Center)**, which can be accessed by clicking Startup disk, then **Applications**, then **Utilities**.
- 2 Select this printer in the **Printer List**, and then select **Show Info** from the **Printers** menu.

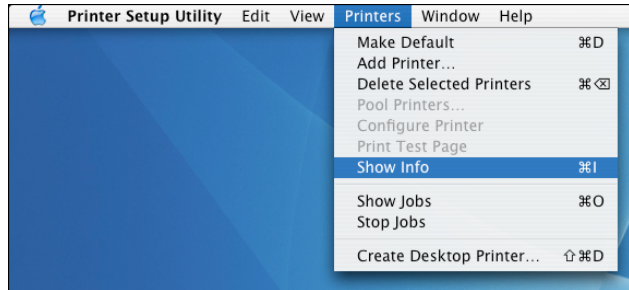

- 3 Select **Installable Options** from the pop-up menu.

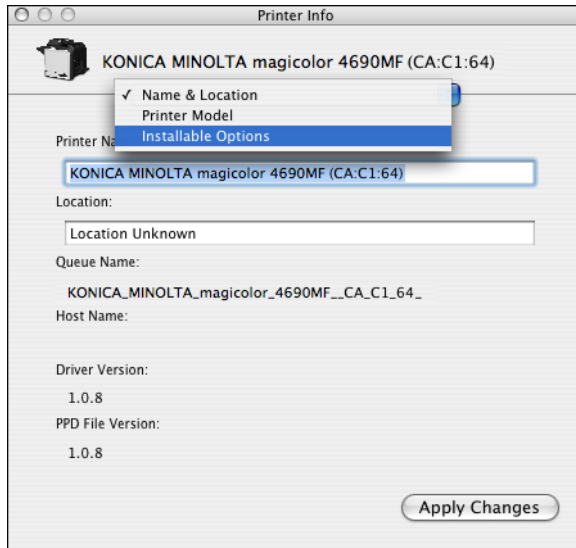

- 4 Select the **Optional Trays** to match your printer setup, and then click **Apply Changes**.

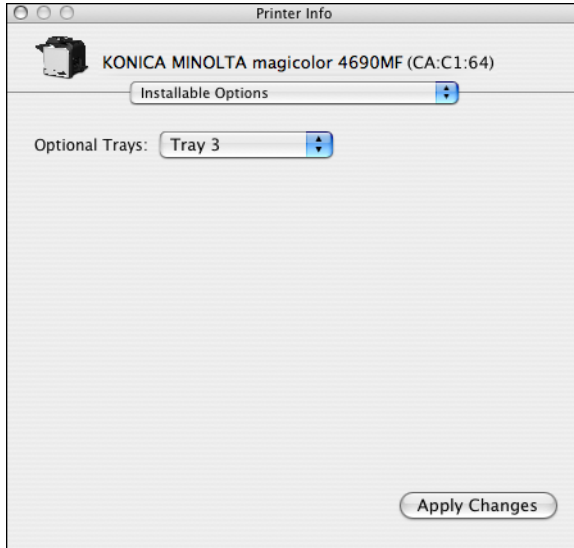

- 5 Close the **Printer Info** dialog box.

## For Mac OS X 10.5

- 1 Select **System Preference** from the Apple menu.
- 2 Click **Print & Fax**.
- 3 Select this printer in the **Printers List**, and then click **Options & Supplies**.

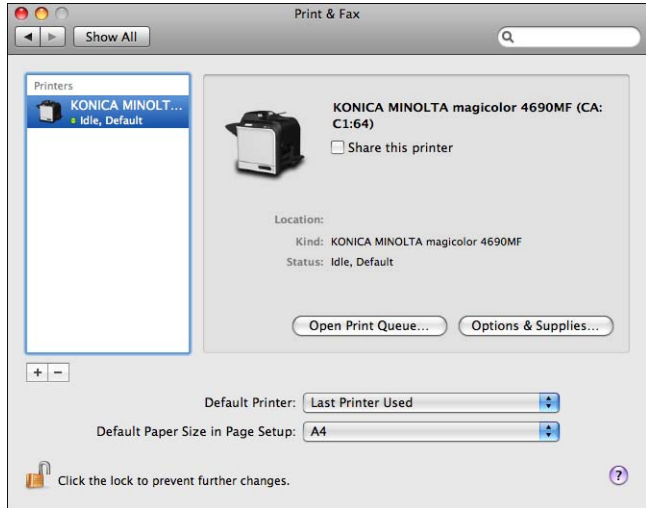

- 4 Select **Driver**.

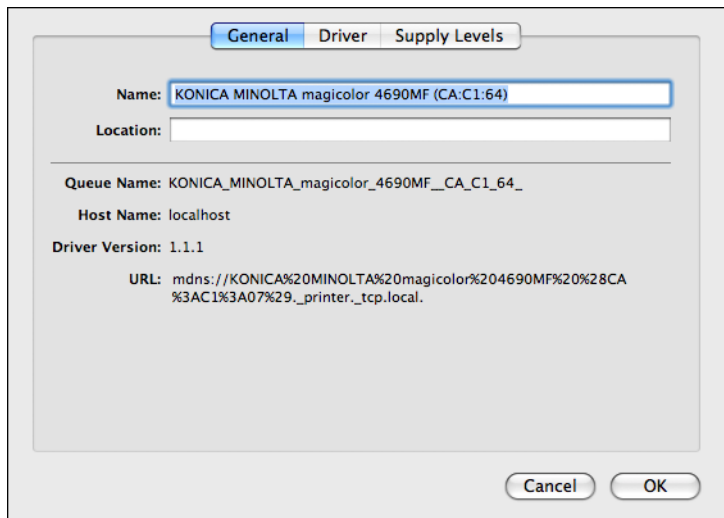

- 5 Select the **Optional Trays** to match your printer setup, and then click **OK**.

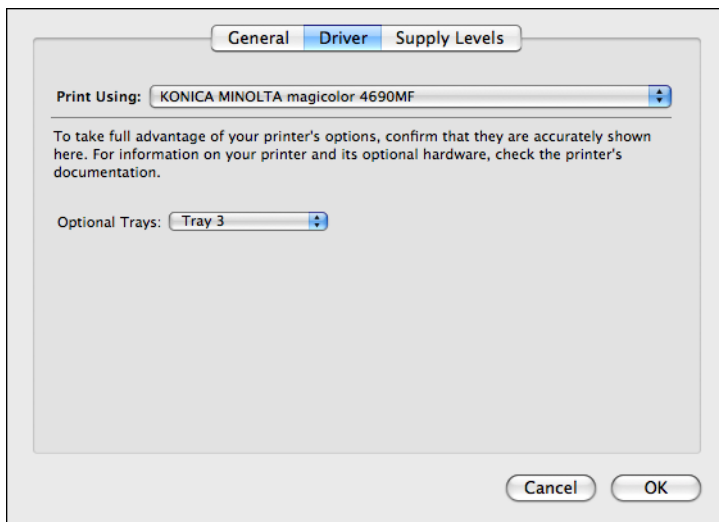

- 6 Close the **Print & Fax** screen.

# Uninstalling the Printer Driver

- 1 Insert the Drivers CD/DVD in the CD/DVD-ROM drive of your Macintosh.
- 2 Double-click the CD icon on the desktop, Mac folder, Printer Driver folder, and then double-click the **magicolor 4690MF Uninstaller**.



*The uninstaller for the printer driver starts up and the following message appears.*



- 3 Click **Remove**.

- 4 Enter the administrator user name and password in the Authenticate dialog box, and then click **OK**.

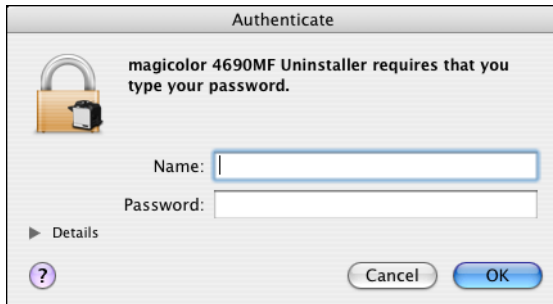

- 5 After the uninstallation has been completed, click **Close**.



*This completes the uninstallation of the printer driver.*

# Specifying Page Setup Settings

The following dialog box appears when **Page Setup...** is selected from the **File** menu in the application being used.

- 1 Select **Page Setup...** from the **File** menu.  
The **Page Setup** dialog box appears.
- 2 Select this printer in the **Format for** pop-up menu.

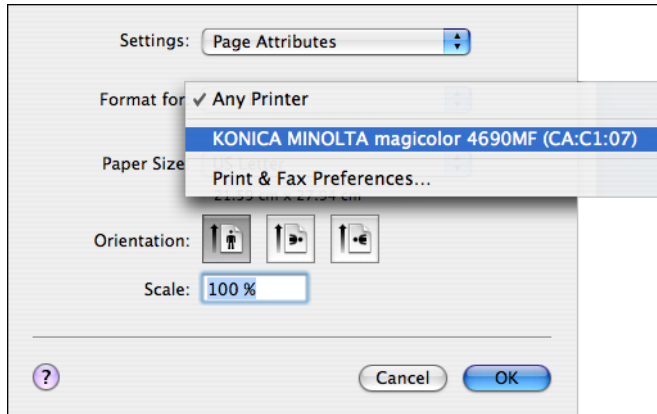

You can select the following sections from the **Settings** pop-up menu.

Section	Description
Page Attributes	This is used to specify the settings for the paper size, scaling, and print orientation.
Save As Default	This is used to save the new settings as the defaults.

## Page Attributes Options

The **Page Attributes** section is used to specify the settings for the paper size, scaling, and print orientation.

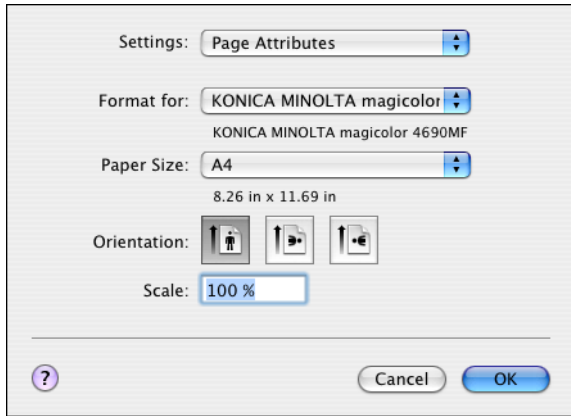

- **Paper Size**  
Select the desired paper size from the Paper Size pop-up menu.
- **Orientation**  
Select either a vertical or horizontal page orientation for printouts.
- **Scale**  
If you want to enlarge or reduce the size of the printout, enter the scale ratio here (25-400%).



*Regardless of which paper size is selected, the machine does not print within 0.157" (4 mm) of the edge of the paper.*

## Specifying Custom Paper Size

You can also specify a paper size that is not listed in the **Paper Size** pop-up menu.

- 1 Select **Manage Custom Sizes** from the pop-up menu, in the **Page Setup** dialog box.  
The **Custom Page Sizes** dialog box appears.

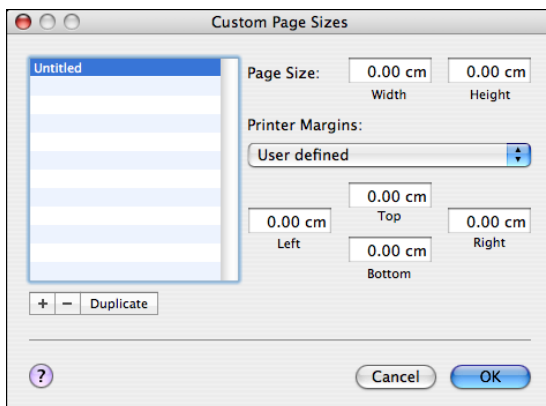

- +  
Click this button to create a new custom page size.
- -  
Click this button to delete a custom page size.
- Duplicate  
Click this button to duplicate (copy) the settings of an existing custom page size and create a new custom page size based on those settings.
- Page Size  
Enter the dimensions of the paper height and width for the custom page size.  
**Height:** 5.8 - 14.0" (148 - 356 mm)  
**Width:** 3.6 - 8.5" (92 - 216 mm)
- Printer Margins  
Enter the dimensions for the top, left, right, and bottom margins.

- 2 After you have finished entering the settings, click **OK**.



*Regardless of which paper is selected, the printer does not print within 0.157" (4 mm) of the edge of the paper.*

# Specifying Print Settings (Mac OS X 10.4)

The following dialog box appears when **Print...** is selected from the **File** menu in the application being used.

- 1 Select **Print...** from the **File** menu.  
The **Print** dialog box appears.
- 2 Select this printer in the **Printer** pop-up menu.  
The Print dialog box is used to specify the following print options.

## Print Dialog Box

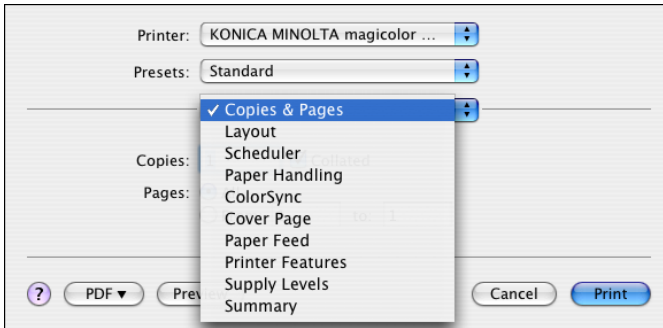

Section	Description
Copies & Pages	This section contains options for the number of copies to be printed and the range of pages to print.
Layout	This section contains options for specifying the page layout when printing and the setting for double-sided printing.
Scheduler	This section contains options for specifying the print timing and priority of jobs.
Paper Handling	This section contains options for specifying the pages to be printed and their printing order.
ColorSync	This section contains options for specifying ColorSync settings.
Cover Page	This section contains options for specifying cover page settings.
Paper Feed	This section contains paper feed options.

Section	Description
Printer Features	This section contains options for color printing and watermark settings.
Supply Levels	This section provides information for checking the amount of service life remaining on each consumable.
Summary	This is used to check the current settings.



*No warning message will be displayed if options cannot be used together are selected.*

## Common buttons

- ? (Help button)  
This displays help information about the Print dialog box.
- PDF  
Click this button to select the PDF menu. The print output can be saved as a PDF file or faxed.
- Preview  
Click this button to view a preview image of the printout, to check that the print options are set correctly.
- Cancel  
Click this button to close the Print dialog box without applying any of the settings.
- Print  
Click this button to print using the selected print options.

## Copies & Pages

The **Copies & Pages** section is used to specify the number of copies to print and the range of pages to print.

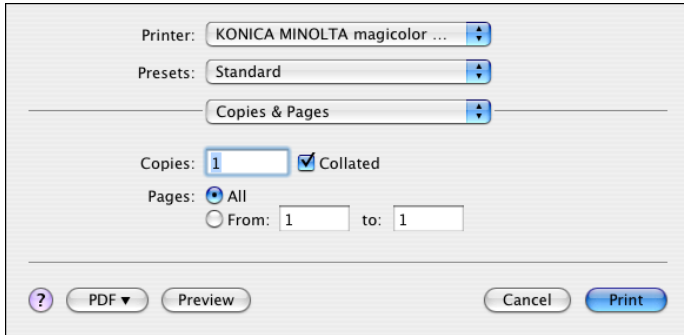

### ■ Copies

This specifies the number of copies to be printed. If the **Collated** checkbox is selected, all pages in the documents are printed as sets of print-outs.

For example, if 5 is entered for **Copies** and **Collated** is selected, the document is printed five times from the first page to the last page.

### ■ Pages

**All:** Prints all pages in the document.

**From, to:** Specifies the range of pages to be printed.

## Layout

The **Layout** section is used to specify the page layout when printing and the setting for double-sided printing.

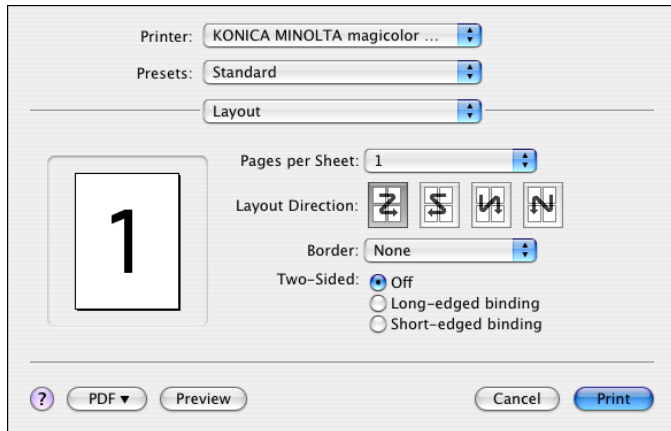

- **Pages per Sheet**  
Specifies the number of pages to be printed on one sheet of paper. For example, if **2** is selected, two pages are printed on one sheet of paper.
- **Layout Direction**  
If you are printing more than one page per sheet, this specifies the direction and order the pages should be arranged on each sheet of paper.
- **Border**  
This prints a border around the image for each of the pages printed on one sheet of paper when more than one page is printed on one sheet of paper.
- **Two-Sided**  
Select the desired setting for double-sided printing.
  - Off:** Double-sided printing is not performed.
  - Long-edged binding:** Double-sided printing is performed with the binding along the long edge of the paper.
  - Short-edged binding:** Double-sided printing is performed with the binding along the short edge of the paper.

# Scheduler

The **Scheduler** section is used to specify the timing and priority for printing jobs.

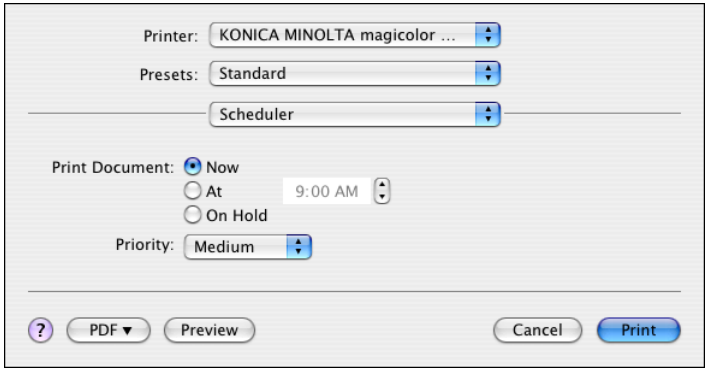

- **Print Document**

- Now:** Select this option to begin printing immediately.

- At:** Specify the time to begin printing.

- On Hold:** Select this option to hold the print job.

- **Priority**

- Select the priority for printing jobs that are being held.

## Paper Handling

The **Paper Handling** section is used to specify the pages that are to be printed and the order in which the pages are printed.

Printer: KONICA MINOLTA magicolor ...

Presets: Standard

Paper Handling

Page Order:  Automatic  
 Normal  
 Reverse

Print:  All Pages  
 Odd numbered pages  
 Even numbered pages

Destination Paper Size:

Use documents paper size: A4  
 Scale to fit paper size: A4  
 Scale down only

? PDF Preview Cancel Print

### ■ Page Order

**Automatic:** Select this option to print in the original page order of the document.

**Normal:** Select this option to print in the normal page order.

**Reverse:** Select this option to print in the reverse page order.

### ■ Print

**All Pages:** Select this option to print all pages.

**Odd numbered pages:** Select this option to print only the pages with odd page numbers.

**Even numbered pages:** Select this option to print only the pages with even page numbers.

### ■ Destination Paper Size

**Use documents paper size:** Select this option to use the document size as created by software applications.

**Scale to fit paper size:** Select this option to fit the document size to the size of paper used by the machine. Specify the size of paper used by the machine.

## ColorSync

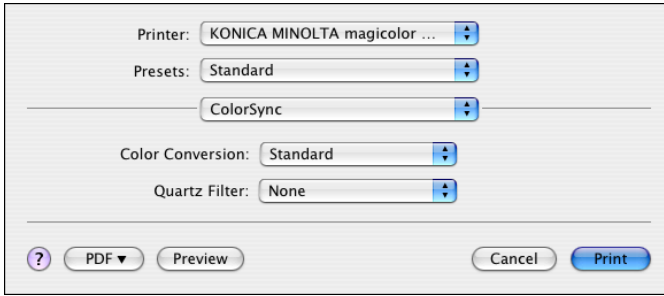

- **Color Conversion**  
Allows you to select host-based color matching or printer-based color matching.
- **Quartz Filter**  
Allows you to select Quartz Filter.

## Cover Page

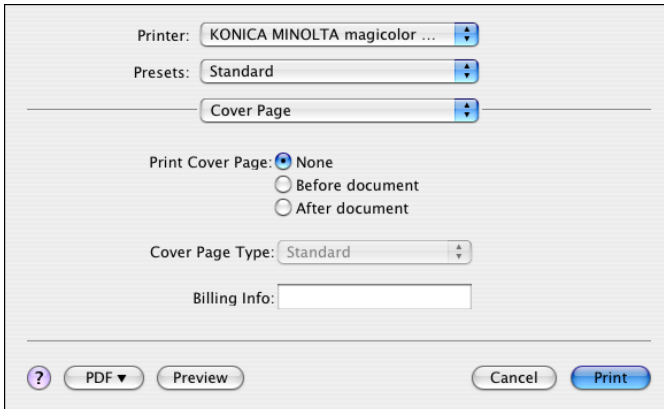

- **Print Cover Page**  
Allows you to set cover page before or after document.
- **Cover Page Type**  
Allows you to select cover page type.
- **Billing Info**  
Allows you to set billing information printed on cover page.

## Paper Feed

The **Paper Feed** section is used to specify the paper feed setting.

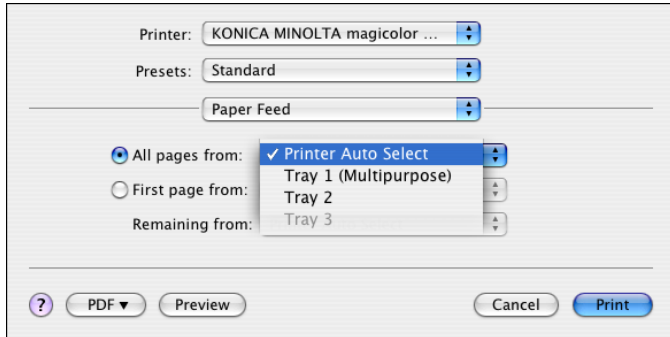

- **All pages from**  
All pages in the document are printed using the paper in the specified paper tray.
- **First page from**  
The first page of the document is printed on paper from a paper tray different from the tray used to print the rest of the document.
- **Remaining from**  
The rest of the document is printed from the specified paper tray when the first page is to be printed on paper from a different tray.



*If an optional lower feeder unit is installed, select **Tray 3** under **Installable Options** (p. 33). If **Tray 3** is not selected, **Tray 3** appear in gray and cannot be selected.*

## Printer Features

The **Printer Features** section is used to specify the resolution, paper type, color options, watermark options etc., for the **Basic Features**, **Color Matching Options**, **Image Options**, **Watermark Selection**, **Watermark Orientation**, and **Watermark Setting** feature sets.

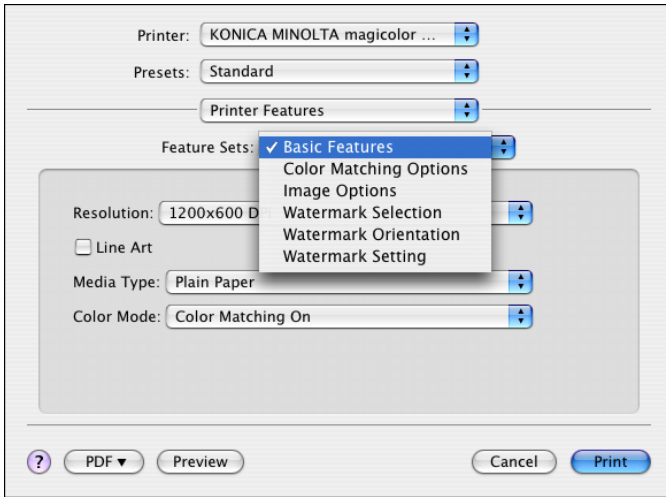

## Basic Features



- **Resolution**  
This option specifies the resolution to be used when printing a document.
- **Line Art**  
Select this check box to print more detailed images.
- **Media Type**  
This option specifies the type of paper on which the print image will be printed.
- **Color Mode**  
This option specifies whether the document should be printed in color (Color Matching On / Color Matching Off) or grayscale.

## Color Matching Options

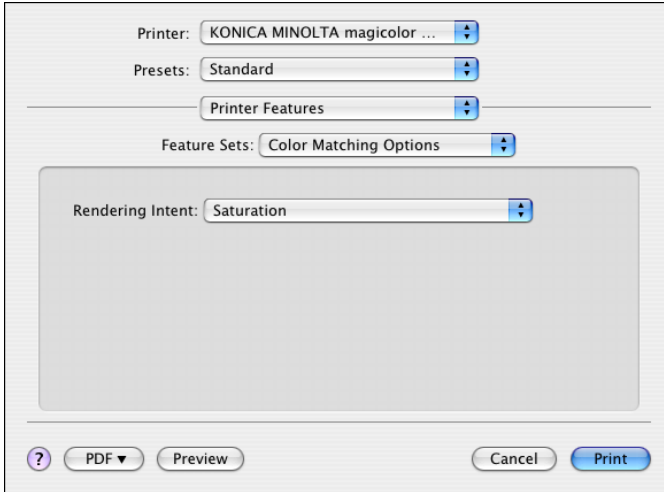

### ■ Rendering Intent

This option specifies the color matching settings.

**Perceptual:** Performs suitable color matching for photographic images.

**Colorimetric:** Performs most accurate hue color match, but the printer may replace hues it cannot reproduce.

**Saturation:** Performs suitable color matching for business graphics.

## Image Options

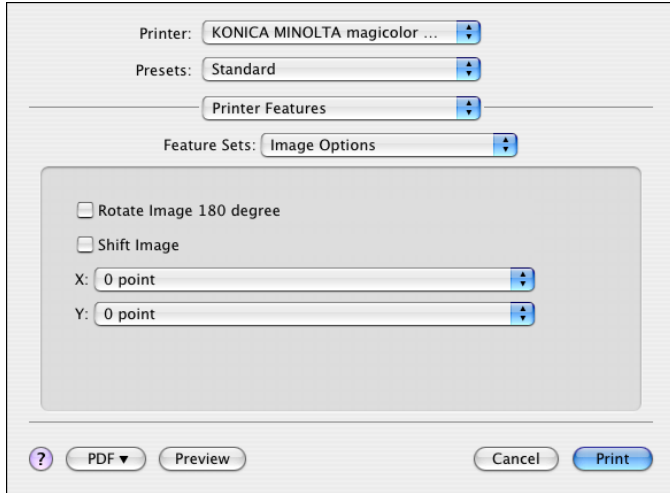

- **Rotate Image 180 degree**  
Select this check box to print the image rotated 180 degrees.
- **Shift Image**  
Select this check box to print the image shifted in the X and Y directions.  
**X:** Select the distance to shift the image in the X direction.  
**Y:** Select the distance to shift the image in the Y direction.

## Watermark Selection

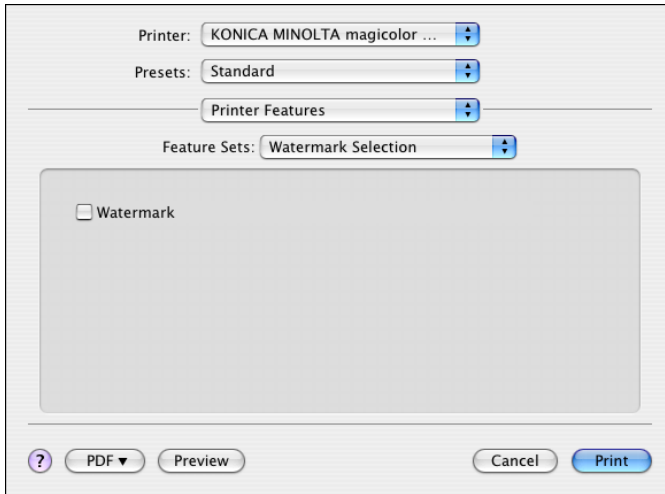

- **Watermark**  
This specifies whether to use a watermark print.

## Watermark Orientation

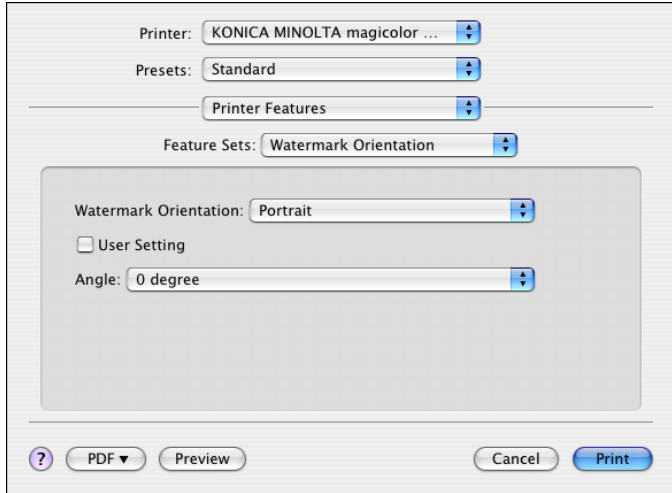

- **Watermark Orientation**  
This option specifies the direction of the text in a watermark.
- **User Setting**  
Select this check box to select the angle of the watermark.
- **Angle**  
Select the angle of the watermark.

## Watermark Setting

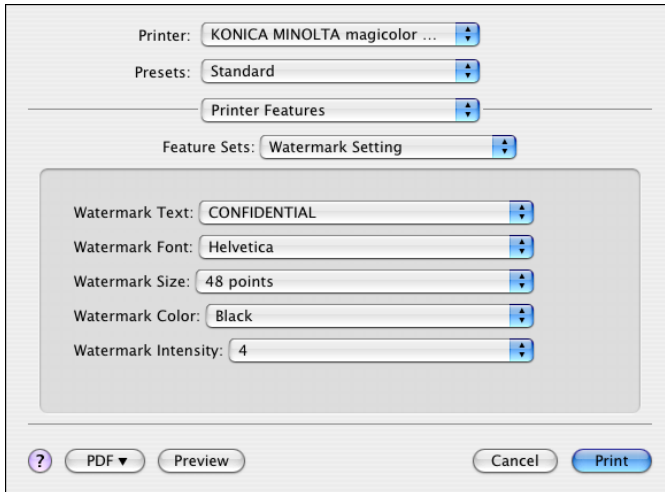

- **Watermark Text**  
This specifies the text in the watermark.
- **Watermark Font**  
This specifies the font to be used for the text in the watermark.
- **Watermark Size**  
This specifies the font size to be used for the text in the watermark.
- **Watermark Color**  
This specifies the color of the text in the watermark.
- **Watermark Intensity**  
This specifies the density of text in the watermark.

## Supply Levels

The **Supply Levels** section provides information for checking the amount of service life remaining on each consumable.

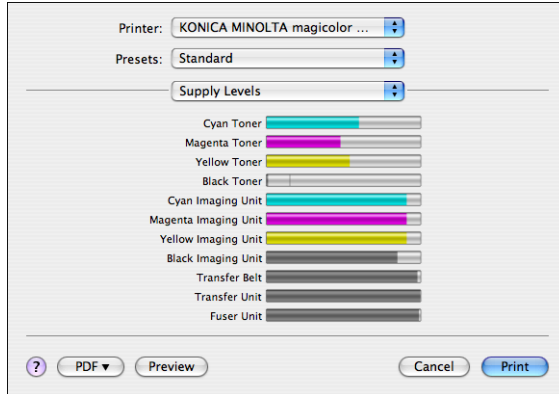

The **Supply Levels** section appears when a printer is created on Mac OS X v10.4 with a Bonjour, IPP, LPD, Socket connection.



The **Supply Levels** section may not appear depending on the application you use.

## Summary

The **Summary** is used to check the currently selected print settings.

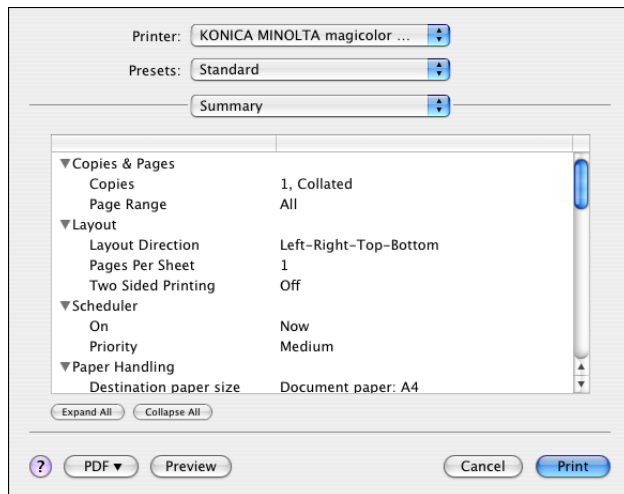

## Using Additional Features (Mac OS X 10.3)

The following dialog box appears when **Print...** is selected from the **File** menu in the application being used.

- 1 Select **Print...** from the **File** menu.  
The **Print** dialog box appears.
- 2 From the **PDF** pop-up, select **KONICA MINOLTA**, and then select the feature to be used.

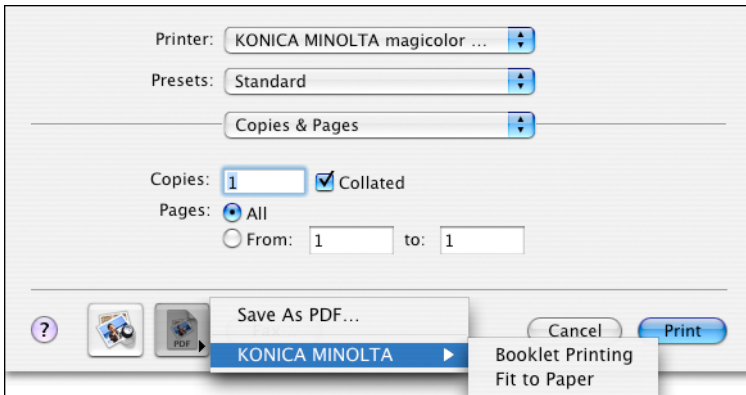

- **Booklet Printing**  
Print the document as a booklet. The binding can be set to the left or right side.
  - **Fit to Paper**  
Print with the paper size of the document adjusted to any paper size.
-  *When printing with the **Fit to Paper** feature, the image is printed centered in the paper.*
- 3 Specify the necessary settings, and then click **Print**.

## Booklet Printing

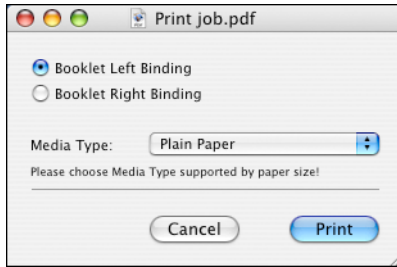

- **Booklet Left Binding**  
Select to bind the document on the left side.
- **Booklet Right Binding**  
Select to bind the document on the right side.
- **Media Type**  
Select the type of paper to be printed.



*Select a paper type that is compatible with the paper size being used.*

- **Cancel**  
Stops printing.
- **Print**  
Prints the document bound at the specified location.

## Fit to Paper

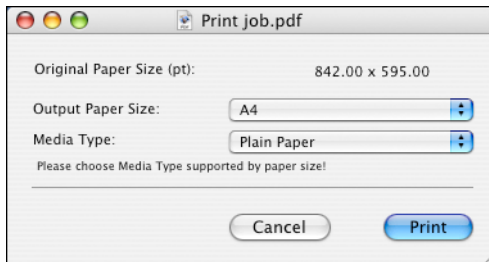

- **Original Paper Size (pt)**  
The size of the original document (in points) is displayed.
- **Output Paper Size**  
Select the size of paper to be printed.
- **Media Type**  
Select the type of paper to be printed.



*Select a paper type that is compatible with the paper size being used.*

- **Cancel**  
Stops printing.
- **Print**  
The document is printed automatically reduced or enlarged to fit the selected paper size.

# Specifying Print Settings (Mac OS X 10.5)

The following dialog box appears when **Print...** is selected from the **File** menu in the application being used.

1 Select **Print...** from the **File** menu.

*The **Print** dialog box appears.*

2 Select this printer in the **Printer** pop-up menu.

*The **Print** dialog box is used to specify the following print options.*

## Print Dialog Box

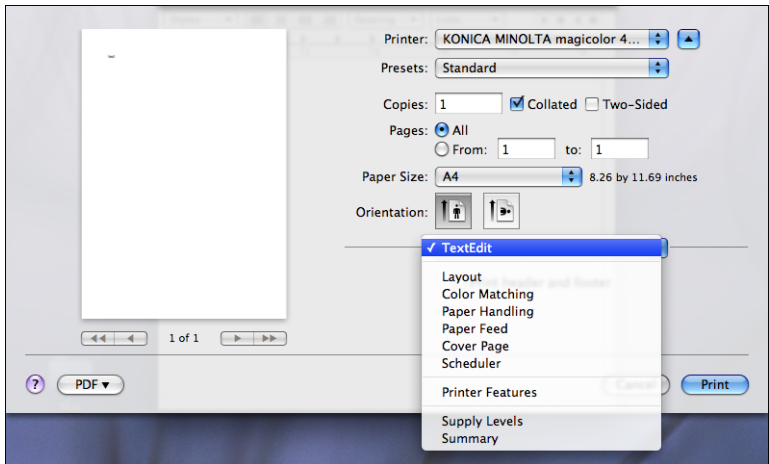

Section	Description
Layout	This section contains options for specifying the page layout when printing and the setting for double-sided printing.
Color Matching	This section contains options for specifying ColorSync settings.
Paper Handling	This section contains options for specifying the pages to be printed and their printing order.
Paper Feed	This section contains paper feed options.
Cover Page	This section contains options for specifying cover page settings.
Scheduler	This section contains options for specifying the print timing and priority of jobs.

Section	Description
Printer Features	This section contains options for color printing and watermark settings.
Supply Levels	This section provides information for checking the amount of service life remaining on each consumable.
Summary	This is used to check the current settings.



*No warning message will be displayed if options cannot be used together are selected.*

## Common buttons

- ? (Help button)  
This displays help information about the Print dialog box.
- PDF  
Click this button to select the PDF menu. The print output can be saved as a PDF file or faxed.
- Cancel  
Click this button to close the Print dialog box without applying any of the settings.
- Print  
Click this button to print using the selected print options.
- Copies  
This specifies the number of copies to be printed. If the **Collated** checkbox is selected, all pages in the documents are printed as sets of printouts. For example, if 5 is entered for **Copies** and **Collated** is selected, the document is printed five times from the first page to the last page. If Two-Sided checkbox is selected, the document is printed on both sides of the paper.
- Pages  
**All:** Prints all pages in the document.  
**From, to:** Specifies the range of pages to be printed.
- Paper Size  
Select the desired paper size from the Paper Size pop-up menu.
- Orientation  
Select either a vertical or horizontal page orientation for printouts.

## Layout

The **Layout** section is used to specify the page layout when printing and the setting for double-sided printing.

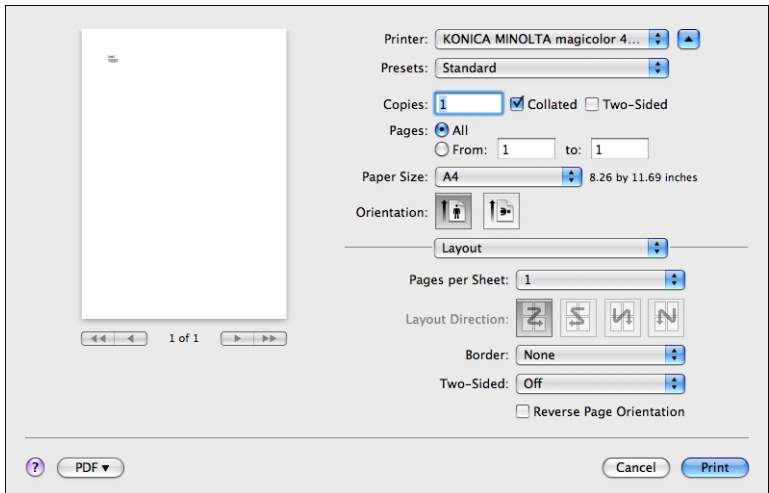

- **Pages per Sheet**  
Specifies the number of pages to be printed on one sheet of paper. For example, if **2** is selected, two pages are printed on one sheet of paper.
- **Layout Direction**  
If you are printing more than one page per sheet, this specifies the direction and order the pages should be arranged on each sheet of paper.
- **Border**  
This prints a border around the image for each of the pages printed on one sheet of paper when more than one page is printed on one sheet of paper.
- **Two-Sided**  
Select the desired setting for double-sided printing.
  - Off:** Double-sided printing is not performed.
  - Long-edged binding:** Double-sided printing is performed with the binding along the long edge of the paper.
  - Short-edged binding:** Double-sided printing is performed with the binding along the short edge of the paper.
- **Reverse Page Orientation**  
The printing direction is inverted vertically.

# Color Matching

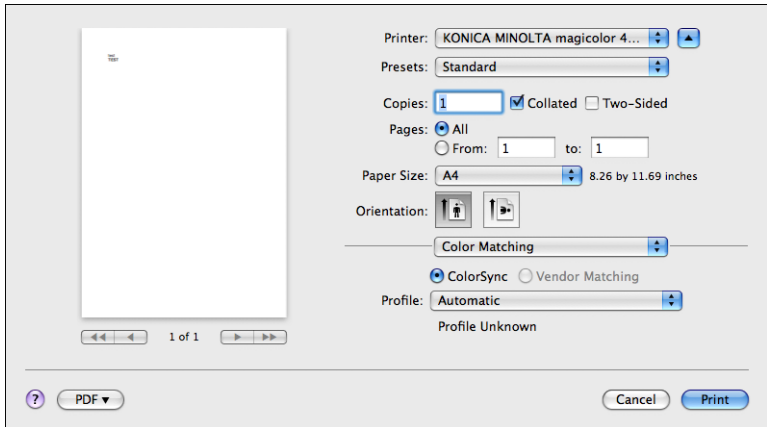

- Color Matching
  - ColorSync: Allows you to select host-based color matching.
  - Vendor Matching: Allows you to select printer-based color matching.
- Profile
  - Allows you to select ColorSync Profile.

## Paper Handling

The **Paper Handling** section is used to specify the pages that are to be printed and the order in which the pages are printed.

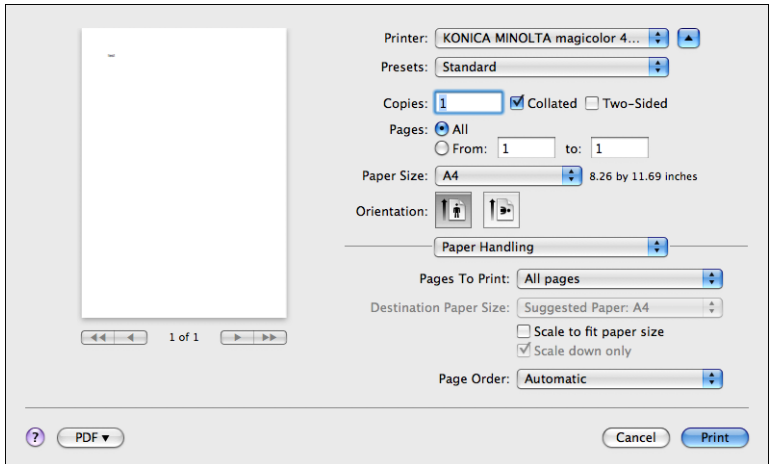

### ■ Pages To Print

**All pages:** Select this option to print all pages.

**Odd Only:** Select this option to print only the pages with odd page numbers.

**Even Only:** Select this option to print only the pages with even page numbers.

### ■ Destination Paper Size

Select this option to use the document size as created by software applications.

**Scale to fit paper size:** Select this option to fit the document size to the size of paper used by the printer.

Specify the size of paper used by the printer.

**Scale down only:** Select this option to reduce the printing size.

### ■ Page Order

**Automatic:** Select this option to print in the original page order of the document.

**Normal:** Select this option to print in the normal page order.

**Reverse:** Select this option to print in the reverse page order.

# Paper Feed

The **Paper Feed** section is used to specify the paper feed setting.

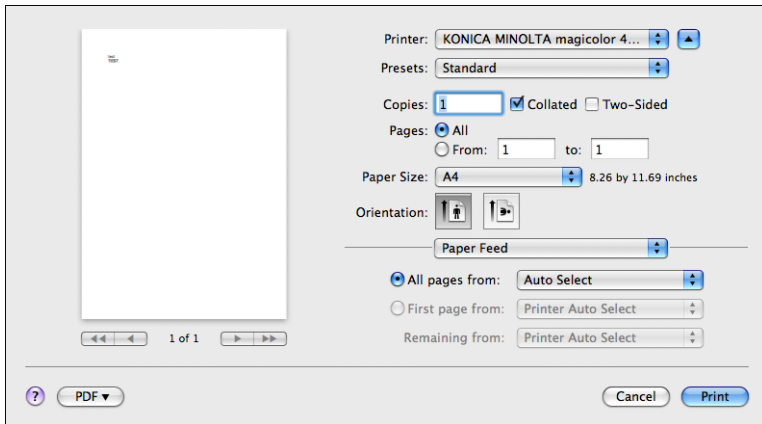

- All pages from  
All pages in the document are printed using the paper in the specified paper tray.
- First page from  
The first page of the document is printed on paper from a paper tray different from the tray used to print the rest of the document.
- Remaining from  
The rest of the document is printed from the specified paper tray when the first page is to be printed on paper from a different tray.



*If an optional lower feeder unit is installed, select **Tray 3** under **Installable Options** (p. 33). If **Tray 3** is not selected, **Tray 3** appear in gray and cannot be selected.*

## Cover Page

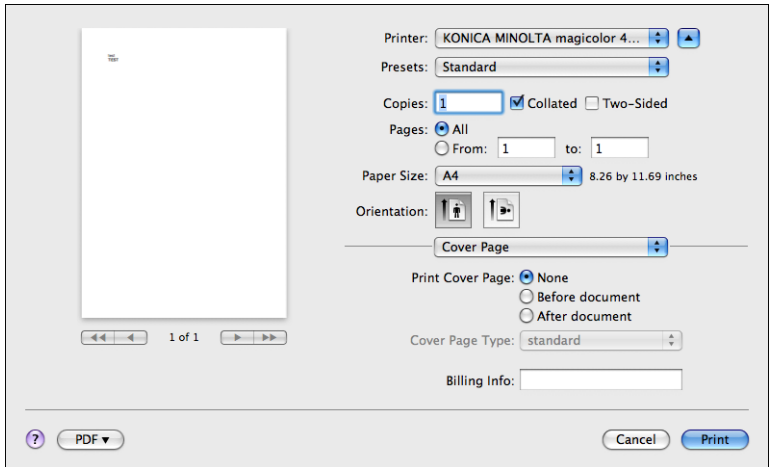

- **Print Cover Page**  
Allows you to set cover page before or after document.
- **Cover Page Type**  
Allows you to select cover page type.
- **Billing Info**  
Allows you to set billing information printed on cover page.

# Scheduler

The **Scheduler** section is used to specify the timing and priority for printing jobs.

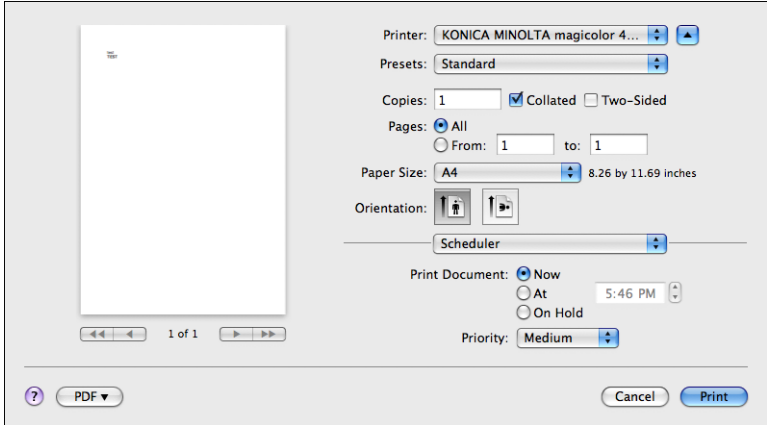

- **Print Document**

**Now:** Select this option to begin printing immediately.

**At:** Specify the time to begin printing.

**On Hold:** Select this option to hold the print job.

- **Priority**

Select the priority for printing jobs that are being held.

## Printer Features

The **Printer Features** section is used to specify the resolution, paper type, color options, watermark options etc., for the **Basic Features**, **Color Matching Options**, **Image Options**, **Watermark Selection**, **Watermark Orientation**, and **Watermark Setting** feature sets.

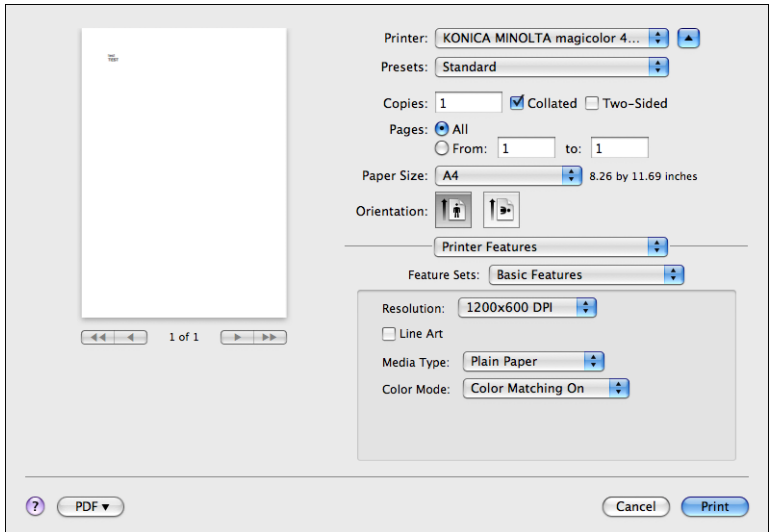

### Basic Features

- **Resolution**  
This Option specifies the resolution to be used when printing a document.
- **Line Art**  
Select this check box to print more detailed images.
- **Media Type**  
This option specifies the type of paper on which the print image will be printed.
- **Color Mode**  
This option specifies whether the document should be printed in color (Color Matching On / Color Matching Off) or grayscale.

## Color Matching Option

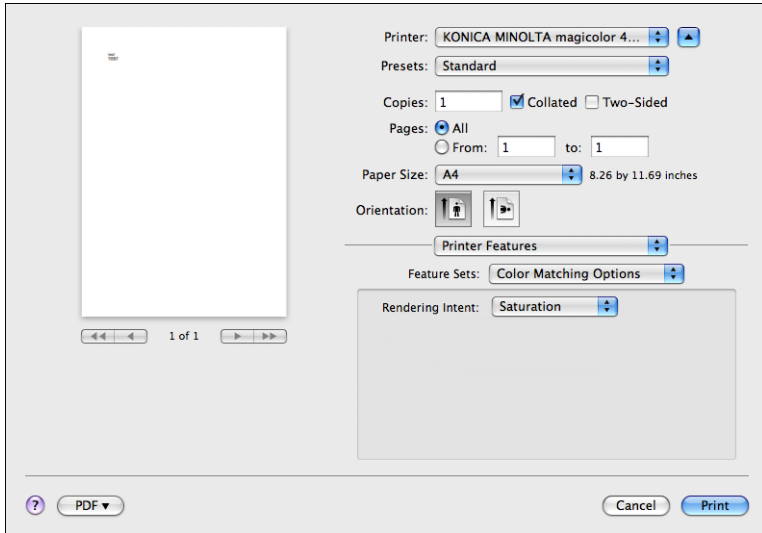

### ■ Rendering Intent

This option specifies the color matching settings.

**Perceptual:** Performs suitable color matching for photographic images.

**Colorimetric:** Performs most accurate hue color match, but the printer may replace hues it cannot reproduce.

**Saturation:** Performs suitable color matching for business graphics.

## Image Options

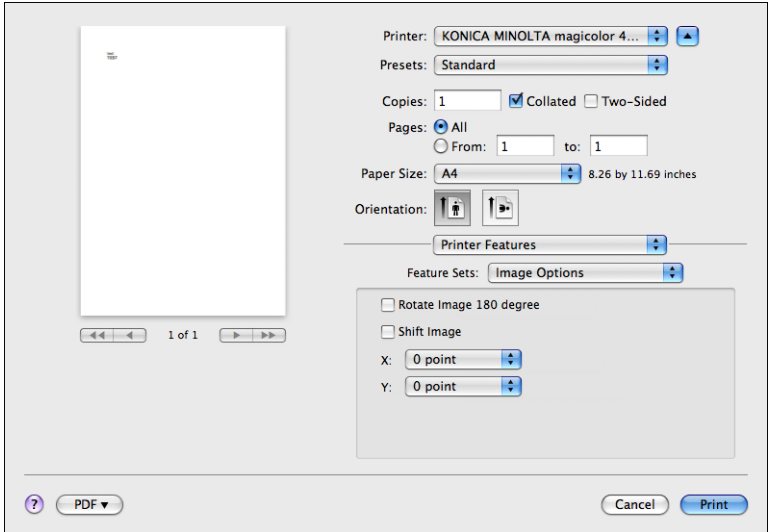

- **Rotate Image 180 degree**  
Select this check box to print the image rotated 180 degrees.
- **Shift Image**  
Select this check box to print the image shifted in the X and Y directions.  
**X:** Select the distance to shift the image in the X direction.  
**Y:** Select the distance to shift the image in the Y direction.

## Watermark Selection

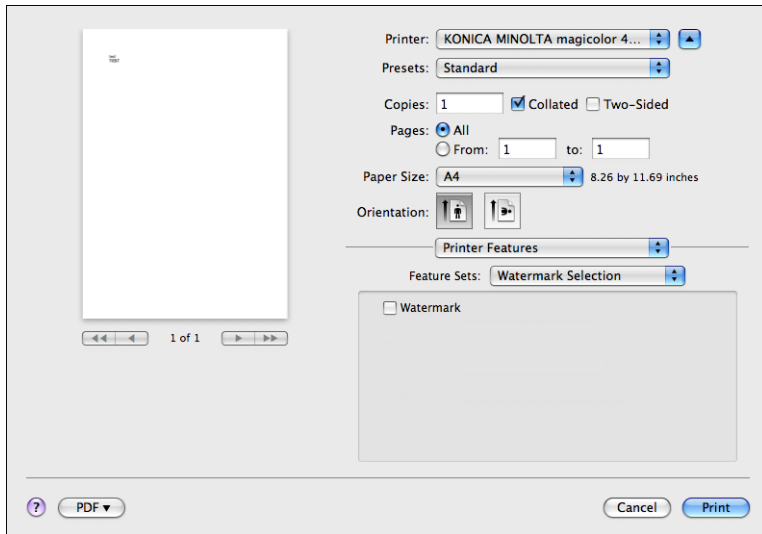

### ■ Watermark

This specifies whether to use a watermark print.

## Watermark Orientation

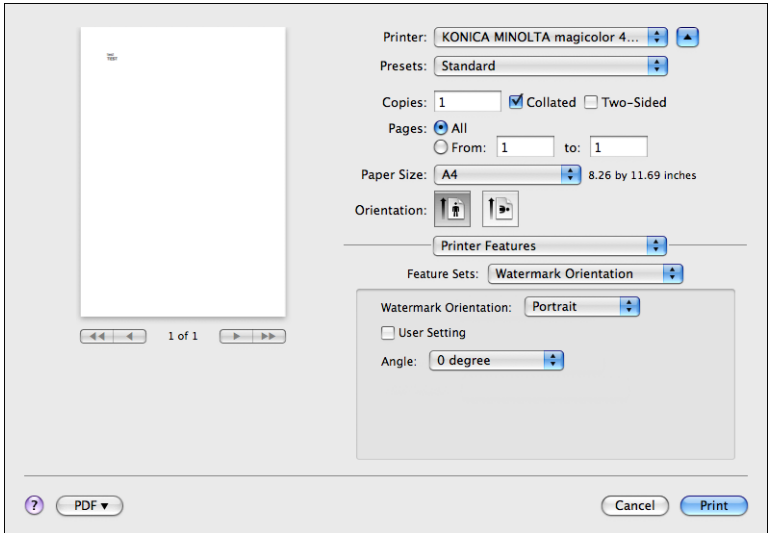

- **Watermark Orientation**  
This option specifies the direction of the text in a watermark.
- **User Setting**  
Select this check box to select the angle of the watermark.
- **Angle**  
Select the angle of the watermark.

## Watermark Setting

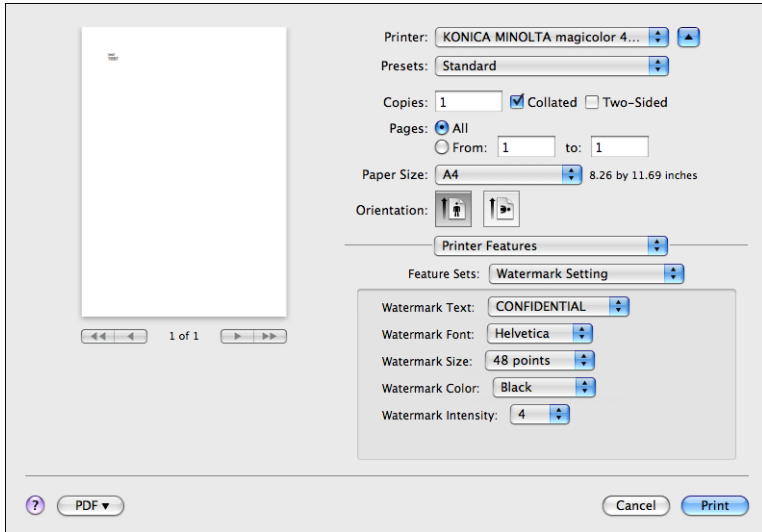

- **Watermark Text**  
This specifies the text in the watermark.
- **Watermark Font**  
This specifies the font to be used for the text in the watermark.
- **Watermark Size**  
This specifies the font size to be used for the text in the watermark.
- **Watermark Color**  
This specifies the color of the text in the watermark.
- **Watermark Intensity**  
This specifies the density of the text in the watermark.

# Supply Levels

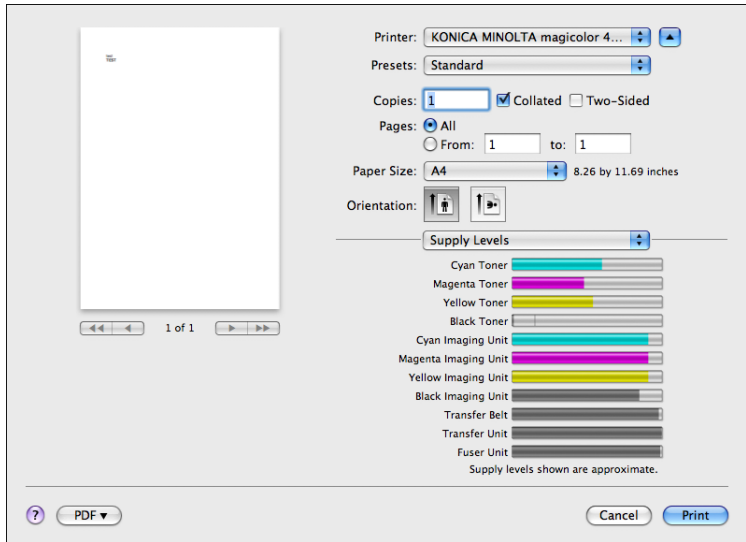

The **Supply Levels** section provides information for checking the amount of service life remaining on each consumable.



*The **Supply Levels** section appears when a printer is created on Mac OS X v10.5 with a Bonjour, IPP, LPD, Socket connection.*



*The **Supply Levels** section may not appear depending on the application you use.*

# Summary

The **Summary** is used to check the currently selected print settings.

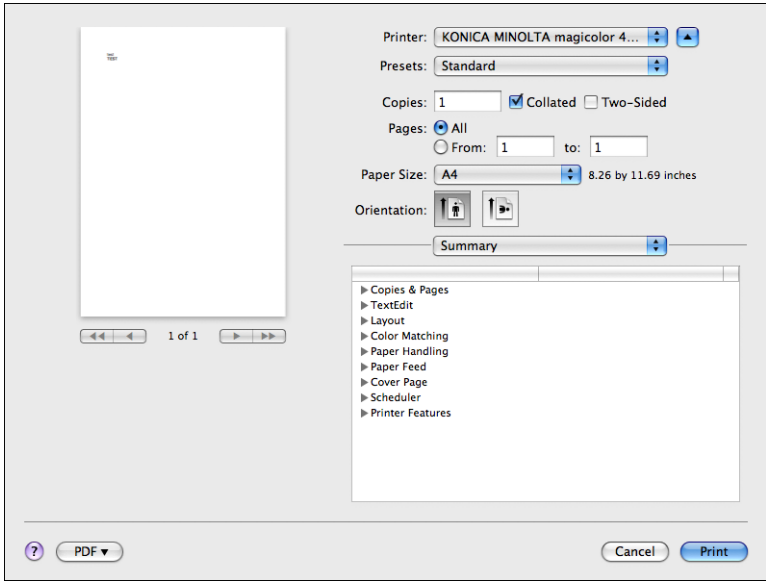

# System Requirements for the Scanner Driver

Before installing the scanner driver, make sure that your system meets the following system requirements.

Computer	Apple Macintosh computer installed with the following processor: <ul style="list-style-type: none"><li>– PowerPC G3 or later processor (PowerPC G4 or later is recommended)</li><li>– Intel processor</li></ul>
Connecting the computer and printer	USB connection, Network connection (10 Base-T/100 Base-TX)
Operating system	Mac OS X 10.2.8 or later
RAM	128 MB or more
Available disk space	256 MB or more (for storing images)
Supported languages	English, French, German, Italian, Spanish, Portuguese, Russian, Czech, Slovak, Hungarian, Polish, Japanese, Korean, Simplified Chinese, Traditional Chinese

# Installing the Scanner Driver



You must have administrator privileges in order to install the scanner driver.



Before proceeding with the installation, be sure to exit all running applications.



In the following text, “TWAIN driver” may be used to indicate the scanner driver.

## Installing the Scanner Driver



The procedure for installing the printer driver on Mac OS X 10.4 is described below. The following procedure or some steps may be different depending on the version of the operating system being used. Complete the installation according to the instructions in the dialog boxes that appear.

- 1 Insert the Drivers CD/DVD in the CD/DVD-ROM drive of your Macintosh.
- 2 Double-click the CD icon on the desktop, Mac folder, Scanner Driver folder, and then double-click the **KONICA MINOLTA mc4690MF Scanner.pkg**.



The installer for the printer driver starts up.

### 3 Click **Continue**.

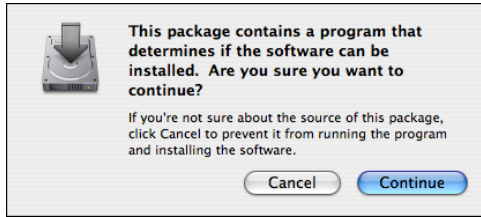

### 4 Click **Continue**.

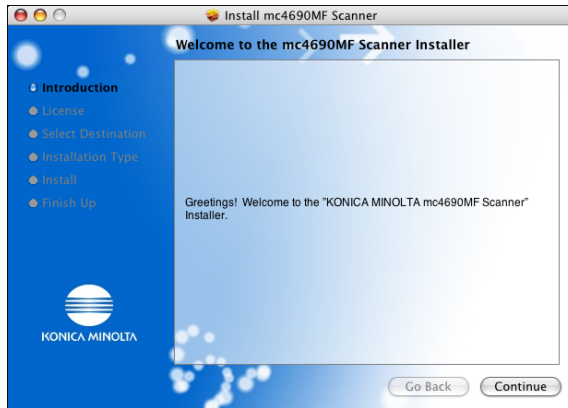

### 5 Check the details of the license agreement, and then click **Continue**.

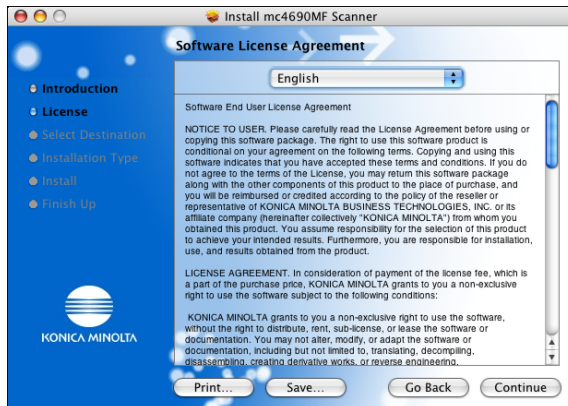

- 6 Click **Agree** in the confirmation dialog box if you agree to the terms of the license.



- 7 In the **Select a Destination** page, select the disk in which you wish to install the software, and then click **Continue**.

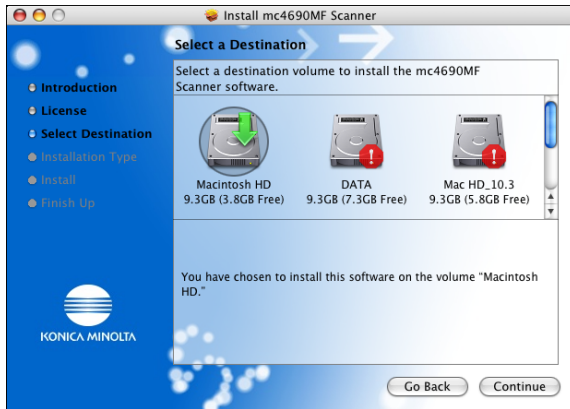

- 8 Click **Install** in the **Easy Install** page.

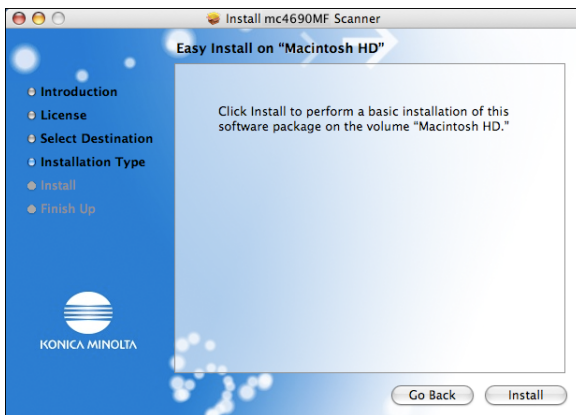

- 9 Enter the administrator user name and password in the Authenticate dialog box, and then click **OK**.

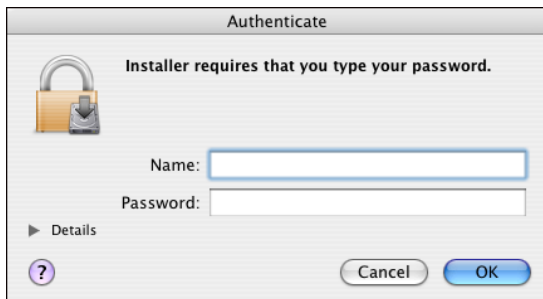

Installation starts.

- 10 After the installation has been completed, click **Close**.

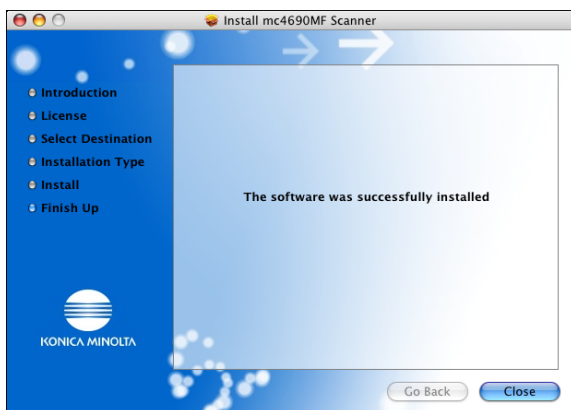

This completes the installation of the scanner driver.

# Scanning From a Computer Application

Documents can be scanned from a computer connected to this machine with a USB cable or via a network. Scanning settings can be specified and the scanning operation can be performed from TWAIN-compatible applications. From the scanner driver, a preview can be displayed and various adjustments, such as the size of the scan area can be specified.

## Basic Scanning Operation

- 1 Place the document to be scanned in the ADF or on the original glass.
- 2 Start the application to be used for scanning.
- 3 Start the scanner driver according to the application settings.
  - When connecting via network, select **KONICA MINOLTA mc4690MF Network**.
  - When connecting with a USB cable, select **KONICA MINOLTA mc4690MF**.
- 4 Specify the necessary scanner driver settings.
  -  *For details on scanner driver setting, refer to “Specify the Scan Settings” on page 83.*
- 5 Click the **Scan** button in the scanner driver.

# Specify the Scan Settings

## Auto Scanning Mode

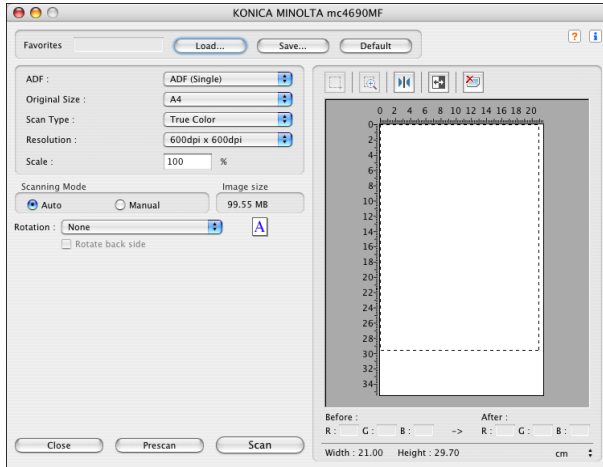

- Load  
Specify a saved settings file (dat file) for scanning.
- Save  
Save the current settings as a settings file (dat file).
- Default  
Return all settings to their defaults.
- Help icon  
Click to display the Help.
- About icon  
Click to display the software version information.
- ADF  
With scanning documents from the ADF, select whether to scan only the front side or both sides of the document.
- Original Size  
Specify the original size.
- Scan Type  
Specify the scan type.
- Resolution  
Specify the resolution.
- Scale  
Shows the width and height of the area to be scanned.

- **Scanning Mode**  
Select **Auto** or **Manual**. When **Manual** is selected, settings can be specified for **Brightness/Contrast, Filter, Curves, Levels, Color Balance** and **Hue/Saturation**.
- **Image size**  
Shows the data size of the scan image.
- **Rotation**  
The TWAIN driver support 4 kinds of rotation type: None, Right 90, Left 90, 180.



*When **ADF (Duplex)** is selected, **Rotate back side** check box can be selected for **Rotation**.*

- **Close**  
Click to close the TWAIN driver window.
- **Prescan**  
Displays a preview in the preview window.
- **Scan**  
Click to begin scanning.
- **AutoCrop**  
Selects an area of the scanned image.
- **Zoom**  
Zooms in on the scanned image.
- **Mirror**  
Displays a mirror image of the preview image.
- **Tone Reversal**  
Reverses the colors of the preview image
- **Clear**  
Erases the preview.

# Manual Scanning Mode

When **Manual** is selected for Scanning Mode, various setting for scanning tone are available.

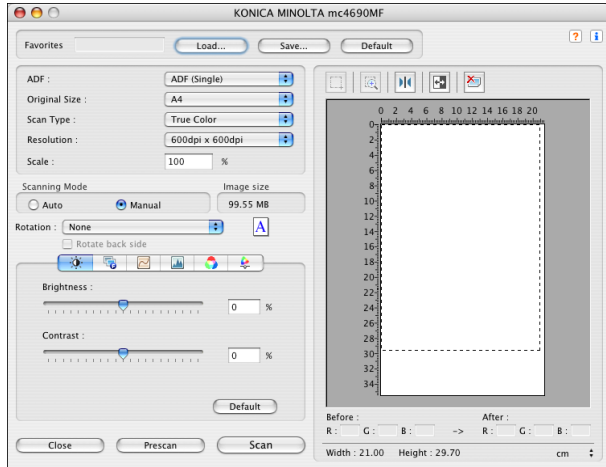

## ■ Brightness/Contrast

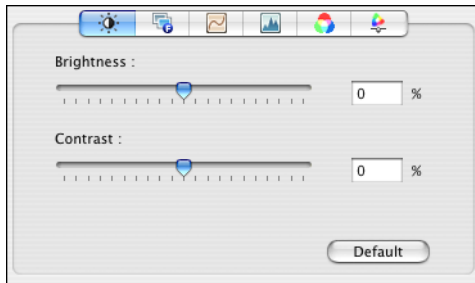

This function is used to set the brightness and contrast of the image.

■ Filter

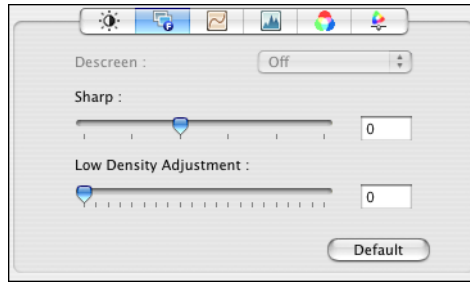

This function is used to sharpen the image or blur it for special effect.

■ Curves

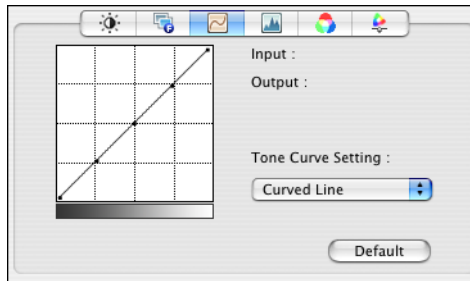

This function is used to set the gamma of the image. In the graph, the X-axis represents the input level, and the Y-axis represents the output level. The selections include, 'Value Input', 'Folded Line', and 'Curved Line'. There are three input controls available: the scroll bar, the editing field, or by directly dragging the points of the folded or curved lines. This function will allow you to brighten or darken the overview of the image without changing the original resolution of the image.



*The scroll bar and editing field are displayed when 'Value Input' is selected.*

## ■ Levels

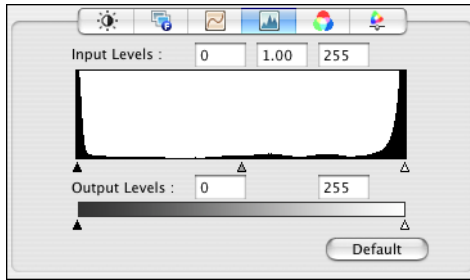

This function is used to set the gamma value, increase shadow and high-light areas, enhance shadow value and reduce highlight value. The X-axis indicates the scaling value and the Y-axis indicates the pixel value. The shadow, gamma and highlight values for the scanned image can be adjusted by dragging the triangular pointer right below the X-axis. Using the output level to adjust the range of brightness.

## ■ Color Balance

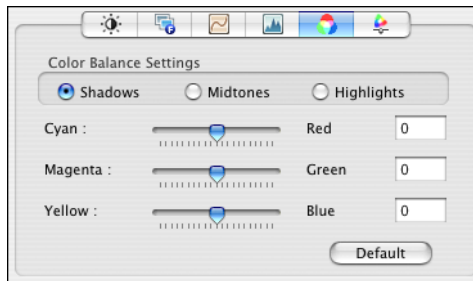

This function is used to fine-tune the RGB values in shadows, midtones, and highlights areas.

■ Hue/Saturation

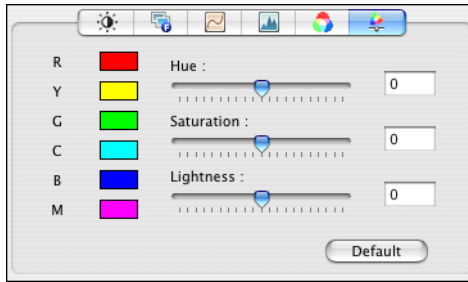

This function is used to set hue and saturation as well as the lightness of the image.

# Troubleshooting

Symptom	Solution
The setting in the saved presets are not applied.	Depending on the functions selected for the printer, some preset settings are not saved.
Media type error appears.	If a media type, such as "Transparency", is specified for Tray 2, a media type error appears and the printer stops. Be sure to specify a media type supported by Tray 2.
The printer stops responding.	Depending on the operating system, some paper size and paper type combinations are not permitted. If the job was sent with an incorrect combination of settings, the printer stops responding. Be sure to print with the correct combination of paper size and paper type settings.
The printer is not detected using Rendezvous/Bonjour.	Using Administrator mode in PageScope Web Connection, select the <b>Enable</b> from the <b>Bonjour</b> list on the <b>Bonjour</b> page.
Checking the version number of the printer driver.	<ul style="list-style-type: none"> <li>■ For Mac OS X 10.4: Select the printer from Printer Setup Utility, and then click <b>Show Info</b> in the <b>Printers</b> menu. In the pop-up menu of the Printer Info dialog box, select <b>Name &amp; Location</b>.</li> <li>■ For Mac OS X 10.5: Select the printer from <b>Print &amp; Fax</b>, and then click <b>Options &amp; Supplies</b>. Click <b>General</b> tab.</li> </ul>
The dialog box may appear unusual when selecting other manufacturer printer and back to magicolor.	Close the Print dialog box, and then open it again.
The custom paper size is different from the size that was set.	Depending on the operating system, the custom paper size settings may change slightly due to OS round of errors in unit conversion (for example, 5.80" may change to 5.79").

Symptom	Solution
When printing 2 pages on a single sheet of paper, the pages are not centered on the paper.	Depending on the operating system, the pages are not centered on the paper when printing two pages on a single sheet of paper with the following paper sizes.  Legal, Letter Plus, Foolscap, Government Legal, Statement, Folio
When printing multiple copies of multiple pages on a single sheet of paper with <b>Collated</b> selected, the pages are printed continuously.	When printing multiple copies of multiple pages on a single sheet of paper, <b>Collated</b> cannot be selected.
While printing from Acrobat Reader, the pages are not correctly collated or the print job is cancelled.	If a printing error occurs with Acrobat Reader, print using the preview feature provided by the operating system.
When using Mac OS X 10.2/10.3 to print multiple double-sided copies of an odd number of pages with the <b>Collated</b> check box selected, the first page of the second set is printed as the last page of the previous set.	Clear the <b>Collated</b> check box before printing. Otherwise, set the number of copies to <b>1</b> , and then print the document multiple times.
When using Mac OS X 10.3/10.4/10.5 to make double-sided prints of an odd number of pages with two pages per sheet and a watermark selected, the watermark is printed on the last page.	When printing with the settings described at the left, the watermark is also printed on the last page.
When printing with <b>Resolution</b> set to <b>2400×600 DPI</b> , some fonts are not printed correctly.	Change the fonts that are not printed correctly.
When using Mac OS X 10.5 to print PowerPoint data, the image is printed at the left.	Use the dedicated driver on the Drivers CD/DVD.

Symptom	Solution
When using Mac OS X 10.5, constraint processing is not applied during printing if certain settings have been specified.	This is a limitation of the operating system. Check the Apple database.
When Mac OS X 10.4 is used to send a job with a custom paper size that has a width of 21.6 cm, Letter-size paper is requested.	Change the width of the custom paper size to 21.59 cm, and then try sending the job again.



---

*Using LinkMagic*

---

**2**

---

## About LinkMagic

By installing LinkMagic on a computer connected to this machine, the following operations can be performed from the computer.

- Saving scanned images as files
- Saving scanned images to the Clipboard
- Attaching scanned images to an E-mail message
- Printing scanned images
- Registering frequently used software

## LinkMagic Operating Environment



*In the following text, "TWAIN driver" may be used to indicate the scanner driver.*

The following environment is required in order to install LinkMagic onto a computer.

Item	Operating Environment
Operating System	Windows 2000 Professional (SP4 or later) Windows 2000 Server (SP3 or later) Windows XP Home Edition (SP2 or later) Windows XP Professional (SP2 or later) Windows Server 2003 Standard Edition (SP2 or later) Windows Vista
Compatible E-mail Applications	Microsoft Outlook Express ver.6.0 Microsoft Outlook 2000/2003/XP/2007 EUDORA 7.0.1 Netscape Messenger 7.1 Windows Mail ver.6.0 Lotus Notes Client 7.0.2/8
Supported languages	English, French, German, Italian, Spanish, Portuguese, Russian, Czech, Slovak, Hungarian, Polish, Japanese, Korean, Simplified Chinese, Traditional Chinese



*The printer driver for this machine and the TWAIN driver must be installed on the computer.*

# Before Using LinkMagic

Before using LinkMagic, connect the machine to the computer with the USB cable or via a network, and then install LinkMagic on the computer.

- 1 Use the USB cable or Ethernet cable to connect this machine to the computer.
- 2 Install the TWAIN driver and printer driver included with the machine.
- 3 Install LinkMagic onto the computer.



*For details on the installation procedure, refer to “Installing LinkMagic” on page 95.*

## Installing LinkMagic

- 1 Insert Applications CD/DVD in your CD/DVD-ROM drive.
- 2 Select the language.
- 3 From the Application Setup dialog, select “LinkMagic”, and then click “Install”.  
The installer starts up.
- 4 Click the **Next** button, and then follow the on-screen instructions.

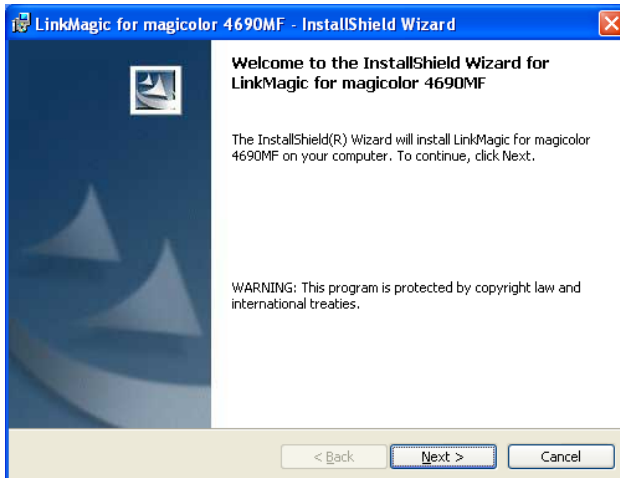

- 5 When a message appears, indicating that the installation of LinkMagic is finished, click the **Finish** button.

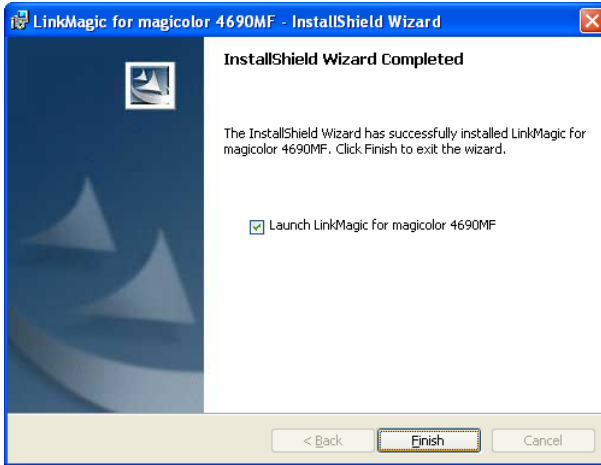

*The installation of LinkMagic is completed.*

## Starting Up LinkMagic

LinkMagic can be set to automatically start up when the computer starts up. When LinkMagic is running, the following icon appears in the taskbar of the computer.



# Main LinkMagic Window

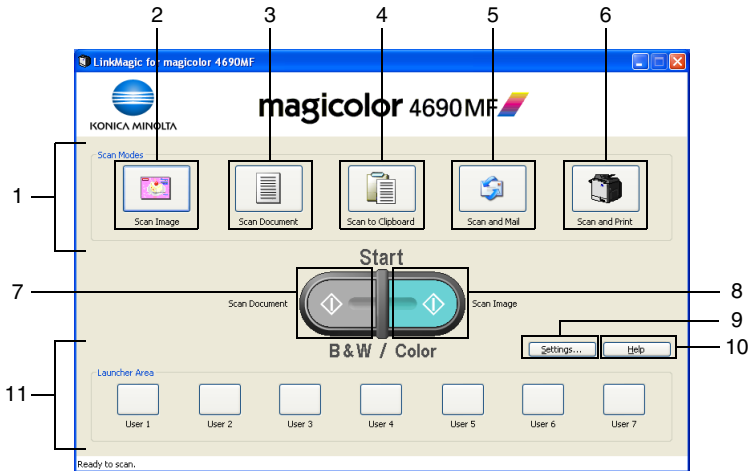

No.	Name	Description
1	“Scan Modes” group box	This group box contains buttons programmed with various LinkMagic functions.
2	<b>Scan Image</b> button	Click this button to save the image scanned with the machine as a file on the computer.  In addition, clicking this button starts the previously specified software.  Clicking this button displays the Scan Image dialog box. (=>“Saving Scanned Images as Files” on page 99)
3	<b>Scan Document</b> button	Click this button to save the image scanned with the machine as a file on the computer.  In addition, clicking this button starts the previously specified software.  Clicking this button displays the Scan Document dialog box. (=>“Saving Scanned Images as Files” on page 99)
4	<b>Scan to Clipboard</b> button	Click this button to save the image scanned with the machine to the computer Clipboard.  Clicking this button displays the Scan to Clipboard dialog box. (=>“Saving Scanned Images to the Clipboard” on page 104)

No.	Name	Description
5	<b>Scan and Mail</b> button	<p>Click this button to save the image scanned with the machine as a file on the computer, and attach it to an E-mail message.</p> <p>Clicking this button displays the Scan and Mail dialog box. (=&gt;“Attaching Scanned Images to an E-Mail Message” on page 109)</p>
6	<b>Scan and Print</b> button	<p>Click this button to print from a printer the image scanned with the machine.</p> <p>Clicking this button displays the Scan and Print dialog box. (=&gt;“Printing Scanned Images” on page 116)</p>
7	Link to <b>Start—Color</b> key	<p>A function from the “Scan Modes” group box can be assigned to the <b>Start—Color</b> key.</p> <p>Pressing the <b>Start—Color</b> key on the machine performs the assigned function.</p>
8	Link to <b>Start—B&amp;W</b> key	<p>A function from the “Scan Modes” group box can be assigned to the <b>Start—B&amp;W</b> key.</p> <p>Pressing the <b>Start—B&amp;W</b> key on the machine performs the assigned function.</p>
9	<b>Settings</b> button	<p>Clicking this button displays the Settings dialog box.</p> <p>(=&gt;“Settings Dialog Box” on page 124)</p>
10	<b>Help</b> button	<p>Clicking this button displays the Help.</p>
11	Launcher Area	<p>Frequently used software can be registered.</p> <p>Clicking this button starts the registered software.</p> <p>(=&gt;“Registering Frequently Used Software” on page 122)</p>

# Using LinkMagic

## Saving Scanned Images as Files

An image scanned with the machine can be saved as a file on the computer. In addition, the previously specified software can be started.



*For details on the settings available in the Scan Image dialog box and the Scan Document dialog box, refer to “Description of the Scan Image/Scan Document Dialog Boxes” on page 100.*

- 1 In the “Scan Modes” group box of the main window, click the **Scan Image** or **Scan Document** button.
- 2 Select “Local Scanner (USB)” or “Network Scanner” for the connected scanner, and then click **OK** button.  
The Scan Image or Scan Document dialog box appears.

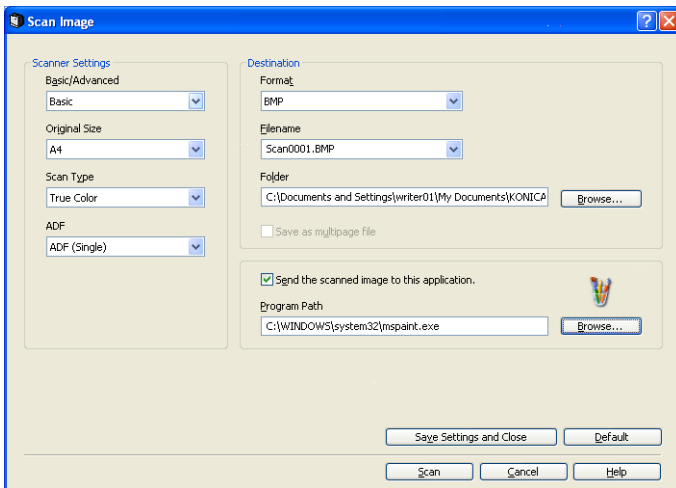

- 3 From the “Basic/Advanced” list in the “Scanner Settings” group box, select the general scan setting.
  - If “Basic” is selected, scans will be produced with the basic settings. In the “Scanner Settings” group box, select the document size from the “Original Size” list, the document color type from the “Scan Type” list then, select whether a single-sided or double-sided document is to be scanned with the “ADF”.
  - If “Advanced” is selected, specify detailed settings from the TWAIN driver dialog box that appears.



For details on the available TWAIN driver settings, refer to the *Printer/Copier/Scanner User's Guide on the Documentation CD/DVD*.

- 4 In the "Destination" group box, specify the settings for saving the scanned image.



When "Advanced" is selected, the TWAIN driver starts up. However, clicking the *Scan Image* or *Scan Document* dialog box allows the settings in the "Destination" group box to be changed.

- 5 To start up software and display the scanned image after the image is scanned, select the "Send the scanned image to this application." check box, and then specify the software to be started up.





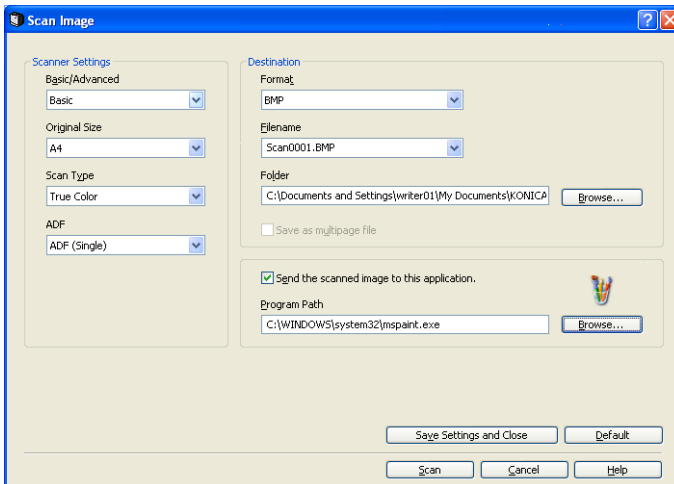

Specify software compatible with the file format selected in the "Format" list.

- 6 Click the **Scan** button.  
Scanning begins, and the image is saved in the specified location.

## Description of the Scan Image/Scan Document Dialog Boxes



Name	Description
"Scanner Settings" group box	Select the settings for scanning the image.
"Basic/Advanced" list	<p>Select the general scan setting. If "Basic" is selected, specify basic settings from the "Original Size", "Scan Type", and "ADF" lists. If "Advanced" is selected, detailed settings can be specified from the TWAIN driver dialog box that appears.</p> <p> <i>The resolution is 300 dpi when "Basic" is selected.</i></p> <p>Choices: Basic, Advanced</p> <p>Default: Basic</p>
"Original Size" list	<p>Select the size of the document. These settings are available when "Basic" is selected in the "Basic/Advanced" list.</p> <p>If "Custom Size" is selected, a new paper size setting can be added from the Custom Size Setting dialog box that appears.</p> <p>Choices: A4, B5, A5, Legal, Letter, Custom Size</p> <p>Default: Letter (English), A4 (except English)</p> <p>■ Custom Size Settings  Width: 15 - 215 mm (0.5 - 8.50 in)  Height: 15 - 355 mm (0.5 - 14.00 in)  Unit: mm, in</p>
"Scan Type" list	<p>Select the color type of the document. These settings are available when "Basic" is selected in the "Basic/Advanced" list.</p> <p>Choices: B/W, Gray, True Color</p> <p>Default: True color with <b>Scan Image</b>, B/W with <b>Scan Document</b></p>

Name	Description
"ADF" list	<p>Select whether a single-sided or double-sided document is to be scanned.</p> <p>Choices: ADF (Single), ADF (Duplex)</p> <p>Default: ADF (Single)</p> <p> <i>When duplex page is scanned from ADF, first page is surface and second page is back side of it.</i></p> <p> <i>When document is not set on the ADF, this setting will be ignored.</i></p>
"Destination" group box	Select the settings for saving scanned images.
"Format" list	<p>Select the file format for the scanned image.</p> <p>Choices: BMP, JPEG, PDF, TIFF</p> <p>Default: BMP</p>
"Filename" list	<p>Specify the number to be added to the file name for the scanned image to be saved.</p> <p>Even if a new file name has been specified, file names that have been used can also be selected from the list.</p> <p> <i>If there are no numbers at the end of the specified file name, "0001" is automatically added.</i></p> <p> <i>If the extension of a file format compatible with LinkMagic is added to the specified file name, the extension of a file is automatically saved in that file format.</i></p> <p>Range: Up to 255 characters</p> <p>Default: "Scan0001"+ extension</p>

Name	Description
"Folder" text box	<p>Specify the name of the folder where the scanned image is to be saved.</p> <p>To display the Browse for Folder dialog box in order to browse to a folder on the computer, click the <b>Browse</b> button.</p> <p>Range: Up to 255 characters</p> <p>Default: \Documents and Settings\[Login user name]\My Documents\KONICA MINOLTA\Link-Magic for magicolor 4690MF\MyData</p>
"Save as multi-page file" check box	<p>Select this check box to save the file in a multi-page format when images are scanned continuously with the ADF.</p> <p> <i>This option is available when "TIFF" or "PDF" is selected in the "Format" list.</i></p> <p>Default: Checked</p>
"Send the scanned image to this application." check box	<p>Select this check box to start up the specified software and open the scanned image file after the image is scanned.</p> <p>Default: Unchecked</p>
"Program Path" text box	<p>Specify the software to be used to open the scanned image.</p> <p>To browse to software on the computer, click the <b>Browse</b> button.</p> <p>Range: Up to 259 characters</p> <p>Default: [Blank]</p>
<b>Save Settings and Close</b> button	Click this button to save the current settings and close this dialog box.
<b>Default</b> button	Click this button to return all dialog box items to their default settings.
<b>Scan</b> button	Click this button after selecting "Basic" in the "Basic/Advanced" list to begin scanning the image.
<b>Cancel</b> button	Click this button to close this dialog box without saving the changes to the settings.
<b>Help</b> button	Click this button to display the Help.

## Saving Scanned Images to the Clipboard

An image scanned with the machine can be copied to the Clipboard.

In addition, the area to be copied to the Clipboard can be selected.



*For details on the settings available in the Scan to Clipboard dialog box, refer to “Description of the Scan to Clipboard Dialog Box” on page 106.*



*With this procedure, the ADF cannot be used to scan continuously. If multiple pages are scanned, only the first page is displayed in the preview area.*

- 1 In the “Scan Modes” group box of the main window, click the **Scan to Clipboard** button.
- 2 Select “Local Scanner (USB)” or “Network Scanner” for the connected scanner, and then click **OK** button.  
The Scan to Clipboard dialog box appears.

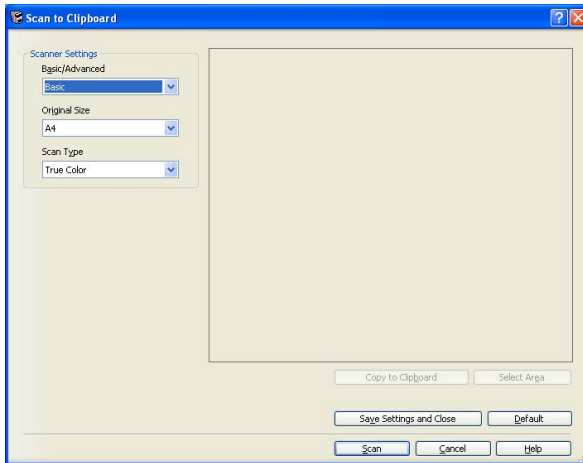

- 3 From the “Basic/Advanced” list in the “Scanner Settings” group box, select the general scan setting.
  - If “Basic” is selected, scans will be produced with the basic settings. In the “Scanner Settings” group box, select the document size from the “Original Size” list and the document color type from the “Scan Type” list.
  - If “Advanced” is selected, specify detailed settings from the TWAIN driver dialog box that appears.



For details on the available TWAIN driver settings, refer to the *Printer/Copier/Scanner User's Guide on the Documentation CD/DVD*.

**4** Click the **Scan** button.

Scanning begins, and the image is displayed on the right side of the dialog box.

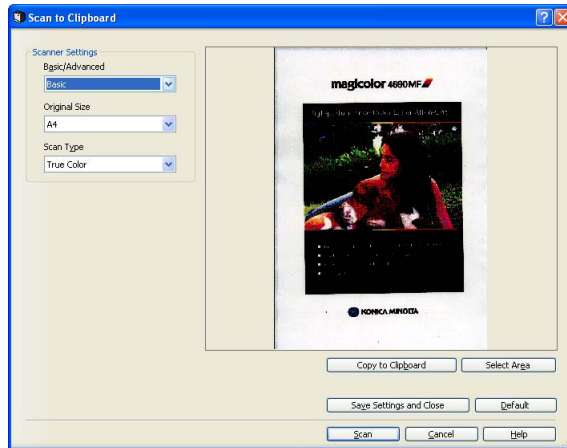

**5** To select the area of the image to be copied, click the **Select Area** button, and then drag the pointer to select the area to be copied.





To cancel selection of the selected area, click the **Delete Selection** button.

**6** Click the **Copy to Clipboard** button.

The scanned image is copied to the Clipboard.

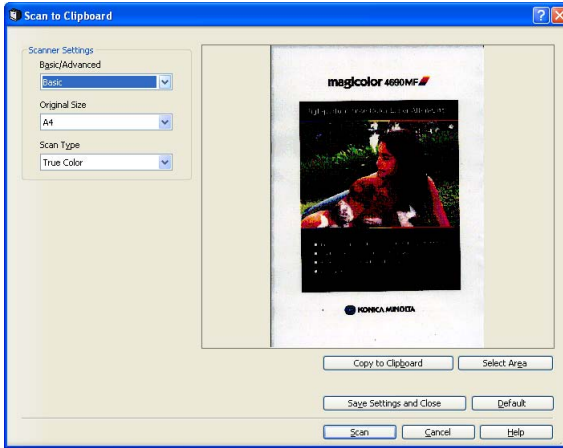
## Description of the Scan to Clipboard Dialog Box



Name	Description
"Scanner Settings" group box	Select the settings for scanning the image.
"Basic/Advanced" list	<p>Select the general scan setting.</p> <p>If "Basic" is selected, specify basic settings from the "Original Size" and "Scan Type" lists.</p> <p>If "Advanced" is selected, detailed settings can be specified from the TWAIN driver dialog box that appears.</p> <p> <i>The resolution is 150 dpi when "Basic" is selected.</i></p> <p>Choices: Basic, Advanced</p> <p>Default: Basic</p> <p> <i>If "Advanced" is selected, an image up to 4 GB can be scanned (depends on the memory capacity of PC). The approximate image size can be checked from the TWAIN driver.</i></p>

Name	Description
	<p data-bbox="313 121 508 148">"Original Size" list</p> <p data-bbox="527 121 1034 204">Select the size of the document. These settings are available when "Basic" is selected in the "Basic/Advanced" list.</p> <p data-bbox="527 228 1034 311">If "Custom Size" is selected, a new paper size setting can be added from the Custom Size Setting dialog box that appears.</p> <p data-bbox="527 331 1034 359">Choices: A4, B5, A5, Legal, Letter, Custom Size</p> <p data-bbox="527 379 1003 406">Default: Letter (English), A4 (except English)</p> <ul style="list-style-type: none"> <li data-bbox="527 427 788 454">■ Custom Size Settings <ul style="list-style-type: none"> <li data-bbox="557 454 919 481">Width: 15 - 215 mm (0.5 - 8.50 in)</li> <li data-bbox="557 481 938 509">Height: 15 - 355 mm (0.5 - 14.00 in)</li> <li data-bbox="557 509 687 536">Unit: mm, in</li> </ul> </li> </ul>
	<p data-bbox="313 552 482 579">"Scan Type" list</p> <p data-bbox="527 552 1034 635">Select the color type of the document. These settings are available when "Basic" is selected in the "Basic/Advanced" list.</p> <p data-bbox="527 655 863 683">Choices: B/W, Gray, True Color</p> <p data-bbox="527 703 732 730">Default: True Color</p>
Preview area	The scanned image appears on the right side of the dialog box.
<b>Copy to Clipboard</b> button	<p data-bbox="527 812 1034 866">Click this button to copy the image displayed in the preview area to the Clipboard.</p> <p data-bbox="527 887 1034 914">If an area was selected, only that area is copied.</p>
<b>Select Area</b> button/ <b>Delete Selection</b> button	<p data-bbox="527 927 1034 981">To select the area to be copied from the preview area, click the <b>Select Area</b> button.</p> <p data-bbox="527 1002 972 1056">When the <b>Select Area</b> button is clicked, it changes to the <b>Delete Selection</b> button.</p> <p data-bbox="527 1077 1034 1131">To cancel the selection, click the <b>Delete Selection</b> button again.</p>
<b>Save Settings and Close</b> button	Click this button to save the current settings and close this dialog box.
<b>Default</b> button	Click this button to return all dialog box items to their default settings.
<b>Scan</b> button	Click this button after selecting "Basic" in the "Basic/Advanced" list to begin scanning the image.

Name	Description
<b>Cancel</b> button	Click this button to close this dialog box without saving the changes to the settings.
<b>Help</b> button	Click this button to display the Help.

## Attaching Scanned Images to an E-Mail Message

An image scanned with the machine can be saved as a file on the computer, and attached to an E-mail message.



*This operation is compatible with the following E-mail applications.*

- Microsoft Outlook Express ver. 6.0
- Microsoft Outlook 2000/2003/XP/2007
- EUDORA 7.0.1
- Netscape Messenger 7.1
- Windows Mail ver. 6.0



*With one operation, only one file can be attached to an E-mail message. If the ADF is used to scan multiple document pages and “BMP” or “JPEG” is selected in the “Format” list, only the first page is attached to the E-mail message.*





*If “PDF” or “TIFF” is selected in the “Format” list, a multi-page file is attached.*

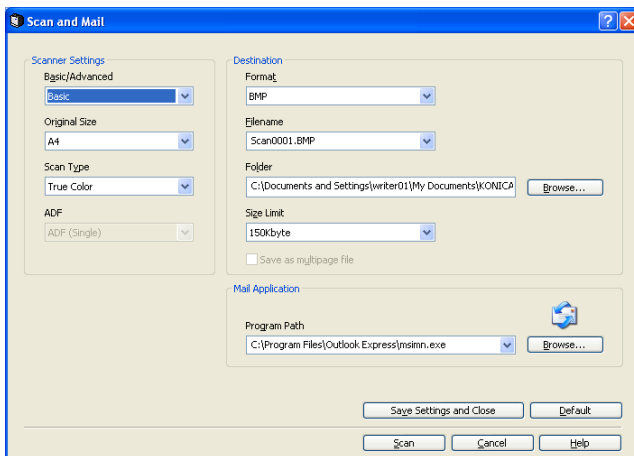

*For details on the settings available in the Scan and Mail dialog box, refer to “Description of the Scan and Mail Dialog Box” on page 111.*

- 1 In the “Scan Modes” group box of the main window, click the **Scan and Mail** button.
- 2 Select “Local Scanner (USB)” or “Network Scanner” for the connected scanner, and then click **OK** button.  
The Scan and Mail dialog box appears.







- 3 From the “Basic/Advanced” list in the “Scanner Settings” group box, select the general scan setting.
  - If “Basic” is selected, scans will be produced with the basic settings. In the “Scanner Settings” group box, select the document size from the “Original Size” list and the document color type from the “Scan Type” list.
  - If “Advanced” is selected, specify detailed settings from the TWAIN driver dialog box that appears.
-  For details on the available TWAIN driver settings, refer to the Printer/Copier/Scanner User’s Guide on the Documentation CD/DVD.
- 4 In the “Destination” group box, specify the settings for saving the scanned image.
  -  When “Advanced” is selected, the TWAIN driver starts up. However, clicking the Scan and Mail dialog box allows the settings in the “Destination” group box to be changed.
  -  If “PDF” or “TIFF” is selected in the “Format” list, “ADF” of “Scanner Settings” can be specified.
- 5 From the “Size Limit” list, select the limit for the size of images to be attached to E-mail messages.
- 6 In the “Mail Application” group box, specify the application to be used for sending the message with the image attached.
  -  Check that the application automatically selected in the “Mail Application” group box is the E-mail application that is normally used.
- 7 Click the **Scan** button.

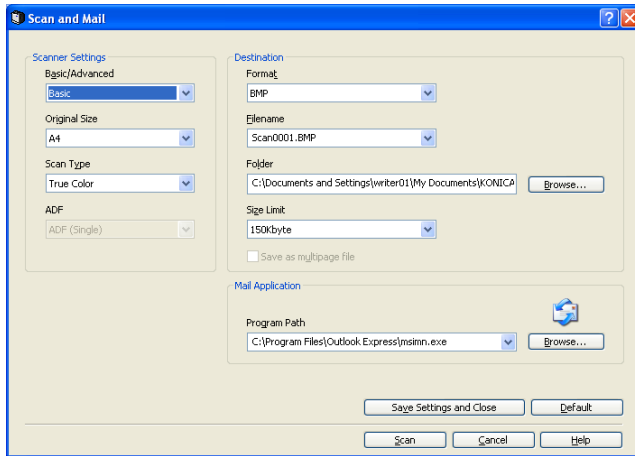

Scanning begins, and a new E-mail message is created with the scanned image attached.



  -  If the size of the scanned image file is larger than the size specified with “Size Limit”, a message appears, warning that the file is too large. Select whether to rescan the image in Advanced mode or to send it as it is.
- 8 Type in the message subject and body text, and then send the E-mail message.



## Description of the Scan and Mail Dialog Box



Name	Description
"Scanner Settings" group box	Select the settings for scanning the image.
"Basic/Advanced" list	<p>Select the general scan setting.</p> <p>If "Basic" is selected, specify basic settings from the "Original Size" and "Scan Type", and "ADF" lists.</p> <p>If "Advanced" is selected, detailed settings can be specified from the TWAIN driver dialog box that appears.</p> <p> <i>The resolution is 150 dpi when "Basic" is selected.</i></p> <p> <i>The resolution changes automatically according to the size specified with "Size Limit".</i></p> <p>Choices: Basic, Advanced</p> <p>Default: Basic</p> <p> <i>If "Advanced" is selected, an image up to 126,000 KB can be scanned. The approximate image size can be checked from the TWAIN driver.</i></p>

Name	Description
"Original Size" list	<p>Select the size of the document. These settings are available when "Basic" is selected in the "Basic/Advanced" list.</p> <p>If "Custom Size" is selected, a new paper size setting can be added from the Custom Size Setting dialog box that appears.</p> <p>Choices: A4, B5, A5, Legal, Letter, Custom Size</p> <p>Default: Letter (English), A4 (except English)</p> <ul style="list-style-type: none"> <li>■ Custom Size Settings <ul style="list-style-type: none"> <li>Width: 15 - 215 mm (0.5 - 8.50 in)</li> <li>Height: 15 - 355 mm (0.5 - 14.00 in)</li> <li>Unit: mm, in</li> </ul> </li> </ul>
"Scan Type" list	<p>Select the color type of the document. These settings are available when "Basic" is selected in the "Basic/Advanced" list.</p> <p>Choices: B/W, Gray, True Color</p> <p>Default: True Color</p>
"ADF" list	<p>Select whether a single-sided or double-sided document is to be scanned.</p> <p>Choices: ADF (Single), ADF (Duplex)</p> <p>Default: ADF (Single)</p> <p> <i>When duplex page is scanned from the ADF, first page is surface and second page is back side of it.</i></p> <p> <i>When document is not set on the ADF, this setting will be ignored.</i></p>

Name	Description
"Destination" group box	Select the settings for saving scanned images.
	<p data-bbox="311 161 504 188">"Format" list</p> <p data-bbox="527 161 1041 188">Select the file format for the scanned image.</p> <p data-bbox="527 209 873 236">Choices: BMP, JPEG, PDF, TIFF</p> <p data-bbox="527 252 672 279">Default: BMP</p>
	<p data-bbox="311 293 504 320">"Filename" list</p> <p data-bbox="527 293 1041 347">Specify the number to be added to the file name for the scanned image to be saved.</p> <p data-bbox="527 368 1041 453">Even if a new file name has been specified, file names that have been used can also be selected from the list.</p> <p data-bbox="527 474 1041 571">  <i>If there are no numbers at the end of the specified file name, "0001" is automatically added.</i> </p> <p data-bbox="527 592 1041 719">  <i>If the extension of a file format compatible with LinkMagic is added to the specified file name, the file is automatically saved in that file format.</i> </p> <p data-bbox="527 740 837 767">Range: Up to 255 characters</p> <p data-bbox="527 788 866 815">Default: "Scan0001"+ extension</p>
	<p data-bbox="311 828 504 855">"Folder" text box</p> <p data-bbox="527 828 1041 882">Specify the name of the folder where the scanned image is to be saved.</p> <p data-bbox="527 903 1041 987">To display the Browse for Folder dialog box in order to browse to a folder on the computer, click the <b>Browse</b> button.</p> <p data-bbox="527 1008 837 1035">Range: Up to 255 characters</p> <p data-bbox="527 1056 1041 1141">Default: \Documents and Settings\[Login user name]\My Documents\KONICA MINOLTA\Link-Magic for magicolor 4690MF\MyData</p>

Name	Description
<p>“Size Limit” list</p>	<p>Select the limit for the file size of images to be attached to E-mail messages.</p> <p>If “Custom” is selected, a new size limit setting can be added from the Custom Size Settings [Size Limit] dialog box that appears.</p> <p> <i>If “Basic” is selected in the “Basic/Advanced” list, the resolution is automatically reduced so that the size of the image file does not exceed the size limit specified here.</i></p> <p>Choices: 75Kbyte, 150Kbyte, 500Kbyte, 1Mbyte, 3Mbyte, None, Custom</p> <p>Default: 150Kbyte</p>
<p>“Save as multi-page file” check box</p>	<p>Select this check box to save the file in a multi-page format when images are scanned continuously with the ADF.</p> <p> <i>This option is available when “TIFF” or “PDF” is selected in the “Format” list.</i></p> <p>Default: Checked</p>
<p>“Mail Application” group box</p>	<p>Specify the E-mail application used for attaching the image.</p>

Name	Description
<p>“Program Path” list</p>	<p>Select the E-mail application from the list.</p> <p>E-mail applications installed on the computer are automatically searched for and added to the list.</p> <p>To browse to software on the computer, click the <b>Browse</b> button.</p> <p> <i>An E-mail application bundled with Windows is automatically selected. In addition, 32-bit applications are given priority during detection.</i></p> <p><i>To use a 64-bit E-mail application as the Windows-bundled software, start up the E-mail application to be used before performing the Scan and Mail operation.</i></p> <p>Range: Up to 259 characters</p> <p>Default: First E-mail application that was found</p>
<p><b>Save Settings and Close</b> button</p>	<p>Click this button to save the current settings and close this dialog box.</p>
<p><b>Default</b> button</p>	<p>Click this button to return all dialog box items to their default settings.</p>
<p><b>Scan</b> button</p>	<p>Click this button after selecting “Basic” in the “Basic/Advanced” list to begin scanning the image.</p>
<p><b>Cancel</b> button</p>	<p>Click this button to close this dialog box without saving the changes to the settings.</p>
<p><b>Help</b> button</p>	<p>Click this button to display the Help.</p>

## Printing Scanned Images

An image scanned with the machine can be printed from a printer.



For details on the settings available in the Scan and Print dialog box, refer to “Description of the Scan and Print Dialog Box” on page 118.

- 1 In the “Scan Modes” group box of the main window, click the **Scan and Print** button.
- 2 Select “Local Scanner (USB)” or “Network Scanner” for the connected scanner, and then click **OK** button.  
The Scan and Print dialog box appears.

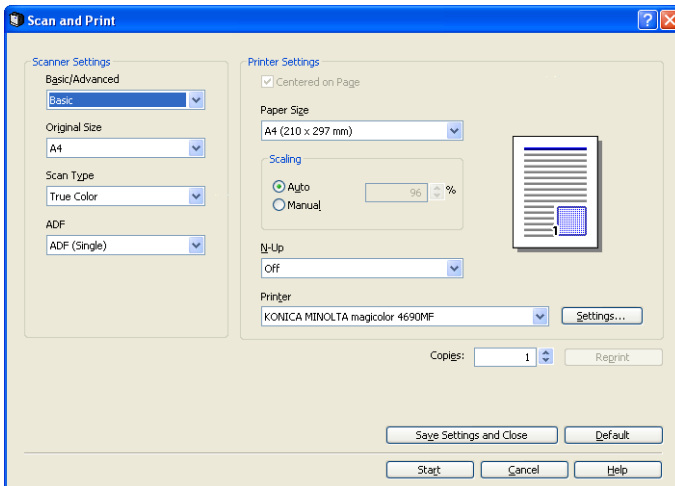

- 3 From the “Basic/Advanced” list in the “Scanner Settings” group box, select the general scan setting.
  - If “Basic” is selected, scans will be produced with the basic settings. In the “Scanner Settings” group box, select the document size from the “Original Size” list and the document color type from the “Scan Type” list then, select whether a single-sided or double-sided document is to be scanned with the ADF.
  - If “Advanced” is selected, specify detailed settings from the TWAIN driver dialog box that appears.



For details on the available TWAIN driver settings, refer to the Printer/Copier/Scanner User’s Guide on the Documentation CD/DVD.

- 4 In the “Printer Settings” group box, specify the settings for printing the scanned image.







When “Advanced” is selected, the TWAIN driver starts up. However, clicking the Scan and Print dialog box allows the settings in the “Printer Settings” group box to be changed.

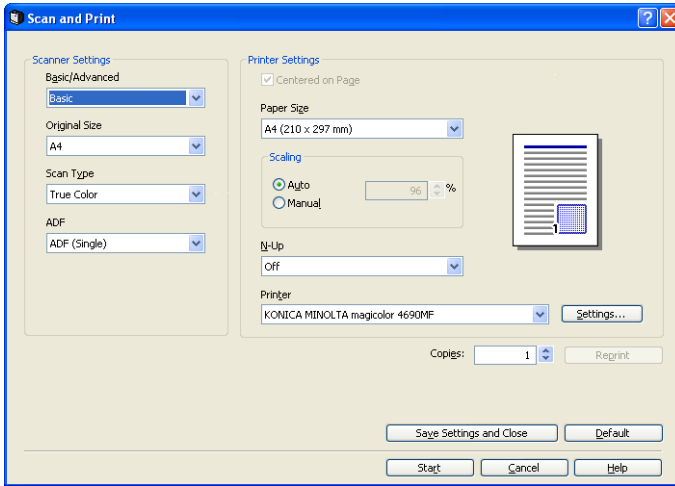

- 5 Click the **Start** button.  
Scanning begins, and the image is printed from the specified printer.



## Description of the Scan and Print Dialog Box



Name	Description
"Scanner Settings" group box	Select the settings for scanning the image.
"Basic/Advanced" list	<p>Select the general scan setting.</p> <p>If "Basic" is selected, specify basic settings from the "Original Size", "Scan Type", and "ADF" lists.</p> <p>If "Advanced" is selected, detailed settings can be specified from the TWAIN driver dialog box that appears.</p> <p> <i>The resolution is 300 dpi when "Basic" is selected.</i></p> <p>Choices: Basic, Advanced</p> <p>Default: Basic</p> <p> <i>If "Advanced" is selected, an image up to 1,760,000 KB can be scanned. The approximate image size can be checked from the TWAIN driver.</i></p>

Name	Description
"Original Size" list	<p>Select the size of the document. These settings are available when "Basic" is selected in the "Basic/Advanced" list.</p> <p>If "Custom Size" is selected, a new paper size setting can be added from the Custom Size Setting dialog box that appears.</p> <p>Choices: A4, B5, A5, Legal, Letter, Custom Size</p> <p>Default: Letter (English), A4 (except English)</p> <ul style="list-style-type: none"> <li>■ Custom Size Settings <ul style="list-style-type: none"> <li>Width: 15 - 215 mm (0.5 - 8.50 in)</li> <li>Height: 15 - 355 mm (0.5 - 14.00 in)</li> <li>Unit: mm, in</li> </ul> </li> </ul>
"Scan Type" list	<p>Select the color type of the document. These settings are available when "Basic" is selected in the "Basic/Advanced" list.</p> <p>Choices: B/W, Gray, True Color</p> <p>Default: True Color</p>
"ADF" list	<p>Select whether a single-sided or double-sided document is to be scanned.</p> <p>Choices: ADF (Single), ADF (Duplex)</p> <p>Default: ADF (Single)</p> <p> <i>When duplex page is scanned from ADF, first page is surface and second page is back side of it.</i></p> <p> <i>When document is not set on the ADF, this setting will be ignored.</i></p>

Name	Description
"Printer Settings" group box	Specify the settings for printing the scanned image.
"Centered on Page" check box	<p>If this check box is selected while "Manual" is selected below "Scaling", the image will be printed at the center of the printable area.</p> <p>Default: Checked</p>
"Paper Size" list	<p>Select the size of paper that is to be printed.</p> <p> <i>The orientation of the paper to be printed on cannot be changed. The image is normally printed with the paper in the portrait orientation.</i></p> <p>Choices: Paper sizes available with the selected printer</p> <p>Default: Paper specified by the selected printer</p>
"Scaling" group box	<p>Specify how the image to be printed is enlarged or reduced.</p> <p>Select "Auto" to enlarge or reduce the image according to the paper size selected in the "Paper Size" list.</p> <p>Select "Manual" to specify the enlargement or reduction ratio.</p> <p>Choices: Auto, Manual</p> <p>Default: Auto</p> <p> <i>If "Manual" is selected, a value between 25% and 400% can be specified. The default setting is 100%.</i></p>
"N-Up" list	<p>Multiple image pages can be printed together on a single sheet of paper.</p> <p>Choices: Off, 2 in 1, 4 in 1</p> <p>Default: Off</p>
"Printer" list	<p>Select the printer to be used for printing.</p> <p>Choices: Printers connected to the computer</p>

Name	Description
"Copies" text box	<p>Specify the number of copies to be printed.</p> <p> <i>The number of copies can be set between 1 and 99. The default setting is "1".</i></p>
<b>Reprint</b> button	<p>The image that had just been printed can be printed again.</p> <p>Click this button to specify the number of copies to be printed in the Reprint dialog box that appears.</p> <p> <i>The <b>Reprint</b> button is not available if the Scan and Print dialog box had been closed.</i></p> <p> <i>The number of copies can be set between 1 and 99. The default setting is "1".</i></p>
<b>Save Settings and Close</b> button	Click this button to save the current settings and close this dialog box.
<b>Default</b> button	Click this button to return all dialog box items to their default settings.
<b>Scan</b> button	Click this button after selecting "Basic" in the "Basic/Advanced" list to begin scanning the image.
<b>Cancel</b> button	Click this button to close this dialog box without saving the changes to the settings.
<b>Help</b> button	Click this button to display the Help.

## Registering Frequently Used Software

Frequently used software can be registered with launcher buttons. Clicking a launcher button starts up the registered software.



*The launcher buttons are automatically programmed with the following software if they are installed on the computer.*

- Microsoft Word 2000/XP/2003/2007
- Microsoft Excel 2000/XP/2003/2007
- Microsoft PowerPoint 2000/XP/2003/2007
- PaperPort 10 SE/11 SE
- Fax Talk 4.7
- Adobe Photoshop CS2/CS3

## Registering Software With Launcher Buttons

- 1 Right-click a button below “Launcher Area”, and then click “Launcher Button Setting”.

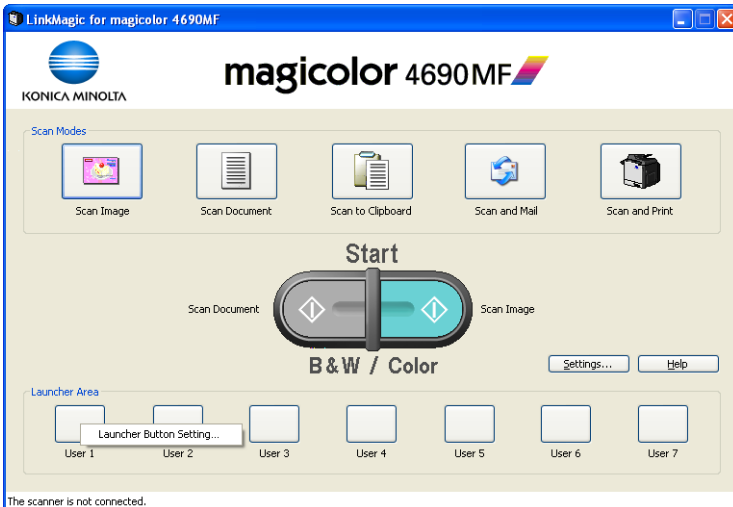

The Launcher Button Setting dialog box appears.

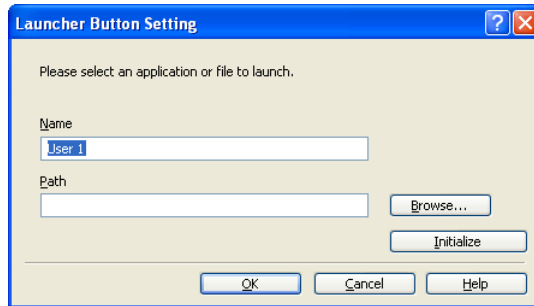

- 2 In the “Name” text box, type the name of the button.
  - A maximum of 30 characters can be entered.
- 3 In the “Path” text box, type the path to the software to be registered.
  - To browse to software on the computer, click the **Browse** button.
  - A maximum of 259 characters can be entered.
- 4 Click the **OK** button.

The software is registered with the launcher button.



Click the **Initialize** button to reset the settings to their defaults.

# Settings Dialog Box

Clicking the **Settings** button in the main window displays the Settings dialog box.

## Push To Scan Tab

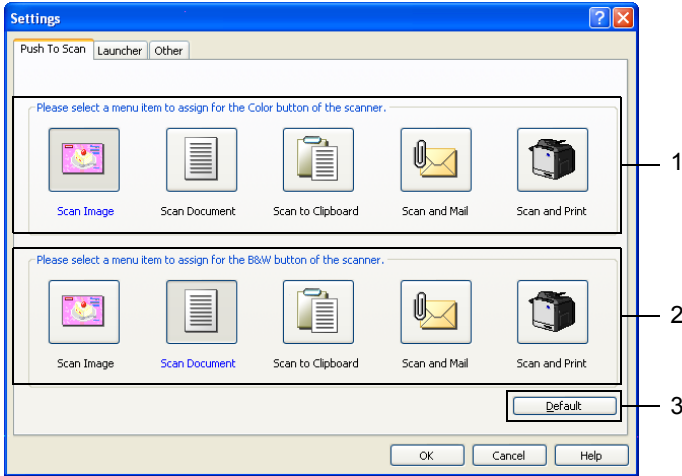

No.	Item	Description
1	Assigned link to <b>Start—Color</b> key	Select the button for the function to be assigned to the <b>Start—Color</b> key on the machine. Default: Scan Image
2	Assigned link to <b>Start—B&amp;W</b> key	Select the button for the function to be assigned to the <b>Start—B&amp;W</b> key on the machine. Default: Scan Document
3	<b>Default</b> button	Click this button to return all items to their default settings.



*The same function cannot be assigned to both the **Start—Color** key and the **Start—B&W** key.*

# Launcher Tab

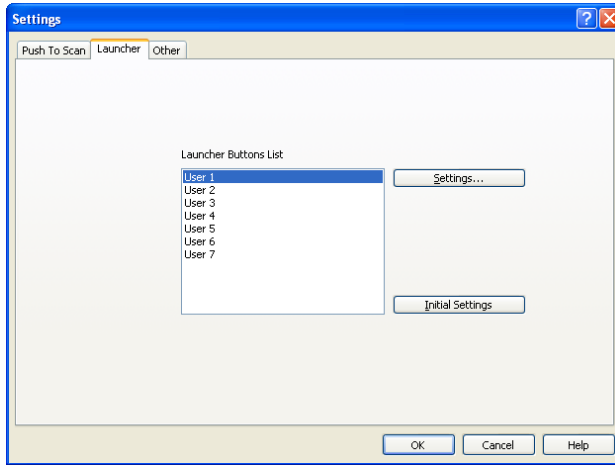

Item	Description
<b>Settings</b> button	Clicking this button to display the settings dialog box for the button selected in the "Launcher Buttons List".  (=>"Registering Frequently Used Software" on page 122)
<b>Initial Settings</b> button	Click this button to return all settings to their defaults.

## Other Tab

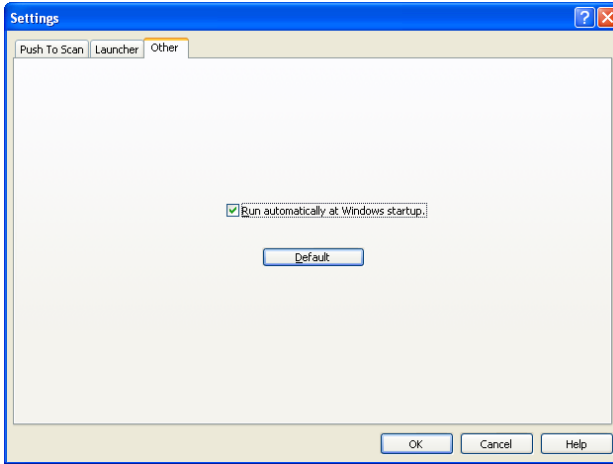

Item	Description
"Run automatically at Windows startup." check box	Select this check box to automatically start LinkMagic when the computer is started up. Default: Checked
<b>Default</b> button	Click this button to return all settings to their defaults.

# Uninstalling LinkMagic

The LinkMagic can be uninstalled using either of the following two methods.

- Using “Add or Remove Programs” (“Add/Remove Programs” with Windows 2000)
- Using setup.exe in the LinkMagic folder of the magicolor 4690MF Applications CD/DVD again

# Troubleshooting

Symptom	Solution
Constraint processing is not applied by the printer driver when the Scan and Print operation is performed.	Constraint processing may not be applied depending on the specified settings.

---

***Using Local  
Setup Utility  
(LSU)***

---

**3**

---

# About Local Setup Utility (LSU)

By installing Local Setup Device (LSU) onto a computer connected to the machine, you can change machine settings and check the counters and machine status from the computer.

The following operations can be performed using LSU.

- Save speed dialing, group dialing and favorite information onto a computer
- Change speed dialing, group dialing and favorite information
- Print speed dialing, group dialing and favorite information specified with this utility.
- Check the counters

## LSU Operating Environment

The following environment is required in order to install LSU onto a computer.

Item	Operating environment
Operating system	Windows 2000 Server SP4 or later Windows XP for 32 bit/64bit Windows Server 2003 for 32 bit/64bit Windows Vista for 32 bit/64bit
Processor	Pentium II or faster
Memory	Memory capacity recommended for the operating system.  There should be enough memory for the operating system and the applications used.
Available hard disk space	100 MB or more
Web browser	Internet Explorer version 5.0 or later
Supported languages	English, French, German, Italian, Spanish, Portuguese, Russian, Czech, Slovak, Hungarian, Polish, Japanese, Korean, Simplified Chinese, Traditional Chinese



*Use a USB cable with an A-type connector (4-pin male) and a B-type connector (4-pin male). We recommend that the USB cable be no more than 3 meters (10 feet) long.*



*The printer driver for this machine and the TWAIN driver must be installed on the computer.*

## Installing LSU

- 1 Insert Applications CD/DVD in your CD/DVD-ROM drive.
- 2 Select the language.
- 3 From the Application Setup dialog, select “LSU”, and then click “Install”. The installer starts up.
- 4 Click the **Next** button, and then follow the on-screen instructions.

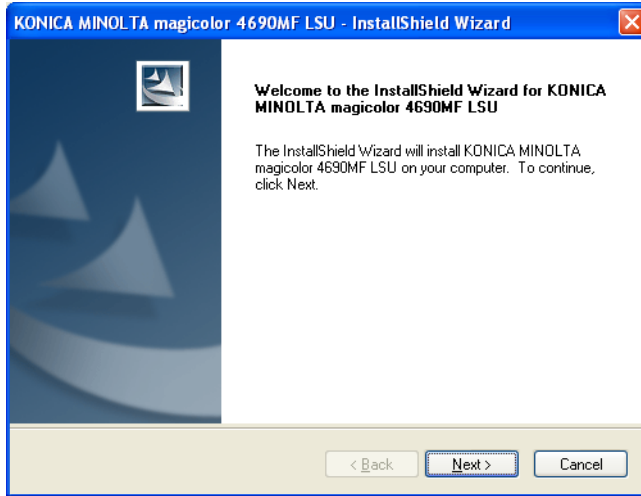

- 5 When a message appears, indicating that the installation of LSU is finished, click the **Finish** button.

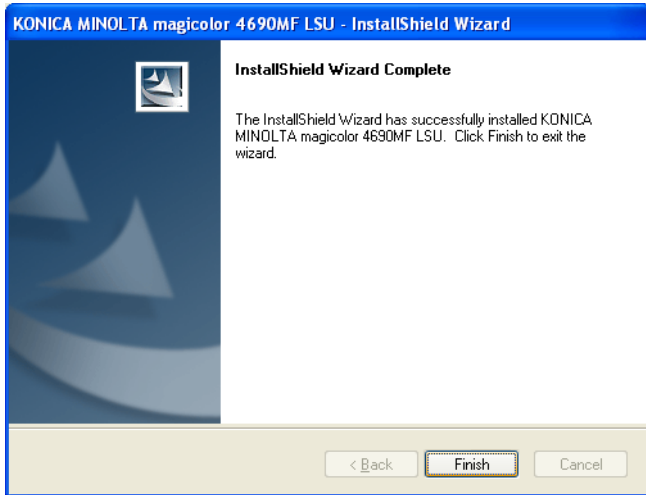

The installation of LSU is completed.

## Starting Up LSU

- 1 Click the Start button, point to "All Programs (Windows 2000: Programs)", "KONICA MINOLTA", "magicolor 4690MF", "LSU", and then click "KONICA MINOLTA magicolor 4690MF LSU".

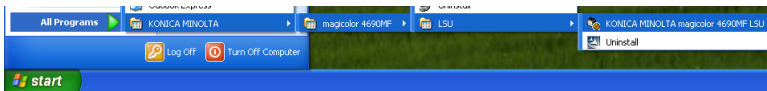

The main window of LSU appears.

# Main LSU Window

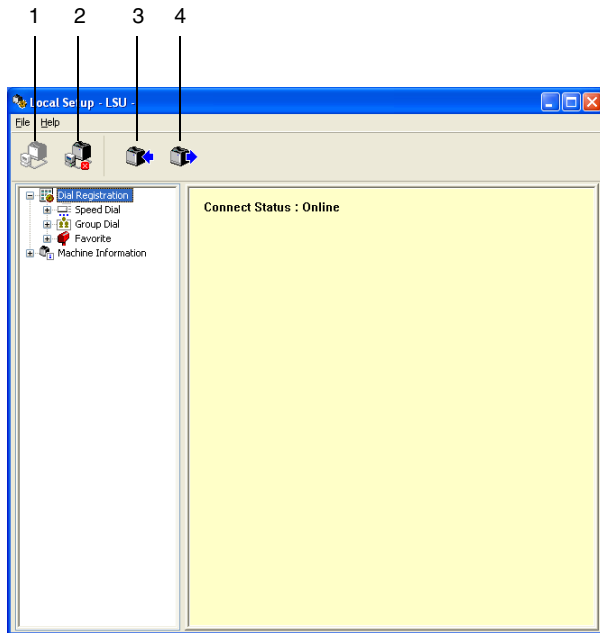

No.	Name	Description
1	Connect button	Click this button to connect the machine with the computer.
2	Disconnect button	Click this button to cut the connection between the machine and the computer.
3	Upload button	Click this button to send the settings file to the machine.
4	Download button	Click this button to send the machine's settings to the computer.

## Connecting to the Machine

1 Click .

When LSU is connected to the machine, "Connect Status: Online" appears.



*While operations are being performed in LSU, the machine cannot be operated from its control panel.*

## Downloading Information from the Machine

Click  to download information from the machine.

## Uploading Information to the Machine

Click  to send information to the machine.

## Dial Import/Dial Export

The items of speed dial, group dial, and favorite can be imported when “File” - “Dial Import” is specified from Menu. Those items can be exported when “File” - “Dial Export” is specified from Menu.



*The file is opened with the folder that is read or saved last time.*



*Do not import CSV files edited in Excel.*

# Registering Dialing Settings

This section provides descriptions on the settings that appear for speed dialing, group dialing, favorites and machine information.

## Programming a Speed Dial Number

- 1 Click **+** beside “Dial Registration”, and then click **+** beside the “Speed Dial”.
- 2 To register a fax or e-mail destination, click **+** beside “Fax/E-mail”. To register an FTP or SMB destination, click **+** beside “Scan To Server”.
- 3 From the tree that is displayed, click the speed dial number to be programmed, and then click **New Registration** button.

 *A maximum of 001-250 speed dial numbers can be programmed.*

 *The registered list can be switched over when **Speed Dial Setting** is changed.*

 *When “Fax/E-mail” or “Scan To Server” is selected, and **New Registration** button is selected, non registered number is automatically assign the speed dial number.*

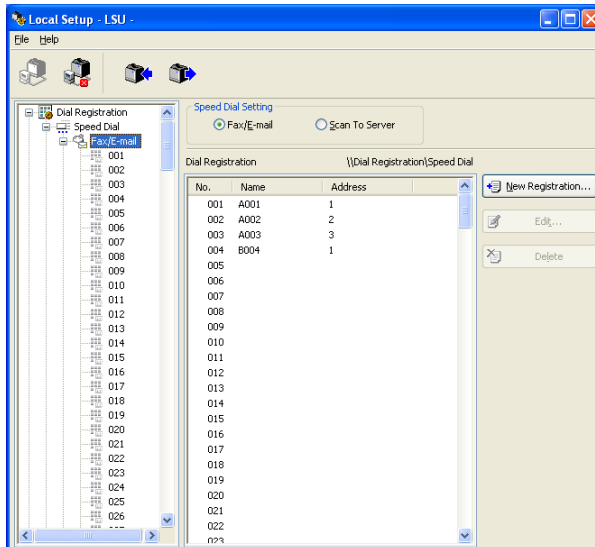

- 4 In the Register Speed Dial dialog box for the selected number, specify the desired settings.



To register a fax or e-mail destination, refer to “Adding a Speed Dial Number (Fax/E-mail)” on page 136.



To register an FTP or SMB destination, refer to “Adding a Speed Dial Number (Scan To Server)” on page 137.



Only numbers and letters can be typed in.

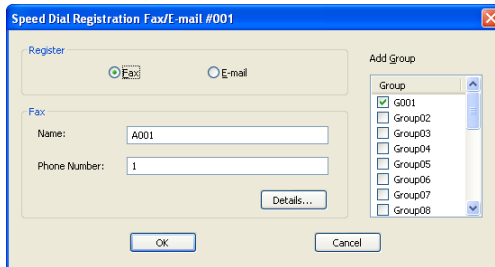

- 5 Click the **OK** button.  
Programming of the speed dial number is completed.

## Adding a Speed Dial Number (Fax/E-mail)

### For registering a fax number

- 1 Click the **New Registration** button.
- 2 Select “Fax”.
- 3 Specify the settings for the speed dialing.
  - A maximum of 20 characters can be entered for a name.
  - A maximum of 50 numbers can be entered for a fax number.
- 4 Click the **Details** button, and then specify the transmission speed and batch transmission time.
- 5 When registering speed dial numbers to a group, select from “Add Group” list.
  -  To edit a group dial, refer to “Programming/Editing a Group Dial” on page 139.
- 6 Click the **OK** button.  
The added speed dial number appears in the “Dial Registration” list.

## For registering an E-mail address

- 1 Click the **New Registration** button.
- 2 Select “E-mail”.
- 3 Specify the settings for the speed dialing.
  - A maximum of 20 characters can be entered for the name.
  - A maximum of 64 characters can be entered for the E-mail address.
- 4 When registering speed dial numbers to a group, select from “Add Group” list.  
 To edit a group dial, refer to “Programming/Editing a Group Dial” on page 139.
- 5 Click the **OK** button.  
The added speed dial number appears in the “Dial Registration” list.

## Adding a Speed Dial Number (Scan To Server)

### For FTP transmissions

- 1 Click the **New Registration** button.
- 2 Select “FTP”.

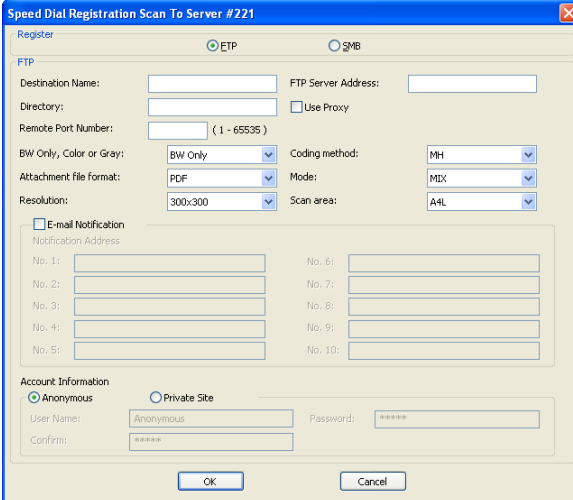

- 3 Specify the necessary information.
- 4 Click the **OK** button.  
The registered speed dial number appears in the “Dial Registration” list.

## For SMB transmissions

- 1 Click the **New Registration** button.
- 2 Select “SMB”.

Speed Dial Registration Scan To Server #221

Register

ETP  SMB

SMB

Destination Name:  Destination Address:

Directory:

BW Only, Color or Gray:  Coding method:

Attachment File format:  Mode:

Resolution:  Scan area:

E-mail Notification

Notification Address

No. 1:  No. 6:

No. 2:  No. 7:

No. 3:  No. 8:

No. 4:  No. 9:

No. 5:  No. 10:

Account Information

Anonymous  Private Site

User Name:  Password:

Confirm:

- 3 Specify the necessary information.
- 4 Click the **OK** button.  
The registered speed dial number appears in the “Dial Registration” list.

## Editing a Speed Dial Number

- 1 Select the speed dial number to be edited.
- 2 Click the **Edit** button.
- 3 In the Speed Dial Registration dialog box, edit the settings as desired.
- 4 Click the **OK** button to apply the changes.  
The edited speed dial number appears in the “Dial Registration” list.

## Deleting a Speed Dial Number

- 1 Select the speed dial number to be deleted.
- 2 Click the **Delete** button.  
The speed dial number is removed from the “Dial Registration” list.

## Programming/Editing a Group Dial



Program group dialing after programming speed dial numbers. Add or delete destinations from group dialing by changing the settings for the registered speed dial destinations. For details, refer to “Editing a Speed Dial Number” on page 138.

1 Click **+** beside “Dial Registration”, and then click **+** beside the “Group Dial”.

2 From the tree that is displayed, click the group name to be edited.



A maximum of 20 group dial can be programmed.



A maximum of 50 speed dial numbers can be programmed.



Click **+** beside the group name, and then displays the speed dial number that registered in the group.

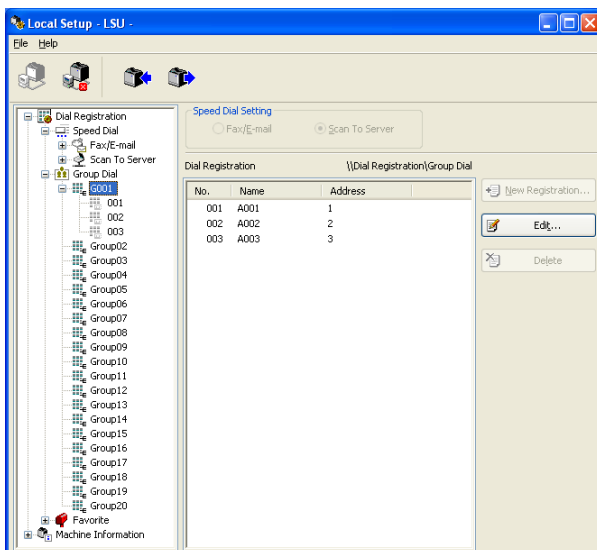

3 Click **Edit** button.



When selecting a speed dial number in the group, click **Edit** button, **Delete** button, and “Add to Group” is enabled. After clicking **Edit** or **Delete** button, the speed dial can be edited and deleted.

- 4 Specify the name of the group.

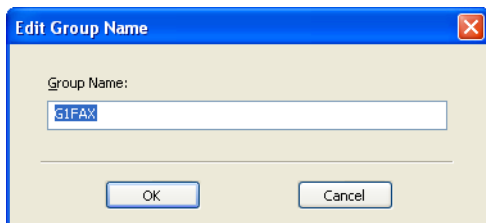

- 5 Click the **OK** button.  
Editing of the group name is completed.

## Registering to Favorites

This section provides details on registering speed dial numbers and group dial in the Favorite list.



*A maximum of 20 numbers can be registered to the favorite.*

- 1 Click **+** beside “Dial Registration”, and then click “Favorite”.
- 2 Click the **New Registration** button.

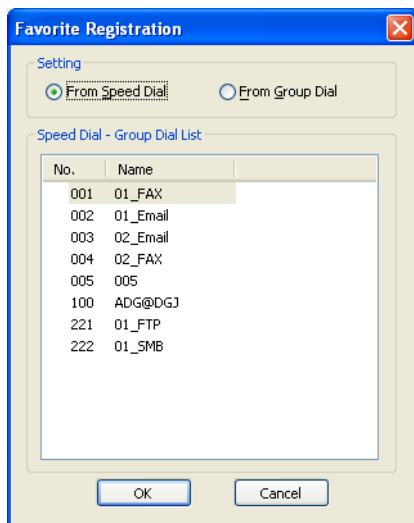

- 3 Click “From Speed Dial” or “From Group Dial”.  
The corresponding list of registered destinations appears.
- 4 From the tree, select the destination to be registered, and then click the **OK** button.  
The registered destination appears in the “Dial Registration” list.



To delete a destination from the Favorite list, select the desired destination, and then click the **Delete** button.

## Printing the List of Speed Dial, Group Dial and Favorite

The settings specified on the machine for speed dialing, group dialing and favorites can be printed.

- 1 Click "Print" on the "File" menu.
- 2 From the Select Print Item dialog box, select the list to be printed.
  - If "All" is selected, all items in the list are printed.
  - If "Select No." is selected, the number selected in the list is printed.

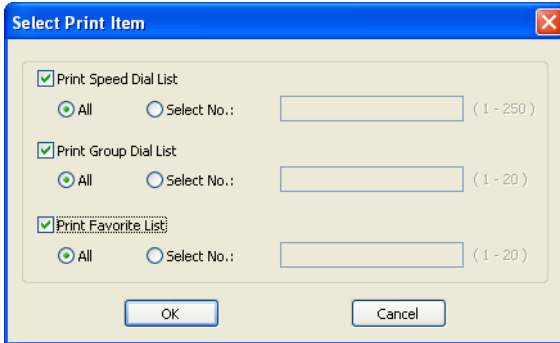

- 3 In the Print dialog box, click the **OK** button to begin printing.

## Displaying Machine Information

The settings downloaded from the machine or the settings saved in a read file can be displayed. These settings can be used to view the counters or check the machine information.

### Checking the Total Counter

- 1 On the “Machine Information” menu, click “Total Counter”.  
The Total Counter dialog box appears.

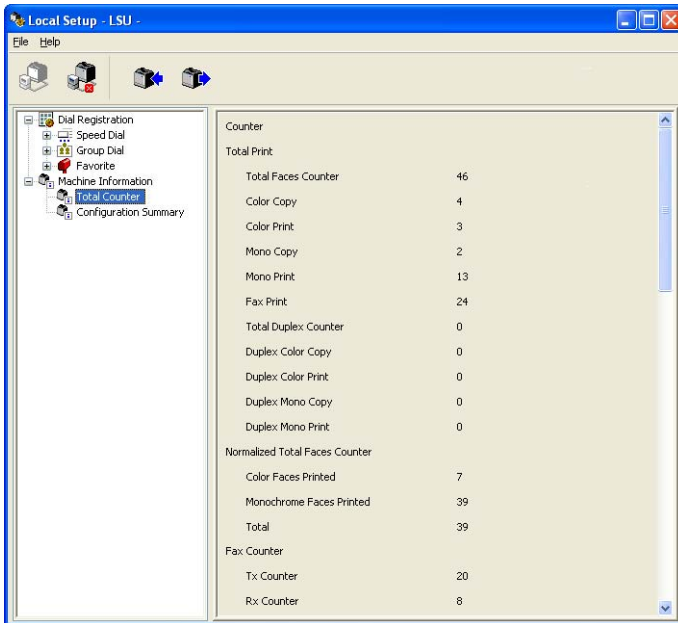

## Checking the Configuration Page

- 1 On the “Machine Information” menu, click “Configuration Summary”. The Configuration Summary dialog box appears.

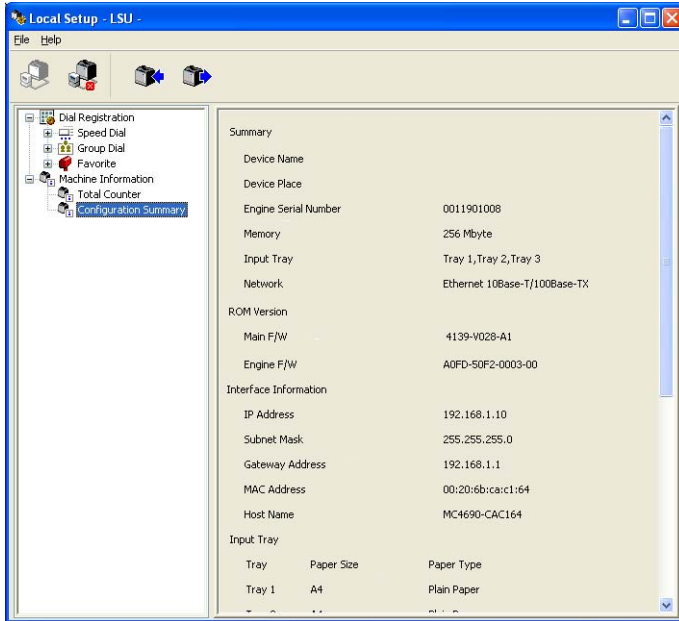

## Uninstalling LSU

- 1 Click the Start button, point to “All Programs (Windows 2000: Programs)”, “KONICA MINOLTA”, “magicolor 4690MF”, “LSU”, and then click “Uninstall”.
- 2 Follow the on-screen instructions.
- 3 When the following dialog box appears, the uninstallation is completed.

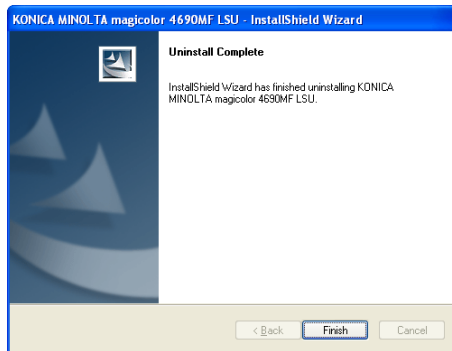

# Troubleshooting

Symptom	Solution
It takes a long time to access the printer driver when LSU has established a connection to the machine.	Wait until it can be accessed.

---

***Printer Utilities***

---

**4**

---

# Installing Printer Utilities on Windows



*You must have administrator privileges in order to install the Printer Utilities.*



*Before proceeding with the installation, be sure to exit all running applications.*

The following procedure describes how to install the Printer Utilities.

- Paper Port
  - PageScope Net Care
  - PageScope Network Setup
- 1 Insert the Applications CD/DVD in your CD/DVD-ROM drive.
  - 2 Select the language.
  - 3 Select the utilities to be installed.
  - 4 Follow the onscreen instructions to complete the installation.
  - 5 When the Information message box appears, select Finish.
  - 6 After the installation is complete, remove the Applications CD/DVD from your CD/DVD-ROM drive and store it in a safe place.

---

***Understanding  
the Network  
Configuration  
Menus***

---

**5**

---

# ADMIN. MANAGEMENT Menu

## Location within the Configuration Menu



The *ADMIN. MANAGEMENT* menu is accessible only by the administrator. To display the settings for this menu, press **▼** to display *UTILITY*, and press **select** key to display *MACHINE SETTING*, and then select *ADMIN. MANAGEMENT*, use the keypad to type in the 6-digits administrator access code, and then press the **Select** key.

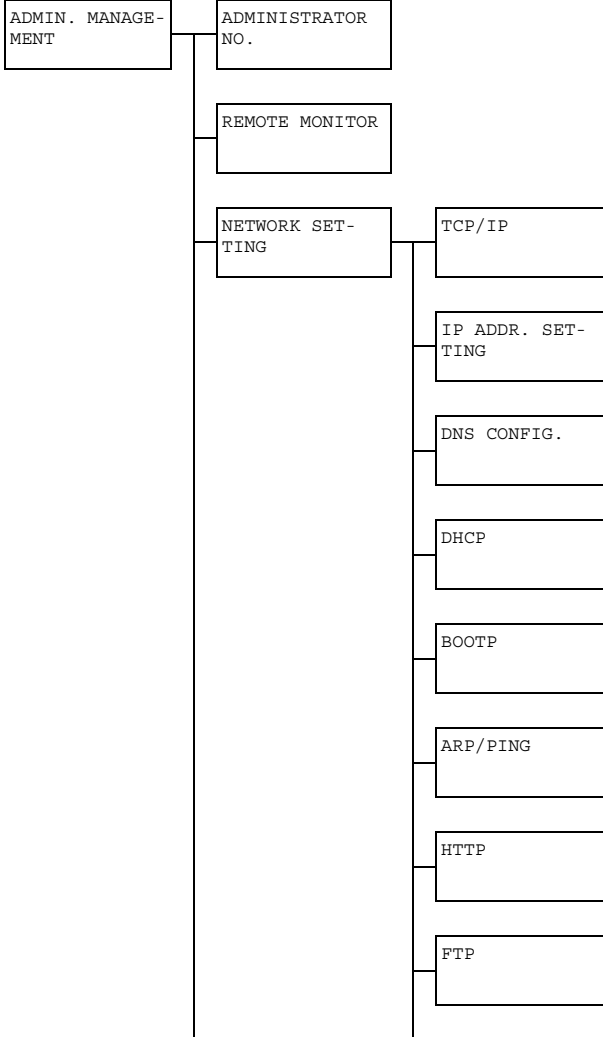

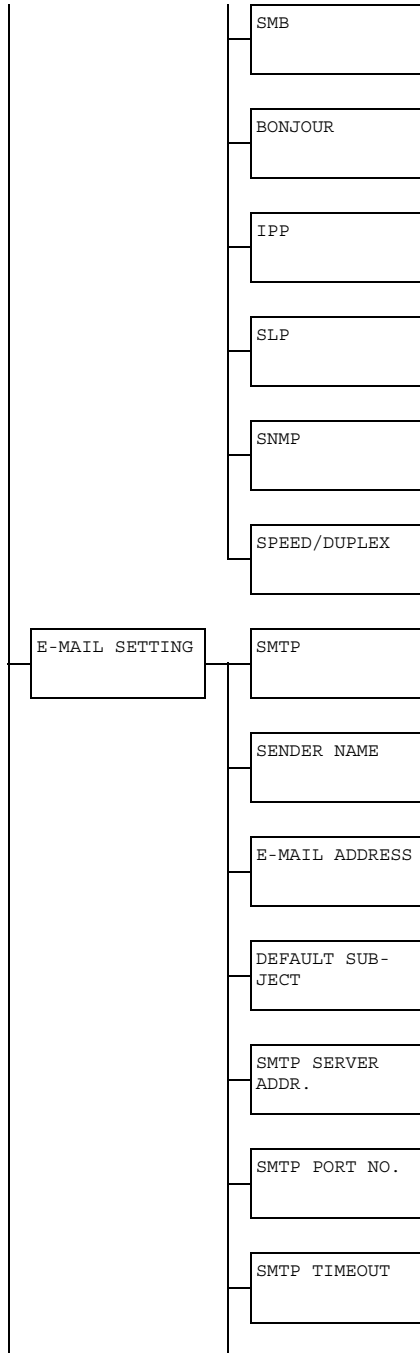

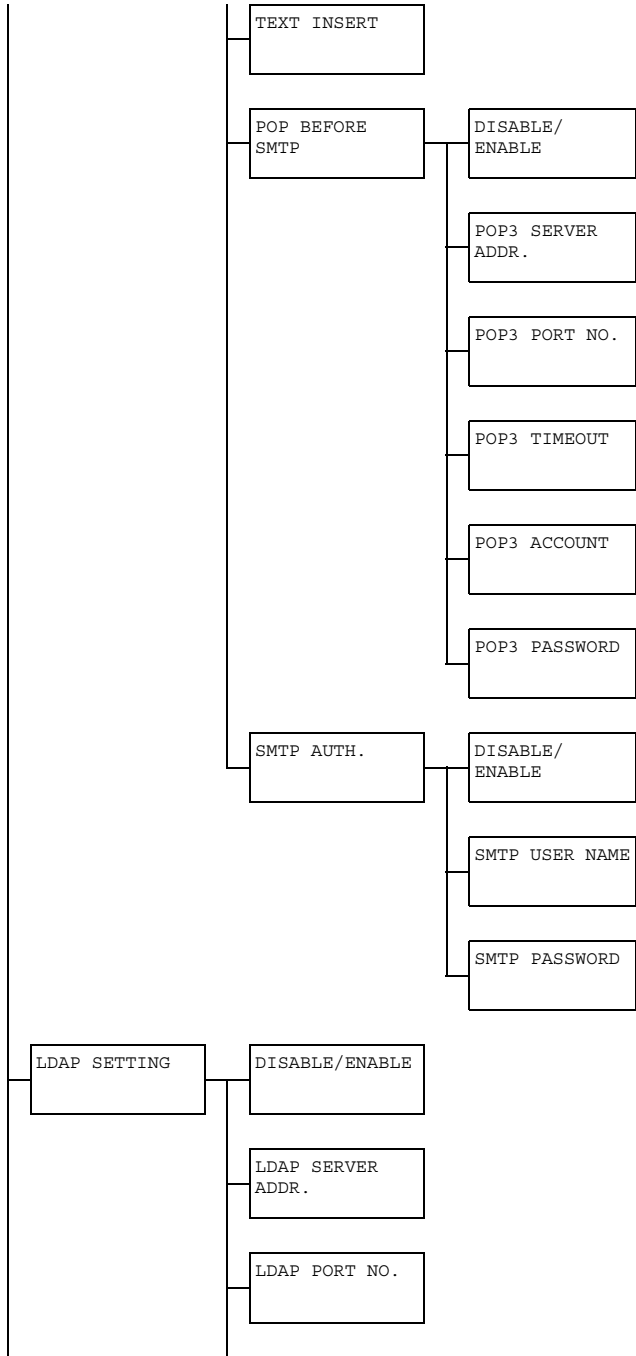

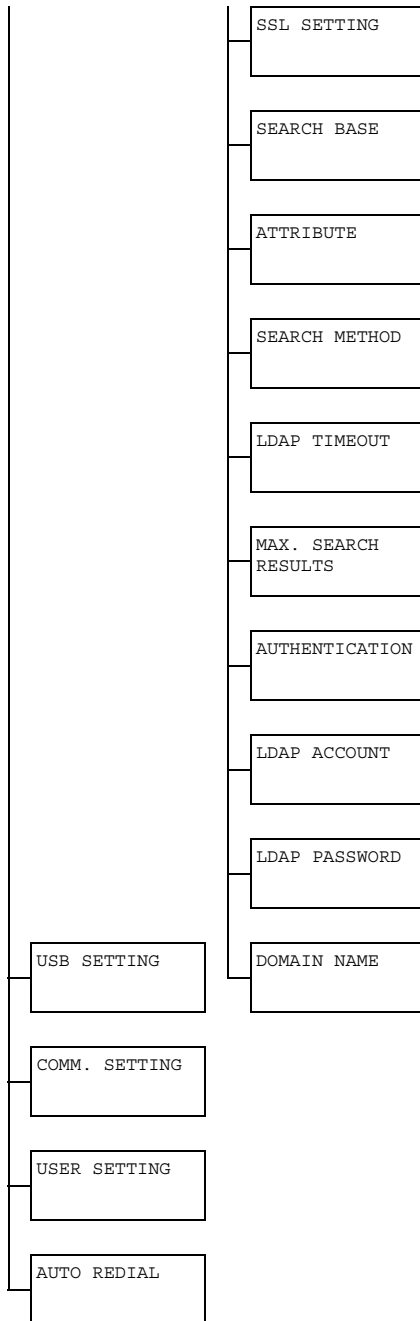







## Accessing the Network Setting Menu

Use the following series of keystrokes at the printer to access the Network Setting menu options on your printer. This menu provides access to all of the configurable network items.

<b>Press this key . . .</b>	(until) the message window reads . . .
	UTILITY
<b>Select</b> 	MACHINE SETTING
	ADMIN. MANAGEMENT
<b>Select</b> 	Use the keypad to input 6-digits administrator number.
<b>Select</b> 	ADMINISTRATOR NO.
	NETWORK SETTING

## Using the Network Setting Menu Options

If the printer is connected to a network, the following settings should be specified. For details about each setting, contact your network administrator.



To manually specify settings for the IP address, subnet mask and gateway, set *IP ADDR. SETTING* to *SPECIFY*.



When entering the IP address, do not enter a class D (between 224.0.0.0 and 239.255.255.255) or class E (between 240.0.0.0 and 255.255.255.255) IP address.  
In addition, "255" cannot be entered as the last three digits of the IP address.

### TCP/IP

<b>Purpose</b>	Enables or disables TCP/IP.  If ENABLE is selected, TCP/IP is enabled.  If DISABLE is selected, TCP/IP is disabled.
<b>Options</b>	DISABLE/ENABLE
<b>Default</b>	ENABLE

## IP ADDR. SETTING

<b>Purpose</b>	<p>Sets the IP address of this printer on the network.</p> <p>Sets the subnet mask of the network. The subnet mask allows you to limit access to your printer (for example, according to departmental divisions).</p> <p>Sets the address of the router/gateway when a router/gateway is used on your network and you allow users outside your network environment to print on your printer.</p>
<b>Options</b>	AUTO/SPECIFY
<b>Default</b>	AUTO  (If IP ADDR. SETTING is set to SPECIFY) IP ADDRESS: 0.0.0.0 SUBNET MASK: 255.255.255.0 GATEWAY: 0.0.0.0
<b>Range</b>	(If IP ADDR. SETTING is set to SPECIFY) 0-255 for each xxx triplet  Use the keypad to input each number; use the Left and Right keys to move between triplets.
<b>Notes</b>	<p>A single digit number, such as "1", cannot be input as "001". Align the number on the left and input "1" as "1 _ _". Use the ◀ and ▶ keys to move between triplets.</p> <p>The <b>Back</b> key can also be used for deleting. To cancel IP Address menu, hold down the <b>Back</b> key for more than one second, and then press the <b>Back</b> key again after all settings have been cleared.</p> <p>After changing the settings, the printer must be turned off, then on again.</p>

## DNS CONFIG.

<b>Purpose</b>	Sets whether or not the DNS server setting is to be specified. If specifying the DNS server setting, the SMTP server can be specified as a host name when using network scanning. If <b>ENABLE</b> is selected, type in the IP address of the DNS server. If <b>DISABLE</b> is selected, the DNS server cannot be referenced.
<b>Options</b>	DISABLE/ENABLE
<b>Default</b>	DISABLE
<b>Range</b>	(If <b>DNS CONFIG.</b> is set to <b>ENABLE</b> ) 0-255 for each xxx triplet  Use the keypad to input each number; use the Left and Right keys to move between triplets.
<b>Notes</b>	A single digit number, such as “1”, cannot be input as “001”. Align the number on the left and input “1” as “1 __”. Use the ◀ and ▶ keys to move between triplets.  The <b>Back</b> key can also be used for deleting. To cancel <b>DNS CONFIG.</b> menu, hold down the <b>Back</b> key for more than one second, and then press the <b>Back</b> key again after all settings have been cleared.  After changing the settings, the printer must be turned off, then on again.



*When using network scanning and when specifying the SMTP server as a host name instead of as an IP address, be sure to select **ENABLE**, and then specify the IP address of the DNS server.*

## DHCP

<b>Purpose</b>	If there is a DHCP server on the network, specifies whether the IP address and other network information is automatically assigned by the DHCP server.
<b>Options</b>	DISABLE/ENABLE
<b>Default</b>	ENABLE

## BOOTP

<b>Purpose</b>	If there is a BOOTP server on the network, specifies whether the IP address and other network information is automatically assigned by the BOOTP server.
<b>Options</b>	DISABLE/ENABLE
<b>Default</b>	DISABLE

## ARP/PING

<b>Purpose</b>	Specify whether the IP address is automatically assigned and network information is confirmed by ARP/PING command.
<b>Options</b>	DISABLE/ENABLE
<b>Default</b>	DISABLE

## HTTP

<b>Purpose</b>	Select whether or not to enable HTTP. If ENABLE is selected, HTTP is enabled. If DISABLE is selected, HTTP is disabled.
<b>Options</b>	DISABLE/ENABLE
<b>Default</b>	ENABLE

## FTP

<b>Purpose</b>	Select whether or not to enable FTP. If <b>ENABLE</b> is selected, FTP is enabled. If <b>DISABLE</b> is selected, FTP is disabled.
<b>Options</b>	DISABLE/ENABLE
<b>Default</b>	ENABLE

## SMB

<b>Purpose</b>	Select whether or not to enable SMB. If <b>ENABLE</b> is selected, SMB is enabled. If <b>DISABLE</b> is selected, SMB is disabled.
<b>Options</b>	DISABLE/ENABLE
<b>Default</b>	ENABLE

## BONJOUR

<b>Purpose</b>	Select whether or not to enable Bonjour. If <b>ENABLE</b> is selected, Bonjour is enabled. If <b>DISABLE</b> is selected, Bonjour is disabled.
<b>Options</b>	DISABLE/ENABLE
<b>Default</b>	ENABLE

## IPP

<b>Purpose</b>	Select whether or not to enable IPP. If <b>ENABLE</b> is selected, IPP is enabled. If <b>DISABLE</b> is selected, IPP is disabled.
<b>Options</b>	DISABLE/ENABLE
<b>Default</b>	ENABLE

## SLP

<b>Purpose</b>	Select whether or not to enable SLP. If <b>ENABLE</b> is selected, SLP is enabled. If <b>DISABLE</b> is selected, SLP is disabled.
<b>Options</b>	DISABLE/ENABLE
<b>Default</b>	ENABLE

## SNMP

<b>Purpose</b>	Select whether or not to enable SNMP. If <b>ENABLE</b> is selected, SNMP is enabled. If <b>DISABLE</b> is selected, SNMP is disabled.
<b>Options</b>	DISABLE/ENABLE
<b>Default</b>	ENABLE

## SPEED/DUPLEX

<b>Purpose</b>	Specifies the transmission speed for the network and the transmission method for bi-directional transmission.
<b>Options</b>	AUTO 10BASE-T FULL 10BASE-T HALF 100BASE-TX FULL 100BASE-TX HALF
<b>Default</b>	AUTO



---

***Network Printing***

---

**6**

---

# Network Connection

## Theory

To connect your printer in a TCP/IP network environment, you must make sure that the internal network addresses in the printer have been set.



*In many cases, you have to enter only a unique IP address. However, you may also have to enter a subnet mask and/or a gateway (router) address, depending on your network configuration requirements.*

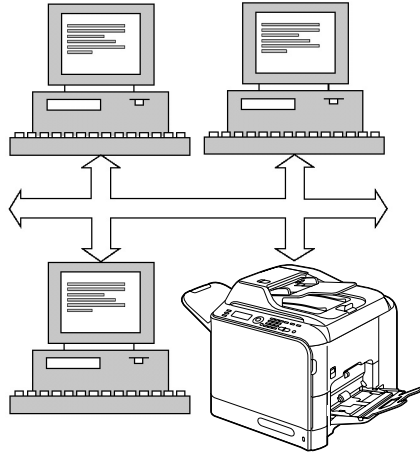

# Making the Connection

## Ethernet Interface

An RJ45 connector can be used as the Ethernet interface for this printer.

When connecting your printer to an Ethernet network, the tasks you perform depend on how you plan to set the printer's IP (Internet Protocol) address.

- **IP Address**—A unique identifier for each device on a TCP/IP network.
- **Subnet Mask**—A filter used to determine what subnet an IP address belongs to.
- **Gateway**—A node on a network that serves as an entrance to another network.

Since the IP address for each PC and printer on your network must be unique, you usually need to modify this preset address so it doesn't conflict with any other IP address or your network or any attached network. You can do this in one of two ways. Each is explained in detail in the following sections.

- Using DHCP
- Setting the address manually

## Using DHCP

If your network supports DHCP (Dynamic Host Configuration Protocol), the printer's IP address will be automatically assigned by the DHCP server when you turn on the printer. (Refer to "Network Printing" on page 166 for a description of DHCP.)



*If the IP address of the printer is not set automatically, check if the printer has been set to allow DHCP to be used (REPORT/STATUS — REPORT — CONFIGURATION PAGE). If the printer has been set so that DHCP cannot be used, select AUTO in the UTILITY — ADMIN. MANAGEMENT — NETWORK SETTING — IP ADDR. SETTING menu.*

- 1 Connect your printer to the network.  
*When using an Ethernet cable, plug the RJ45 connector into the Ethernet interface port of the printer.*
- 2 Turn on your PC and printer.
- 3 After the printer's message window is initialized, install the printer driver.

## Setting the Address Manually

You may also manually change the printer's IP address, subnet mask, and gateway by using the following instructions. (See chapter 5, "Understanding the Network Configuration Menus," for more information.)



*When the IP address is changed, add a new port or reinstall the printer driver.*



### CAUTION

**You should always notify your network's administrator before changing the printer's IP address.**

- 1 Turn on your PC and printer.
- 2 After the machine's message window is initialized, set the IP address.

Press this key . . .	(until) the message window displays . . .
▼	UTILITY
Select ↵	MACHINE SETTING
▼	ADMIN. MANAGEMENT
Select ↵	Use the keypad to input 6-digits administrator number.
Select ↵	ADMINISTRATOR NO.
▼	NETWORK SETTING
Select ↵	TCP/IP
▼	IP ADDR. SETTING
Select ↵	▶ AUTO SPECIFY
▼	AUTO ▶ SPECIFY
Select ↵	IP ADDRESS : 0 . 0 . 0 . 0

Use the keypad to input each number.  
 A single digit number, such as “1”, cannot be input as “001”. Align the number on the left and input “1” as “1 \_\_”. Use the ◀ and ▶ keys to move between triplets.  
 The **Back** key can also be used for deleting. To cancel IP Address menu, hold down the **Back** key for more than one second, and then press the **Back** key again after all settings have been cleared.

<b>Select</b> ←	SUBNET MASK : 255 . 255 . 255 . 0
--------------------	--------------------------------------

Use the keypad to input each number.  
 A single digit number, such as “1”, cannot be input as “001”. Align the number on the left and input “1” as “1 \_\_”. Use the ◀ and ▶ keys to move between triplets.  
 The **Back** key can also be used for deleting. To cancel Subnet Mask menu, hold down the **Back** key for more than one second, and then press the **Back** key again after all settings have been cleared.

<b>Select</b> ←	GATEWAY : 0 . 0 . 0 . 0
--------------------	----------------------------

Use the keypad to input each number.  
 A single digit number, such as “1”, cannot be input as “001”. Align the number on the left and input “1” as “1 \_\_”. Use the ◀ and ▶ keys to move between triplets.  
 The **Back** key can also be used for deleting. To cancel Gateway menu, hold down the **Back** key for more than one second, and then press the **Back** key again after all settings have been cleared.

<b>Select</b> ←	IP ADDR. SETTING
--------------------	------------------

- 3 Restart the printer.
- 4 Print a configuration page to verify that the correct IP address, subnet mask, and gateway have been set.
- 5 After the printer's message window is initialized, install the printer driver.

# Network Printing

Network printing terms are described below:

- Bonjour
- BOOTP
- DHCP
- DNS
- FTP
- HTTP
- IPP
- LDAP
- LPD/LPR
- POP Before SMTP
- Port 9100
- SLP
- SMB
- SMTP
- SMTP Authentication
- SNMP
- TCP/IP

This section contains descriptions of these network printing terms.

## Bonjour

Macintosh network technology for automatically detecting devices connected to the network and for specifying settings. Previously called “Rendezvous”, the name was changed to “Bonjour” starting with Mac OS X v10.4.

## BOOTP

BOOTP (Bootstrap Protocol) is an Internet protocol that enables a diskless workstation to discover (1) its own IP address, (2) the IP address of a BOOTP server on the network, and (3) a file that can be loaded into memory to boot the workstation. This enables the workstation to boot without requiring a hard or floppy disk drive.

## **DHCP**

DHCP (Dynamic Host Configuration Protocol) is a protocol for assigning dynamic IP addresses to devices on a network. With dynamic addressing, a device can have a different IP address every time it connects to the network. In some systems, the device's IP address can even change while it is still connected. DHCP also supports a mix of static and dynamic IP addresses. Dynamic addressing simplifies network administration because the software keeps track of IP addresses rather than requiring an administrator to manage the task. This means that a new computer can be added to a network without the hassle of manually assigning it a unique IP address.

## **DNS**

Abbreviation for Domain Name System. A system that acquires the supported IP addresses from host names in a network environment. DNS allows the user to access other computers over a network by specifying host names, instead of difficult to memorize and understand IP addresses.

## **FTP**

Abbreviation for File Transfer Protocol. A protocol for transferring files over the Internet or an intranet on the TCP/IP network.

## **HTTP**

HTTP (HyperText Transfer Protocol) is the underlying protocol used by the World Wide Web. It defines how messages are formatted and transmitted, and what actions web servers and browsers should take in response to various commands. For example, when you enter a URL in your browser, this actually sends an HTTP command to the Web server directing it to fetch and transmit the requested web page.

## **IPP**

IPP (Internet Printing Protocol) is a protocol for end users' most common printing situations over the Internet. It allows users to find out about a printer's capabilities, submit print jobs to a printer, determine the status of the printer or print job, and cancel a previously submitted print job.

For more information on using IPP, See "Printing via IPP (Internet Printing Protocol) – Windows Server 2003/XP/2000" on page 171.

## **LDAP**

On a TCP/ IP network, such as the Internet or an intranet, LDAP (Lightweight Directory Access Protocol) is a protocol that is used to access a database for managing environment information and the e-mail addresses of network users.

## **LPD/LPR**

LPD/LPR (Line Printer Daemon/Line Printer Request) is a platform-independent printing protocol that runs over TCP/IP. Originally implemented for BSD UNIX, its use has spread into the desktop world and is now an industry standard.

## **POP Before SMTP**

A user authentication method for sending E-mail messages. First, the reception operation is performed and the user is authenticated by the POP server. Then, IP addresses where the user was successfully authenticated by the POP server are permitted to use the SMTP server. This method prevents third parties without permission to use the mail server from sending mail messages.

## **Port 9100**

When printing through a network, TCP/IP port number 9100 can be used to send raw data.

## **SLP**

Traditionally, in order to locate services on the network, users had to supply the host name or network address of the machine providing the desired service. This has created many administrative problems.

However, SLP (Service Location Protocol) simplifies the discovery and use of network resources such as printers by automating a number of network services. It provides a framework that allows networking applications to discover the existence, location, and configuration of networked services.

With SLP users no longer need to know the names of network hosts. Instead, they need to know only the description of the service they are interested in. Based on this description, SLP is able to return the URL of the desired service.

## **Unicast, Multicast, and Broadcast**

SLP is a unicast and a multicast protocol. This means that messages can be sent to one agent at a time (unicast) or to all agents (that are listening) at the same time (multicast). However, a multicast is not a broadcast. In theory, broadcast messages are “heard” by every node on the network. Multicast differs from broadcast because multicast messages are only “heard” by the nodes on the network that have “joined the multicast group.”

For obvious reasons network routers filter almost all broadcast traffic. This means that broadcasts that are generated on one subnet will not be “routed” or forwarded to any of the other subnets connected to the router (from the router’s perspective, a subnet is all machines connected to one of its ports). Multicasts, on the other hand, are forwarded by routers. Multicast traffic from a given group is forwarded by routers to all subnets that have at least one machine that is interested in receiving the multicast for that group.

## **SMB**

SMB (Server Message Block) is a protocol for sharing network resources, such as files and printers, in a Windows environment. If the Samba server software is used on Linux or UNIX, services using SMB can be shared.

## **SMTP**

SMTP (Simple Mail Transfer Protocol) is a protocol for sending E-mail.

This protocol was originally used to send E-mail between servers; This protocol was originally used to send E-mail between servers; however, currently it is also used by client E-mail software that uses POP to send E-mail to servers.

## **SMTP Authentication**

Specification that adds user authentication functions to SMTP, which is used for sending E-mail.

When sending E-mail, authentication of the user is performed by the SMTP server, and the E-mail message is permitted to be sent only if authentication was successful.

## **SNMP**

SNMP (Simple Network Management Protocol) is actually a set of protocols for managing complex networks. SNMP works by sending messages to different parts of a network. SNMP-compliant devices, called agents, store data about themselves in Management Information Bases (MIBs) and return this data to the SNMP requesters.

## TCP/IP

Most networks combine TCP (Transmission Control Protocol) with the lower-level protocol IP (Internet Protocol). TCP establishes a virtual connection between two host systems and guarantees the delivery of data between them while IP specifies the format and addressing of this data sent between these two host systems.

# Printing via IPP (Internet Printing Protocol) – Windows Server 2003/XP/2000

## Adding an IPP Port using Add Printer Wizard

- For Windows Server 2003/XP: Click **Start**, select **Printers and Faxes**, and then click **Add Printer**.
  - For Windows 2000: Click **Start**, point to **Settings**, click **Printers**, and then click **Add Printer**.
- 1 In the second dialog box select the **Network Printer** radio button and then choose **Next**.

### Windows Server 2003/XP

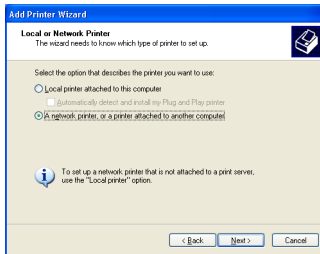

### Windows 2000

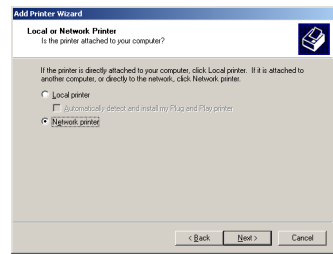

- 2 In the URL field in the next dialog box enter the printer's network path-name in one of the following formats and then choose **Next**:

- `http://ipaddress/ipp`
- `http://ipaddress:80/ipp`
- `http://ipaddress:631/ipp`

### Windows Server 2003/XP

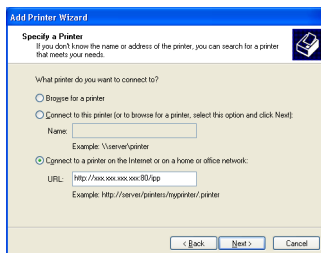

### Windows 2000

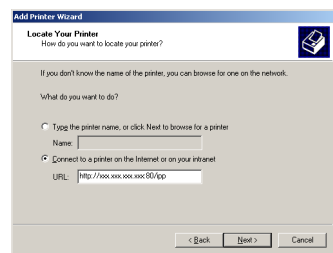

If your system cannot connect to the printer, the following message appears:

- **Windows Server 2003/XP**—“Windows cannot connect to the printer. Either the printer name was typed incorrectly, or the specified printer has lost its connection to the server. For more information, click **Help**.”
- **Windows 2000**—“Could not connect to the printer. You either entered a printer name that was incorrect or the specified printer is no longer connected to the server. Click **Help** for more information.”

**3 Windows Server 2003/XP**—Go to step 4.

**Windows 2000**—If you entered a valid path in the previous step, the following message displays: “The server on which the KONICA MINOLTA magicolor 4690MF printer resides does not have the correct printer driver installed. If you want to install the driver on your local computer, click **OK**.” The reason for this is that you do not yet have a printer driver installed. Choose **OK**.

**4** Choose **Have Disk**, locate the directory on the CD/DVD where the printer driver files are located (for example: Printer Driver\English\Win32), and then choose **OK**.

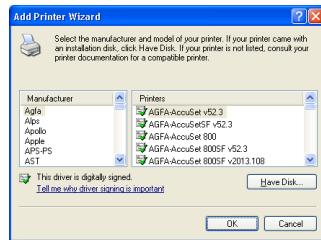

**5** Finish installing the printer driver.

# Printing via IPP (Internet Printing Protocol) - Windows Vista

## Adding an IPP Port using Add Printer Wizard

- 1 Click **Start**, click **Control Panel**, and then click **Printers**.
- 2 Click **Add a printer**.
- 3 In the dialog box click **Add a network, wireless or Bluetooth printer**.

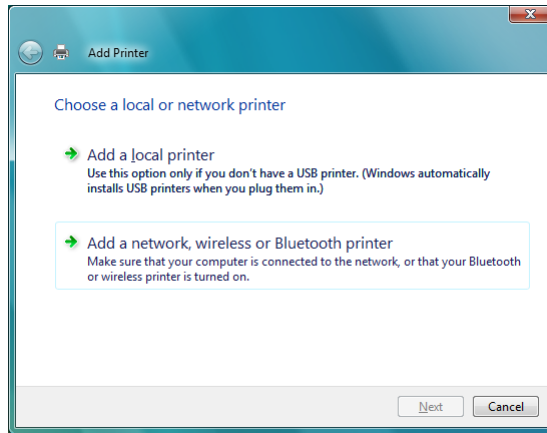

- 4 In the dialog box, click **The printer that I want isn't listed**.

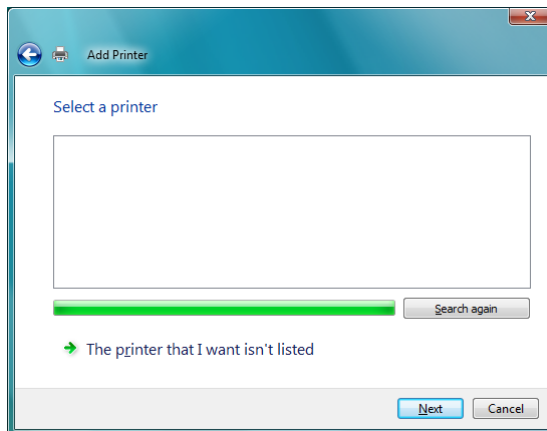

5 In the URL field in the next dialog box enter the printer's network path-name in one of the following formats and then choose **Next**:

- http://ipaddress/ipp
- http://ipaddress:80/ipp
- http://ipaddress:631/ipp

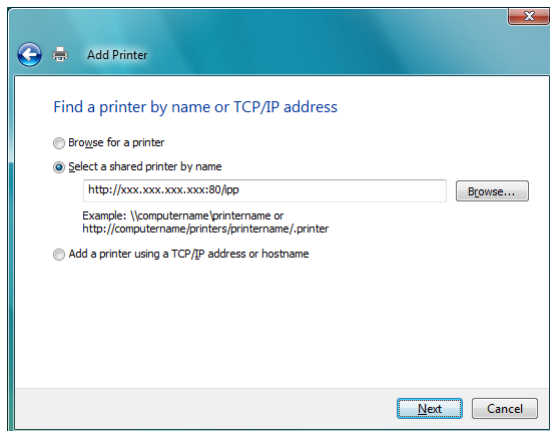

- Windows cannot connect to the printer. Make sure that you have typed the name correctly, and that the printer is connected to network.

6 Choose **Have Disk**, locate the directory on the CD/DVD where the printer driver files are located (for example: Printer Driver\English\Win32), and then choose **Next**.



7 Finish installing the printer driver.

---

***Using PageScope  
Web Connection***

---

**7**

---

# About PageScope Web Connection

This chapter provides information on PageScope Web Connection, an HTTP (HyperText Transfer Protocol)-based web page that resides in your printer and that you can access using your Web browser.

This page gives you instant access to printer status and the most frequently used printer configuration options. Anyone on your network can access the printer using their web browser software. In addition, with the proper password, you can change the configuration of the printer without leaving your PC.

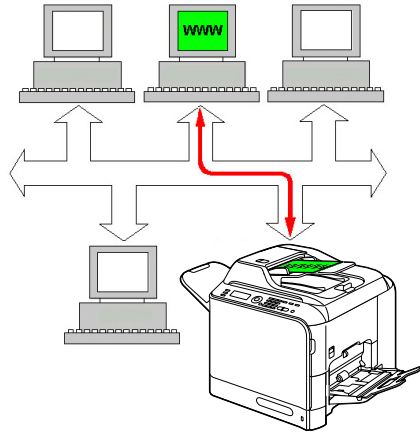

*Users who are not given passwords by the administrator can still view the configuration settings and options but are not able to save or apply changes.*

## Requirements

To use PageScope Web Connection, the following is required:

- Windows Server 2003/XP/2000/Windows Vista, Mac OS X10.2 or later
- Microsoft Internet Explorer version 6 or later
- Safari version 2.0 or later



*You do not need an Internet connection.*

- TCP/IP communication software (used by PageScope Web Connection) installed on your PC
- A network, to which both your PC and the printer are connected



*You cannot access PageScope Web Connection using a local (USB) connection.*

# Setting Up the Printer Web Page

Setting up the printer web page to run on your network involves two basic steps:

- Determining the name or address of your printer
- Setting up the “no proxy” preferences in your browser software

## Determining the Printer Name

The printer web page can be accessed in two ways:



*The printer names can also be determined via WINS if the network supports it.*

- Through the assigned name of the printer—This name comes from the IP host table (the filename is **hosts**) on the computer system and is usually assigned by the system administrator (for example, magicolor 4690MF). It may be more convenient for you to use the printer name than the IP address.

### **Location of the Host Table on the PC**

- Windows Server 2003/XP/Vista  
windows\system32\drivers\etc\hosts
- Windows 2000  
winnt\system32\drivers\etc\hosts
- Through the printer’s IP address—The IP address of your printer is a unique number and, therefore, may be the preferred identification to enter, especially if you have more printers active in your network. The printer’s IP address is listed on the configuration page.

## Setting Up Your Browser Software

Since your printer resides on your intranet and is not accessible beyond the firewall of your network, you must set up the proper “preferences” in your browser software. Your printer name or IP address must be added to the “no proxy” list in the preferences dialog box of the browser.



*You need to do this procedure only once.*

The sample screens below may be different from yours depending on software versions and operating systems in use.



*Our examples represent the IP address of the printer with xxx.xxx.xxx.xxx. Always enter your printer’s IP address without leading zeros. For example, 192.168.001.002 should be entered as 192.168.1.2.*

## Internet Explorer (version 6.0 for Windows)

- 1 Start Internet Explorer.
- 2 From the **Tools** menu choose **Internet Options**.
- 3 Select the **Connections** tab on the dialog box.
- 4 Choose the **LAN Settings** button to display the Local Area Network (LAN) Settings dialog box.
- 5 Select **Advanced** in Proxy server to open the Proxy Settings dialog box.
- 6 In the **Exceptions** text box, type a comma after the last entry and then type the printer name or the IP address of your printer.
- 7 Choose **OK** three times to return to the main browser window.
- 8 Enter the printer's IP address in the URL Address box to access the printer home page.

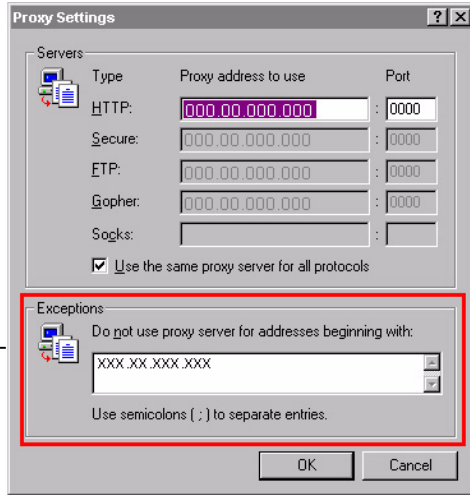

Address  http://192.168.1.2/

## Safari (version 2.0)

- 1 From the **Apple** menu, choose **Location**, and then click **Network preferences**.
- 2 Click **Configure** in the Network preferences dialog box.
- 3 Click the **Proxies** tab.
- 4 In the **Bypass proxy settings for these Hosts & Domains** list, type in the name or IP address of the printer.
- 5 Click **Apply Now**.
- 6 In the URL address bar, type in the name or IP address of the printer to access the printer's Web page.

# Understanding the PageScope Web Connection Window

The illustration below identifies the navigation and configuration areas of the windows that you see in PageScope Web Connection windows.

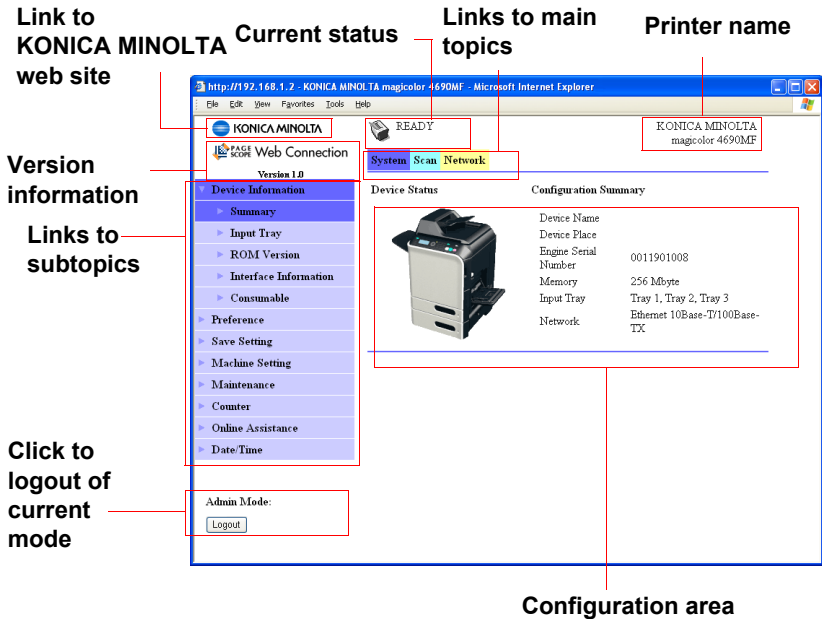

## Navigation

Selecting the main topic and subtopic displays the configuration area for the printer options (parameters) associated with your selections.





To change a current setting, click on the current setting and then select from the available choices or enter the new value.



*In order to apply or save any changes made to the configuration settings, PageScope Web Connection must be logged in from Administrator Mode. (For details, refer to "Administrator Mode" on page 180.)*

## Current Status

The current status of the printer is displayed at the top of all PageScope Web Connection windows. The icon displays the type of status being displayed.

Icon	Status	Description	Examples
	Ready	The printer is online and either ready to print or printing.	READY PRINTING
	Warning	The printer needs attention, but printing continues.	PLEASE WAIT WARMING UP
	Error	The printer needs attention before printing can resume.	FUSER JAM FRONT COVER OPEN
	Fatal Error	The printer must be rebooted. If that doesn't fix the error, service is required.	MACHINE TROUBLE SERVICE CALL

## User Mode

You automatically enter User Mode whenever you enter PageScope Web Connection. In User Mode you can view configuration settings but not change them.

## Administrator Mode

In order to change any configuration settings through PageScope Web Connection, you must first enter Administrator Mode:

- 1 Type the password in the **Admin Password** text box.



*The default password is "sysadm". However, once you are in Administrator Mode, you can change this in the **System - Preference** window.*

- 2 Choose the **Login** button.



*If you type an incorrect password, the following message displays: "Invalid Password." Retype the password.*

# Configuring the Machine for User Mode

You automatically enter User Mode whenever you enter PageScope Web Connection. In User Mode, you can view configuration settings but not change them.

## System Page

This page allows you to view several user and printer specific item.

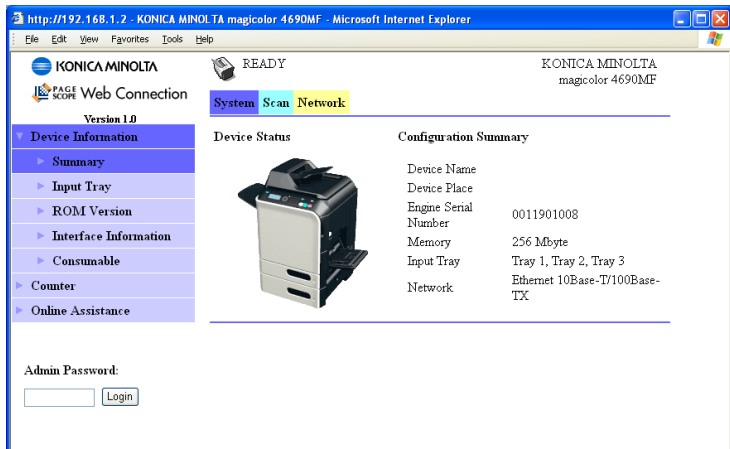

## Device Information

### Summary (shown above)

The **System - Device Information - Summary** window provides the following information.

Item	Description
Printer name/status	Shows the name assigned to your machine, and displays the current status of the machine—just as it's displayed on the machine's control panel message window.
Device Status (Product image)	Identifies the type of machine that you are browsing. The machine is pictured in the illustration with all installed options.
Device Name	Displays the name of the machine.
Device Place	Displays the setup location for the machine.
Engine Serial Number	Displays the serial number of the machine engine.

Item	Description
Memory	Displays the amount of memory installed in the machine.
Input Tray	Identifies whether an optional lower feeder unit is “Tray 1, Tray 2” or “Tray 1, Tray 2, Tray 3”.
Network	Lists the machine interface (Ethernet 10Base-T/ 100Base-TX)
Login button	Logs in of Administrator Mode.   <i>This button is available from all web pages (User Mode).</i>

## Input Tray

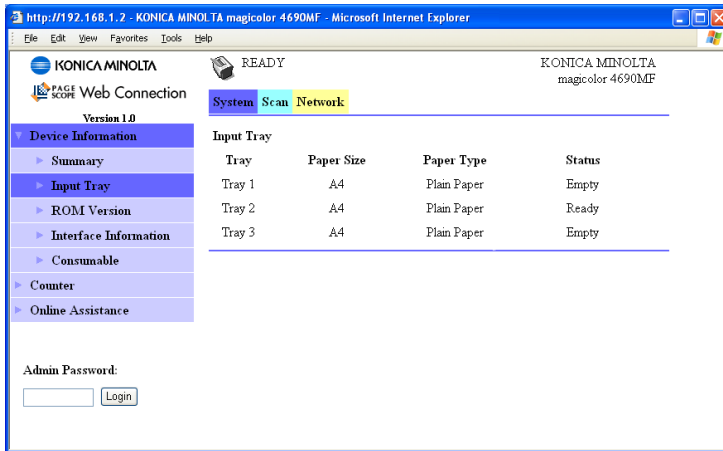

The screenshot shows the 'Input Tray' configuration page in the Konica Minolta web interface. The page title is 'READY' and the device model is 'KONICA MINOLTA magicolor 4690MF'. The navigation menu includes 'System', 'Scan', and 'Network', with 'System' selected. The 'Device Information' section is expanded to show 'Input Tray'. The table below shows the status of three trays:

Tray	Paper Size	Paper Type	Status
Tray 1	A4	Plain Paper	Empty
Tray 2	A4	Plain Paper	Ready
Tray 3	A4	Plain Paper	Empty

At the bottom of the page, there is an 'Admin Password:' field with a text input box and a 'Login' button.

The **System - Device Information - Input Tray** window provides the following information.

Item	Description
Tray	Shows the media feed units (Tray 1/2/3) installed on the machine.
Paper Size	Shows the size of paper loaded in a specific tray.
Paper Type	Shows the type of paper loaded in a specific tray.
Status	Shows the media status (“Ready” or “Empty”) for each tray.

## ROM Version

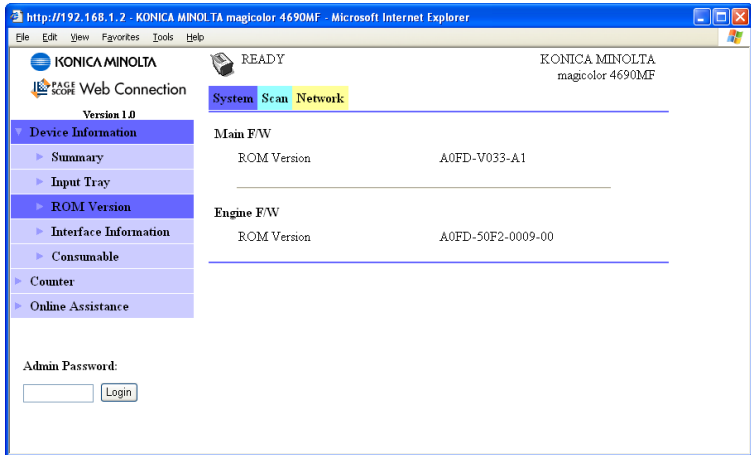

The **System - Device Information - ROM Version** window provides the following information.

Item	Description
Main F/W	Displays the ROM version of the main unit.
Engine F/W	Displays the ROM version of the printer engine.

## Interface Information

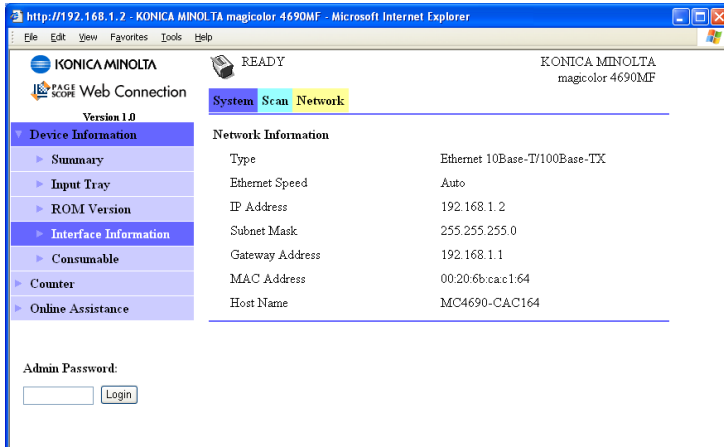

The **System - Device Information - Interface Information** window provides the following information.

Item	Description
Type	Identifies the type of network interface on the printer (Ethernet 10Base-T/100Base-TX).
Ethernet Speed	Identifies the transmission speed for the network and the transmission method for bi-directional transmission.
IP Address	Identifies the IP (Internet Protocol) address of the Ethernet interface.
Subnet Mask	Identifies the subnet mask address of the Ethernet interface.
Gateway Address	Identifies the gateway address of the Ethernet interface.
MAC Address	Identifies the Media Access Control (MAC) address of the Ethernet interface.
Host Name	Identifies the name of the printer.

## Consumable

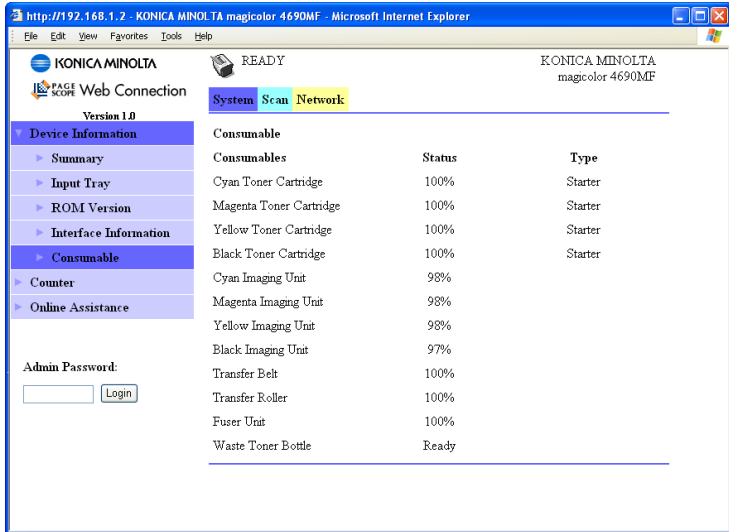

The **System - Device Information - Consumable** window provides the following information.

Item	Description
Consumables	Identifies the type of consumables that is being monitored.
Status	Identifies the remaining life of the consumables as a percentage. <ul style="list-style-type: none"> <li>■ Toner cartridge, Imaging Unit, Transfer Belt, Transfer Roller, Fuser Unit: Percentage</li> <li>■ Waste Toner Bottle: Ready, Near Full or Full</li> </ul>
Type	Identifies the maximum life expectancy of the consumables in pages. <ul style="list-style-type: none"> <li>■ Starter, Standard, High</li> </ul>

# Counter

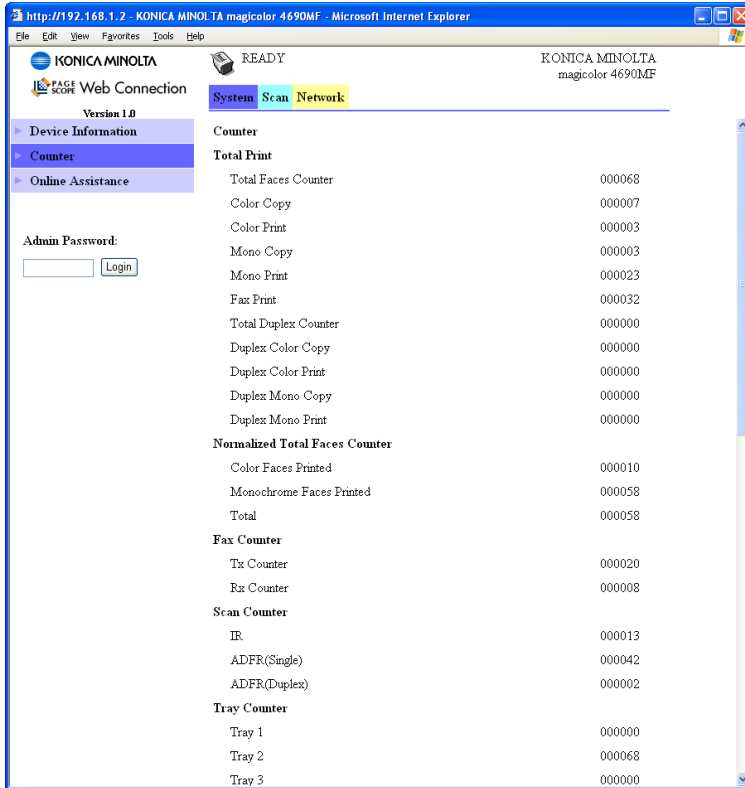

The **System - Counter** window provides the following information.

Item	Description
Total Print	Indicates the total number of all printed pages. <ul style="list-style-type: none"> <li>■ Total Faces Counter, Color Copy, Color Print, Mono Copy, Mono Print, Fax Print, Total Duplex Counter, Duplex Color Copy, Duplex Color Print, Duplex Mono Copy, Duplex Mono Print</li> </ul>
Normalized Total Faces Counter	Indicates the total number of all normalized faces printed. <ul style="list-style-type: none"> <li>■ Color Faces Printed, Monochrome Faces Printed, Total</li> </ul>
Fax Counter	Indicates the total number of fax transmission and reception pages. <ul style="list-style-type: none"> <li>■ Tx (Transmission) Counter, Rx (Reception) Counter</li> </ul>

<b>Item</b>	<b>Description</b>
Scan Counter	Indicates the total number of scanned pages. <ul style="list-style-type: none"> <li>■ IR, ADFR (Single), ADFR (Duplex)</li> </ul>
Tray Counter	Indicates the total number of pages for each tray setting. <ul style="list-style-type: none"> <li>■ Tray 1, Tray2, Tray3 (when installed)</li> </ul>
Paper Size Counter	Indicates the total number of pages for each paper size. <ul style="list-style-type: none"> <li>■ A4, B5, A5, Legal, Letter, Others</li> </ul>
Paper Type Counter	Indicates the total number of pages for each paper type. <ul style="list-style-type: none"> <li>■ Plain Paper, Recycled, Thick, Thick 2, Glossy, Glossy2, Transparency, Envelope, Letterhead, Postcard, Label</li> </ul>
Application Counter	Indicates the total number of pages for each application. <ul style="list-style-type: none"> <li>■ Copy Print, Fax Reception Print, Report Output Print, PC Print, Scan To Fax, Scan To E-mail, Scan To FTP, Scan To SMB, Scan To USB, TWAIN</li> </ul>

## Online Assistance

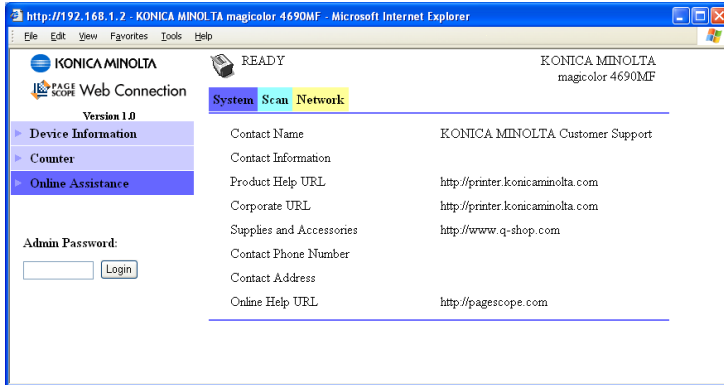

The **System - Online Assistance** window provides the following information.

Item	Description
Contact Name	Displays the name of the person or organization responsible for providing assistance with the machine.
Contact Information	Displays the web site address for assistance.
Product Help URL	Displays the help web site address for machine assistance.
Corporate URL	Displays the KONICA MINOLTA corporate web site address.
Supplies and Accessories	Displays the telephone number where you can purchase machine supplies and accessories.
Contact Phone Number	Displays the telephone number of the printer administrator.
Contact Address	Displays the e-mail address for support.
Online Help URL	Displays the web address for on-line assistance.

## Scan Page

This page allows you to view the currently specified dial settings.

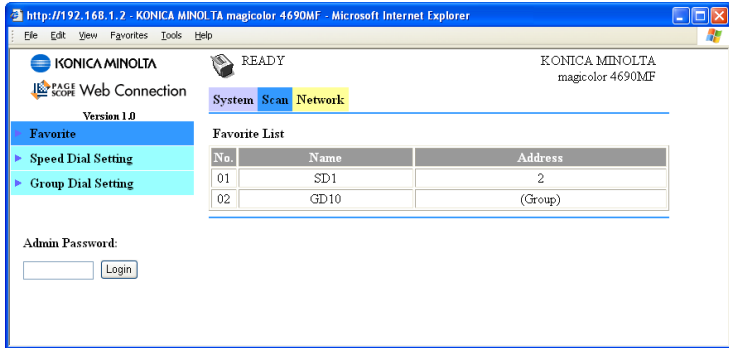

### Favorite (shown above)

The **Scan - Favorite** window provides the following information.

Item	Description
No.	Displays the number in the Favorite list.
Name	Displays the destination name of the selected speed dial number.
Address	Displays the address (phone number, fax number, e-mail address, FTP address or SMB address) of the selected speed dial number.

# Speed Dial Setting

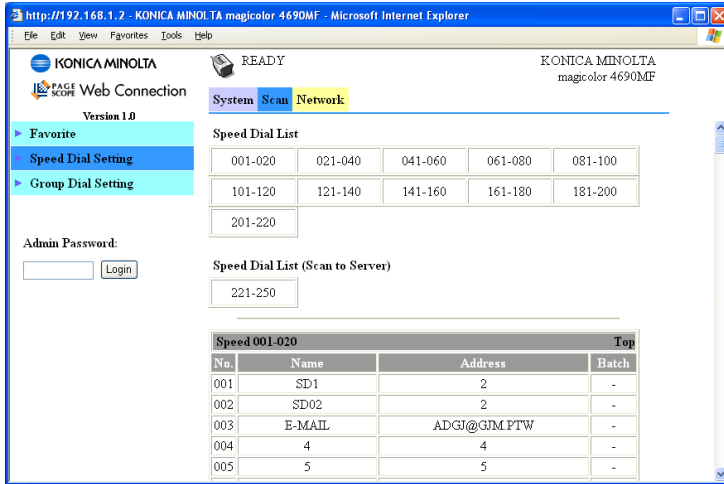

The **Scan - Speed Dial Setting** window provides the following information.

Item	Description
Speed Dial List	Click to jump to the beginning of the speed dial list within the same window.
No.	Displays the speed dial number.
Name	Displays the destination name of the speed dial number.
Address	Displays the address (fax number, e-mail address, FTP address or SMB address) of the selected speed dial number.
Batch	Displays the batch transmission time for the speed dial number.

## Group Dial Setting

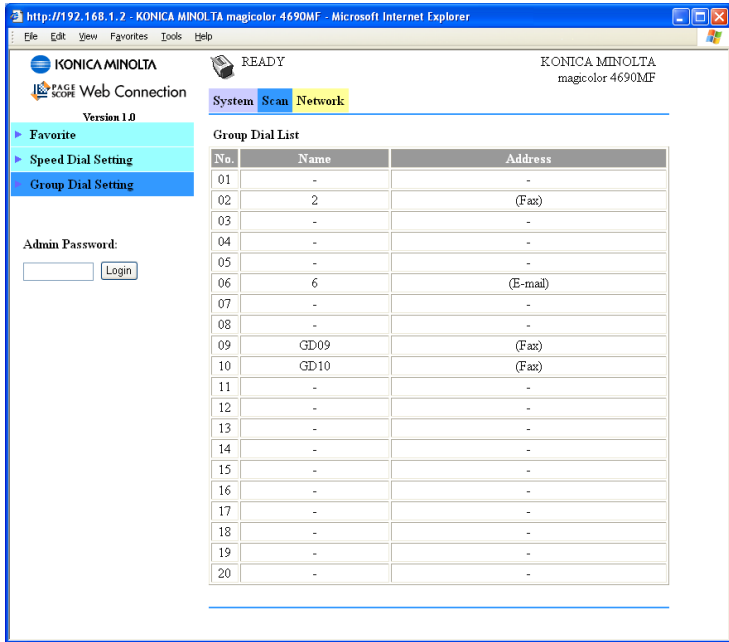

The **Scan - Group Dial Setting** window provides the following information.

Item	Description
No.	Displays the group dial number. Click the number to display the list of destinations registered with the group dial number.
Name	Displays the name of the group.
Address	Shows whether the registered group contains fax destinations or e-mail destinations.

# Network Page

This page allows you to view the current network information.

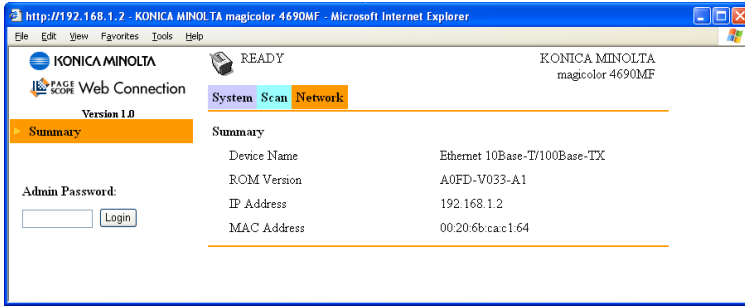

## Summary (shown above)

The **Network - Summary** window provides the following information.

Item	Description
Device Name	Displays information on the network.
ROM Version	Displays the version of the network firmware.
IP Address	Identifies the IP (Internet protocol) address of the Ethernet interface.
MAC Address	Identifies the MAC (Media Access Control) address of the Ethernet interface.

# Configuring the Printer

The Configuration page allows you to view and change the configuration settings of the printer.

## System Page

This page allows you to configure several user and specific printer items.

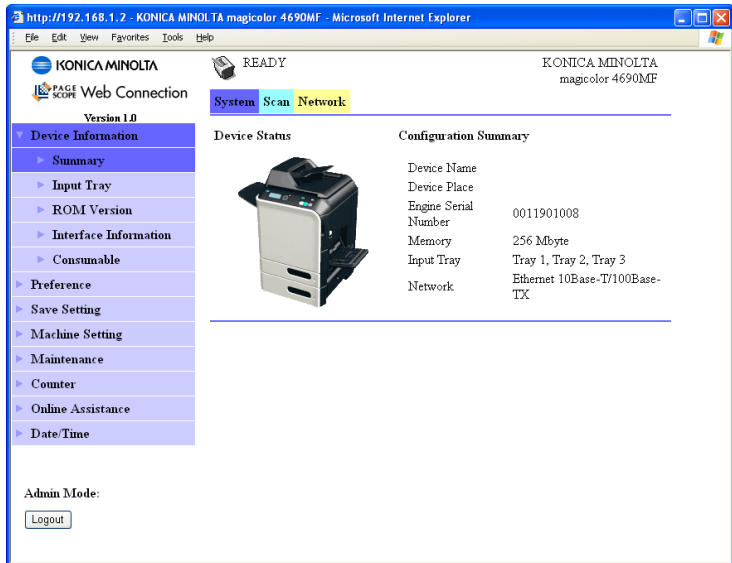

## Device Information

### Summary (shown above)

The **System - Device Information - Summary** window provides the following information.

Item	Description
Device name/status	Shows the name assigned to your machine, and displays the current status of the machine—just as it's displayed on the machine's control panel message window.  <i>The status display allows you to remotely identify possible machine problems, such as out of paper and out of toner.</i>

Item	Description
Device Status (Product image)	Identifies the type of printer that you are browsing. The printer is pictured in the illustration with all installed options.
Device Name	Displays the name of the printer.
Device Place	Displays the setup location for the printer.
Engine Serial Number	Displays the serial number of the printer engine.
Memory	Displays the amount of memory installed in the printer.
Input Tray	Identifies whether an optional lower feeder unit is "Tray1, Tray 2" or "Tray1, "Tray2, Tray3."
Network	Lists the printer interface (Ethernet 10Base-T/ 100Base-TX).
Logout button	<p>Logs out of Administrator Mode and returns to User Mode.</p> <p> <i>This button is available from all web pages.</i></p>



All of the information displayed on the **System Page - Device Information - Summary** is read-only; however, some of the items (such as the device name) are configurable on other pages.

## Input Tray

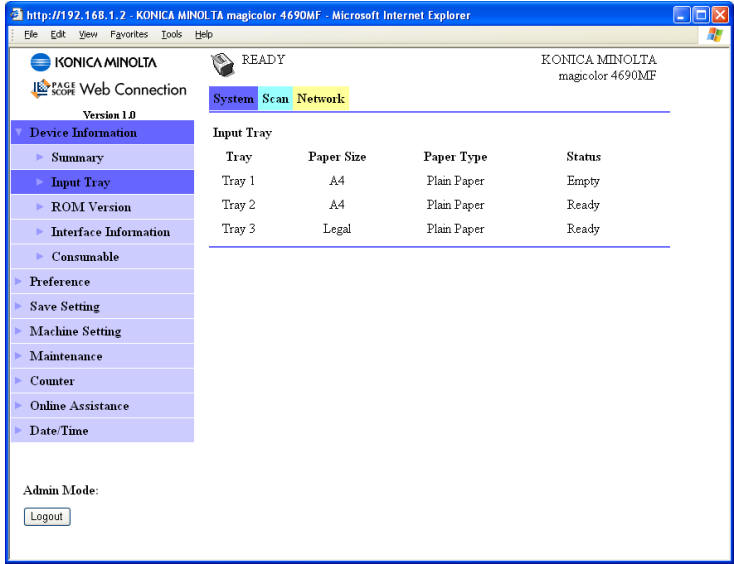

The **System - Device Information - Input Tray** window provides the following information.

Item	Description
Tray	Identifies the media feed units (Tray 1/2/3) installed on the printer. Tray 3 displays when installed.
Paper Size	Indicates the size of paper loaded in a specific tray.
Paper Type	Indicates the type of paper loaded in a specific tray.
Status	Indicates the media status ("Ready" or "Empty") for each tray.

## ROM Version

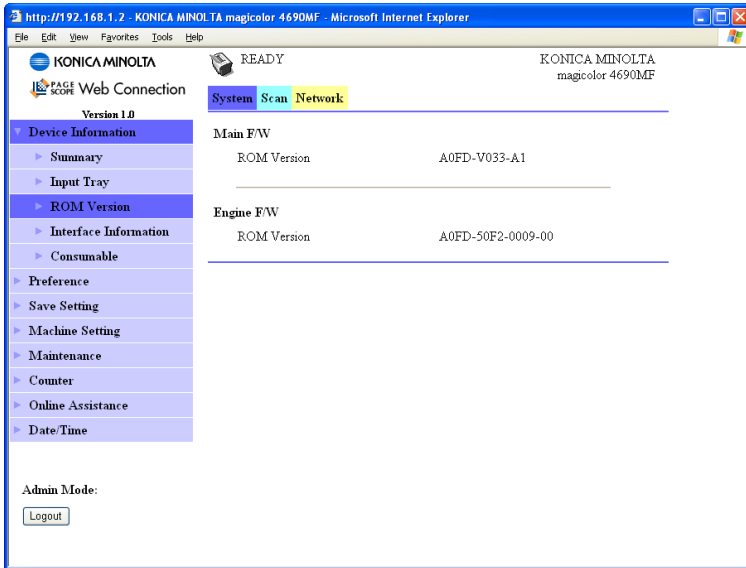

The **System - Device Information - ROM Version** window provides the following information.

Item	Description
Main F/W	Displays the ROM version of the main unit.
Engine F/W	Displays the ROM version of the printer engine.

## Interface Information

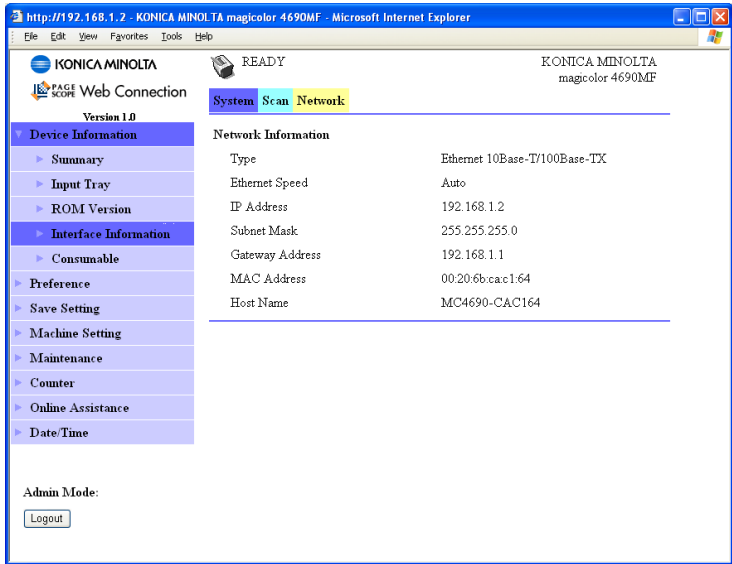

The **System - Device Information - Interface Information** window provides the following information.

Item	Description
Type	Identifies the type of network interface on the printer (Ethernet 10Base-T/100Base-TX).
Ethernet Speed	Identifies the transmission speed for the network and the transmission method for bi-directional transmission.
IP Address	Identifies the IP (Internet Protocol) address of the Ethernet interface.
Subnet Mask	Identifies the subnet mask address of the Ethernet interface.
Gateway Address	Identifies the gateway address of the Ethernet interface.
MAC Address	Identifies the Media Access Control (MAC) address of the Ethernet interface.
Host Name	Identifies the name of the printer.

## Consumable

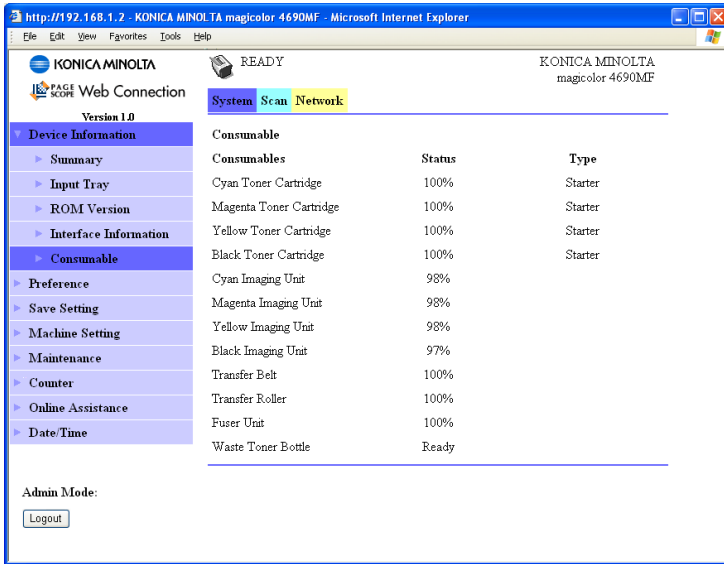



The **System - Device Information - Consumable** window provides the following information:

Item	Description
Consumables	Identifies the type of consumables that is being monitored.
Status	Indicates the remaining life of the consumables as a percentage. <ul style="list-style-type: none"> <li>■ Toner Cartridge, Imaging Unit, Transfer Belt, Transfer Roller, Fuser Unit: Percentage</li> <li>■ Waste Toner Bottle: Ready, Near Full, or Full</li> </ul>
Type	Identifies the maximum life expectancy of the consumables in pages. <ul style="list-style-type: none"> <li>■ Starter, Standard, High</li> </ul>

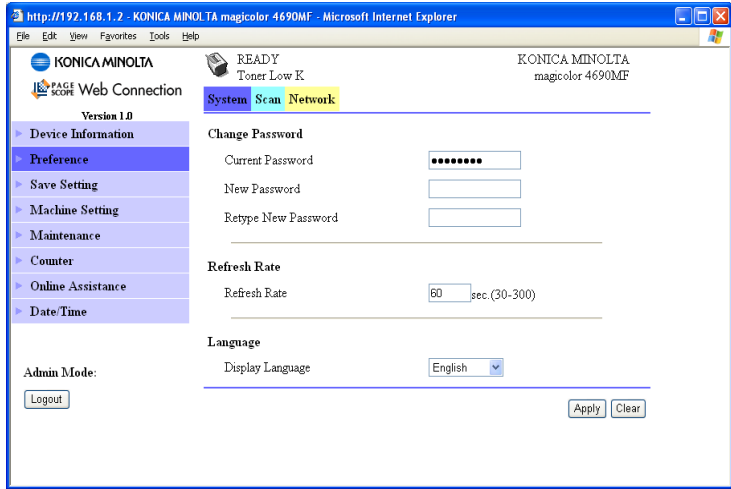
## Preference



The **System - Preference** window allows you to configure the following items:

Item	Description
Current Password	Type in the current password. Range: Up to 8 characters Default: sysadm
New Password	Sets a new password to enter Administrator Mode.  <i>Passwords can be set to any string of numbers and letters (uppercase and lowercase) between 4 and 8 characters in length.</i>
Retype New Password	Verifies the new password typed in the <b>New Password</b> text box.  <i>If the password typed in both text boxes doesn't match, the following message displays when you choose the <b>Apply</b> button: "Update Unsuccessful" Go back to the previous screen, and then retype the passwords in both text boxes.</i>

Item	Description
Refresh Rate	<p>Sets the time interval (in seconds) that passes before the screen automatically updates. During a screen refresh, the printer is polled for any new information or status, and all of the fields in the PageScope Web Connection windows are updated.</p> <p>Range: 30–300 seconds (0.5–5 minutes)            Default: 60 seconds</p> <ul style="list-style-type: none"> <li>■ If less than 30 seconds is specified, the setting changes to 30 seconds.</li> <li>■ If more than 300 seconds is specified, the setting changes to 300 seconds.</li> </ul>
Display Language	<p>Identifies the language displayed in the PageScope Web Connection windows.</p> <p>Choice: English, French, Italian, German, Spanish, Portuguese, Russian, Czech, Slovak, Hungarian, Polish, Japanese</p> <p>Default: English</p>
Apply button	Applies the configuration settings for this window.
Clear button	Resets all configuration settings for this window to their user defaults.

## Save Setting

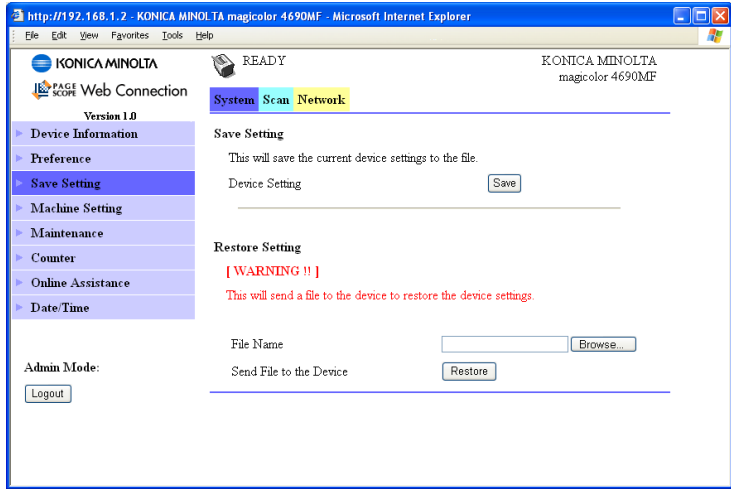

From the **System - Save Setting** window, the machine settings can be saved as a file on the computer being used. In addition, the saved settings file can be read by the machine.



*The following settings are not saved in the file:*

- IP address of the machine
- Subnet mask
- Default gateway
- Settings for DHCP, BOOTP and ARP/PING
- Phone books

Item		Description
Save Setting	Device Setting	Click <b>Save</b> button to save the machine settings as a file.
Restore Setting	File Name	Specify the name of the file where the machine settings are to be saved. Click <b>Browse</b> button to display the dialog box for browsing to the folder where the file containing the machine settings was saved.
	Send File to the Device	Click <b>Restore</b> button to send the settings file to the machine and overwrites the machine settings.

# Machine Setting

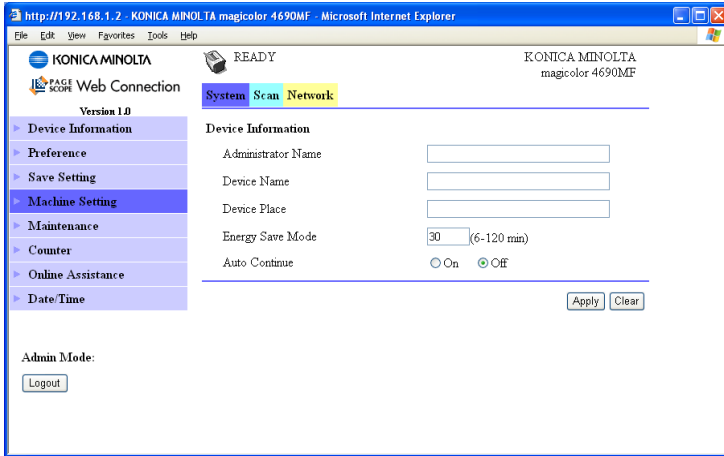

The **System - Machine Setting** window allows you to configure the following items:

Item	Description
Administrator Name	Specifies the name of the administrator for the machine. Range: Up to 127 characters Default: [Blank]
Device Name	Specifies the name of the machine. Range: Up to 127 characters Default: [Blank]
Device Place	Specifies the setup location of the machine. Range: Up to 127 characters Default: [Blank]
Energy Save Mode	Specify the length of time until the machine enters Energy Save mode. Range: 6 to 120 min. Default: 30 min. Configuration Menu Equivalent: UTILITY - MACHINE SETTING - ENERGY SAVE MODE

<b>Item</b>	<b>Description</b>
Auto Continue	Select whether Auto Continue is turned on or off. Choices: On, Off Default: Based on the machine setting Configuration Menu Equivalent: UTILITY - MACHINE SETTING - AUTO CONTINUE

# Maintenance

## Reset

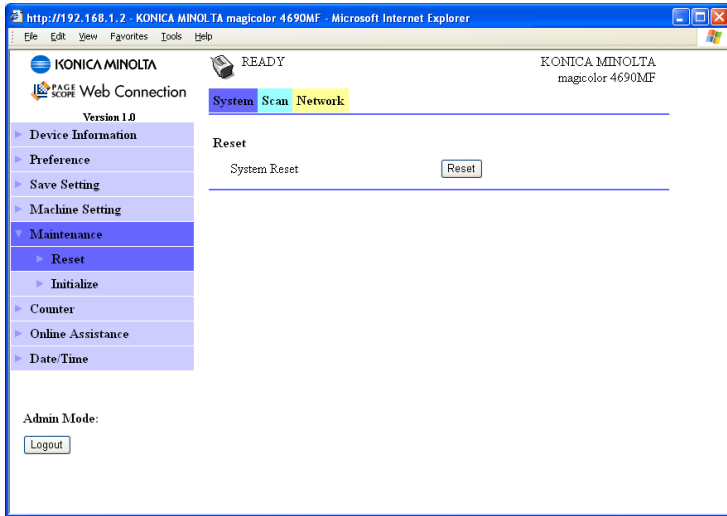

The **System - Maintenance - Reset** window allows you to reset the system.

Item	Description
Reset button	When clicked, the message “Jobs in progress will not be saved when the controller is reset. Do you want to continue?” appears. Click <b>Yes</b> to automatically restart the printer.

## Initialize

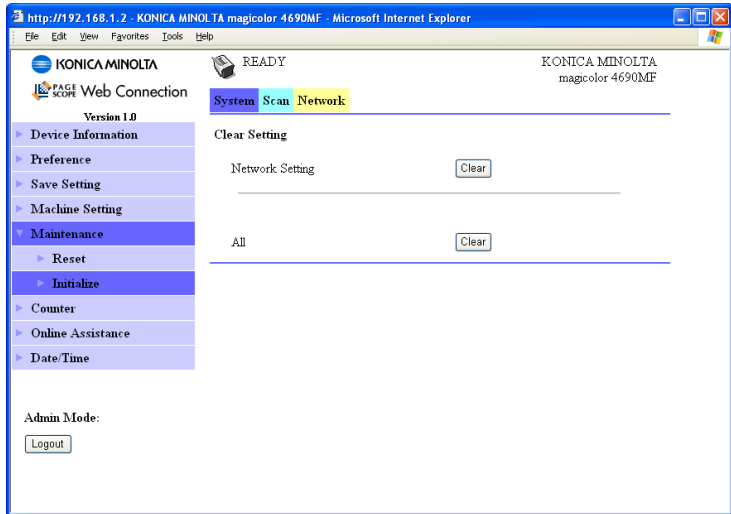

The **System - Maintenance - Initialize** window allows you to reset the machine settings to their factory defaults.

Item	Description
Network Setting	Resets the network settings to their defaults.
All	Resets all settings to their defaults.
Clear button	When clicked, the message “Do you really want to return the settings to the factory default?” appears. Click <b>Yes</b> to automatically restart the printer and return the settings to their default values.

# Counter

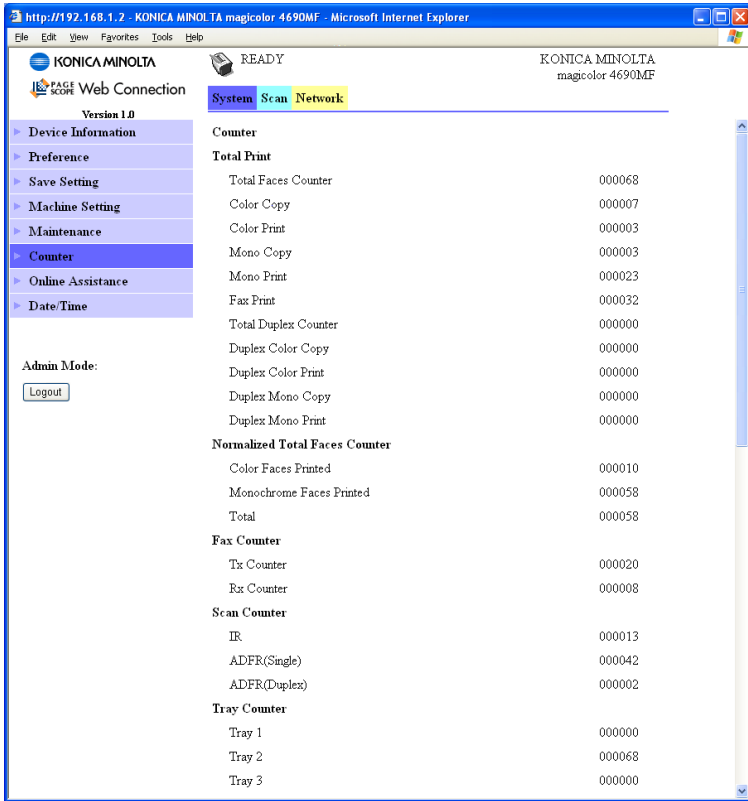

The **System - Counter** window provides the following information:

Item	Description
Total Print	Indicates the total number of all printed pages. <ul style="list-style-type: none"> <li>■ Total Faces Counter, Color Copy, Color Print, Mono Copy, Mono Print, Fax Print, Total Duplex Counter, Duplex Color Copy, Duplex Color Print, Duplex Mono Copy, Duplex Mono Print</li> </ul>
Normalized Total Faces Counter	Indicates the total number of all normalized faces printed. <ul style="list-style-type: none"> <li>■ Color Faces Printed, Monochrome Faces Printed, Total</li> </ul>

Item	Description
Fax Counter	Indicates the total number of fax transmission and reception pages. ■ Tx (Transmission) Counter, Rx (Reception) Counter
Scan Counter	Indicates the total number of scanned pages. ■ IR, ADFR (Single), ADFR (Duplex)
Tray Counter	Indicates the total number of pages for each tray setting. ■ Tray 1, Tray 2, Tray 3 (Tray 3 displays when installed)
Paper Size Counter	Indicates the total number of pages for each paper size. ■ A4, B5, A5, Legal, Letter, Others
Paper Type Counter	Indicates the total number of pages for each paper type. ■ Plain Paper, Recycled, Thick, Thick 2, Glossy, Glossy2, Transparency, Envelope, Letterhead, Postcard, Label
Application Counter	Indicates the total number of pages for each application. ■ Copy Print, Fax Reception Print, Report Output Print, PC Print, Scan To Fax, Scan To E-mail, Scan To FTP, Scan To SMB, Scan To USB, TWAIN

## Online Assistance

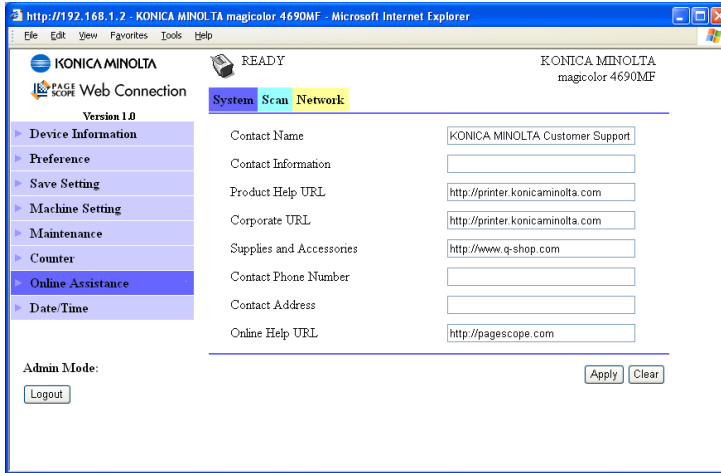

The **System - Online Assistance** window allows you to configure the following items:

Item	Description
Contact Name	Sets the name of the person or organization responsible for providing assistance with the printer. Range: Up to 63 characters Default: KONICA MINOLTA Customer Support
Contact Information	Sets the web site address for printer assistance. Range: Up to 127 characters Default: [Blank]
Product Help URL	Sets the help web site address for printer assistance. Range: Up to 127 characters Default: http://printer.konicaminolta.com
Corporate URL	Sets the KONICA MINOLTA corporate web site address. Range: Up to 127 characters Default: http://printer.konicaminolta.com
Supplies and Accessories	Sets the telephone number where you can purchase printer supplies and accessories. Range: Up to 127 characters Default: http://www.q-shop.com
Contact Phone Number	Specify the telephone number of the printer administrator. Range: Up to 31 characters Default: [Blank]

<b>Item</b>	<b>Description</b>
Contact Address	Specify the e-mail address for support. Range: Up to 320 characters Default: [Blank]
Online Help URL	Sets the web address for on-line assistance. Range: Up to 127 characters Default: <a href="http://pagescope.com">http://pagescope.com</a>
Apply button	Applies the configuration settings for this window.
Clear button	Resets all configuration settings for this window to their user defaults.

## Date/Time

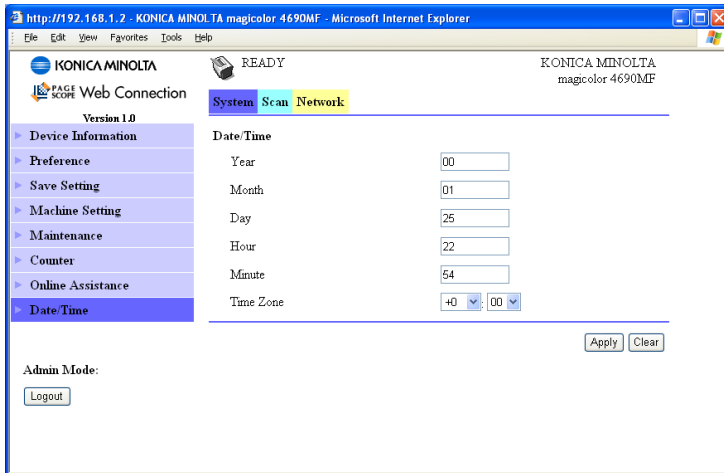

The **System - Date/Time** window provides the following information.

Item	Description
Year	Enter the year as two digits. Range: 00 to 99 Default: [Blank] Configuration Menu Equivalent: UTILITY - ADMIN. MANAGEMENT - USER SETTING - DATE&TIME
Month	Enter the month as two digits. Range: 01 to 12 Default: [Blank] Configuration Menu Equivalent: UTILITY - ADMIN. MANAGEMENT - USER SETTING - DATE&TIME
Day	Enter the day as two digits. Range: 01 to 28, 29, 30, 31 Default: [Blank] Configuration Menu Equivalent: UTILITY - ADMIN. MANAGEMENT - USER SETTING - DATE&TIME

Item	Description
Hour	Enter the hour as two digits. Range: 00 to 23 Default: [Blank] Configuration Menu Equivalent: UTILITY - ADMIN. MANAGEMENT - USER SETTING - DATE&TIME
Minute	Enter the minutes as two digits. Range: 00 to 59 Default: [Blank] Configuration Menu Equivalent: UTILITY - ADMIN. MANAGEMENT - USER SETTING - DATE&TIME
Time Zone	Specify the time zone settings (GMT and minutes). Range (Hour): GMT (-12 to 0, 0 to +12) Range (Minutes): 00, 30
Apply button	Displays the date and time as they were specified.
Clear button	Resets all configuration settings to previous values.

# Scan Page

On the **Scan** page, settings for the destination information to be registered in the machine and the fax and scan transmission/reception settings can be specified.

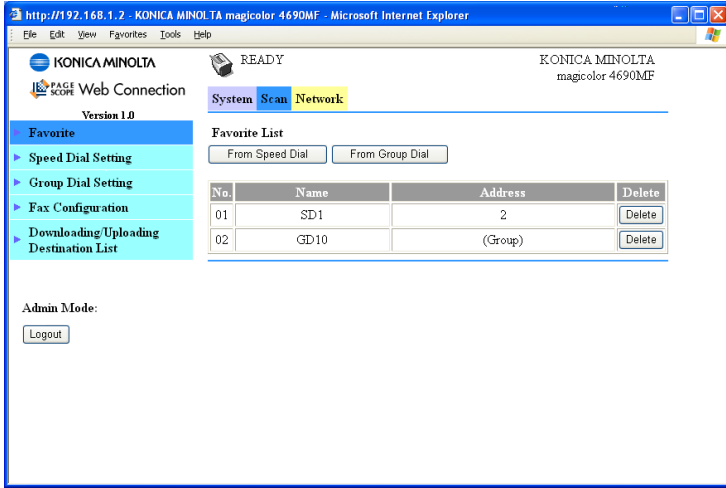

## Favorite (shown above)

The **Scan - Favorite** page, settings for speed dial and group dial can be specified.

Item	Description
No.	Displays the number in the Favorite list.
Name	Displays the destination name of the selected speed dial number.
Address	Displays the address of the selected speed dial number.
From Speed Dial button	Adds a selected speed dial list to the Favorite list. For details, refer to “From Speed Dial” on page 213.
From Group Dial button	Adds a selected group dial to the Favorite list. For details, refer to “From Group Dial” on page 215.
Delete button	Deletes the selected destination from the Favorite list.

## From Speed Dial

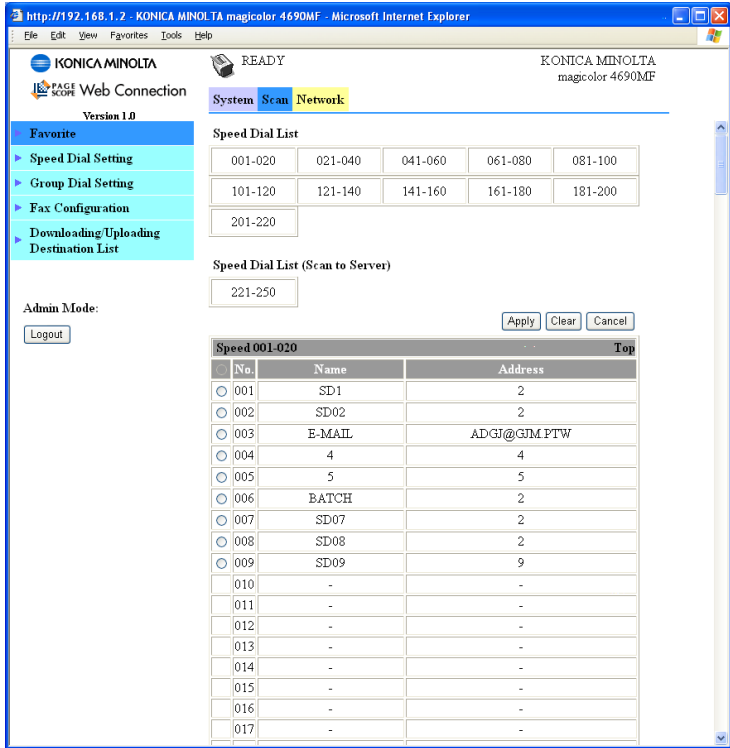

The **Scan - Favorite - Speed Dial List** window allows you to configure the following items.

Item	Description
Speed Dial List	Click to jump to the beginning of the speed dial list within the same page.
Radio button	Select a radio button to select a destination registered in the list. Default: Cleared.
No.	Displays the speed dial number.
Name	Displays the destination of the speed dial number.
Address	Displays the destination information (fax number, e-mail address, FTP address or SMB address) registered with the speed dial number.
Apply button	Applies configuration settings for this window.

<b>Item</b>	<b>Description</b>
Clear button	Resets all configuration settings for this window to their user defaults.
Cancel button	Cancels the operation and returns to the Favorite List page.

## From Group Dial

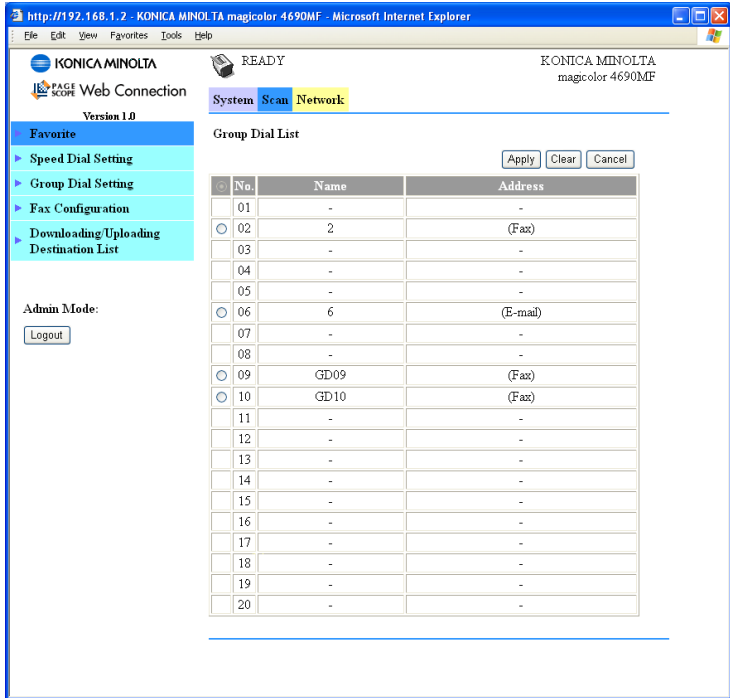

The **Scan - Favorite - Group Dial List** window allows you to configure the following items:

Item	Description
Radio button	Select a radio button to select a destination registered in the list. Default: Cleared
No.	Displays the group dial number.
Name	Displays the name of the group.
Address	Shows whether the registered group contains fax destinations or e-mail destinations.
Apply button	Applies the configuration settings for this window.
Clear button	Resets all configuration settings for this window to their user defaults.
Cancel button	Cancels the operation and returns to the Favorite List page.

# Speed Dial Setting

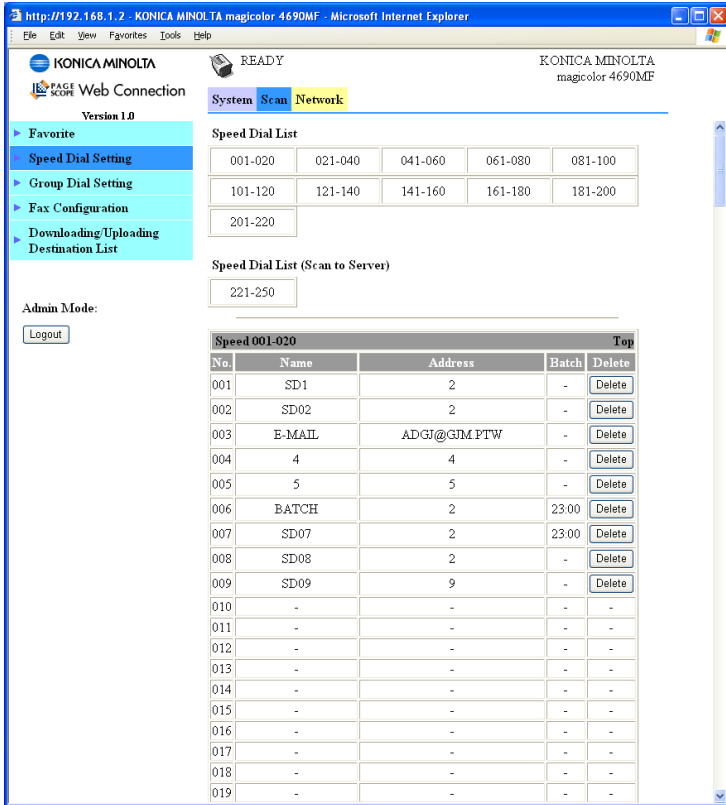

The **Scan - Speed Dial Setting** window, settings for speed dialing can be specified.

Item	Description
Speed Dial List	Click to jump to the beginning of the speed dial list within the same page. Speed Dial number of 001 - 220 are Fax and E-mail destinations. Speed Dial number of 221 - 250 are FTP and SMB destinations.

Item	Description
No.	<p>Displays the number in the speed dial list. Click a speed dial number where no destination is registered to add a destination from the <b>Speed Dial Registration</b> page. If a destination is already registered with the speed dial number that is clicked, the registered information can be edited.</p> <p>When registering a fax, e-mail and LDAP Search, refer to “Speed Dial Registration” on page 218.</p> <p>When registering an FTP or SMB destination, refer to “Speed Dial Registration (Scan to Server)” on page 222.</p>
Name	Displays the destination name of the speed dial number.
Address	Displays the destination information (fax number, e-mail address, FTP address or SMB address) registered with the speed dial number.
Batch	Displays the batch transmission time for speed dial number.
Delete button	Deletes the selected destination from the speed dial.

## Speed Dial Registration

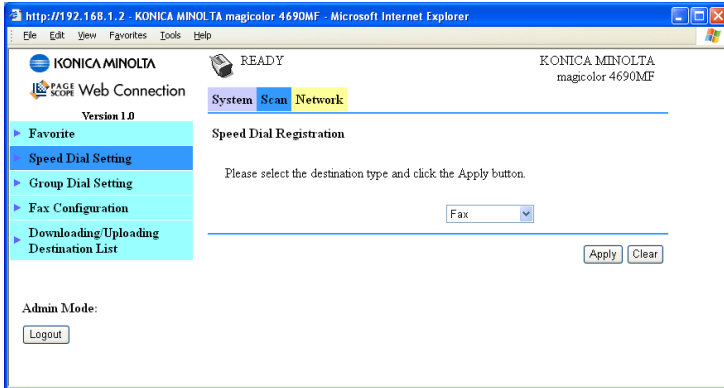

The **Scan - Speed Dial Setting - Speed Dial Registration** window, select the type of Speed dial destination to be added.

Item	Description
Speed Registration	<p>From the drop-down list, select the type of speed dial destination to be added.</p> <p>If “Fax” is selected, the <b>Fax Destination</b> page will be displayed. For details, refer to “Fax Destination” on page 219.</p> <p>If “E-mail” is selected, the <b>E-mail Destination</b> page will be displayed. For details, refer to “E-mail Destination” on page 220.</p> <p>If “LDAP Search” is selected, the <b>LDAP Search</b> page will be displayed. For details, refer to “LDAP Search” on page 221.</p> <p>Choices: Fax, E-mail, LDAP Search Default: Fax</p>
Apply button	Displays the page for the type of speed dial destination selected from the list.
Clear button	Resets all configuration settings for this window to their user defaults.

## Fax Destination

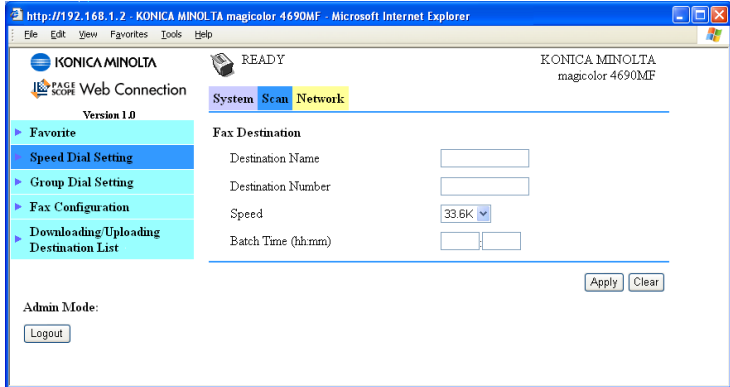

The **Scan - Speed Dial Setting - Fax Destination** window allows you to configure the following items:

Item	Description
Destination Name	Specify the name of the destination. Range: Up to 20 characters. Default: [Blank]
Destination Number	Specify the fax number for the destination. Range: Up to 50 characters Default: [Blank]
Speed	Select the speed of the fax modem. Choices: 9.6K, 14.4K, 33.6K Default: 33.6K
Batch Time (hh: mm)	Specify the batch transmission time of speed dial. Range: 00:00 to 23:59 Default: [Blank]
Apply button	Applies the configuration settings for this window.
Clear button	Resets all configuration settings for this window to their user defaults.

## E-mail Destination

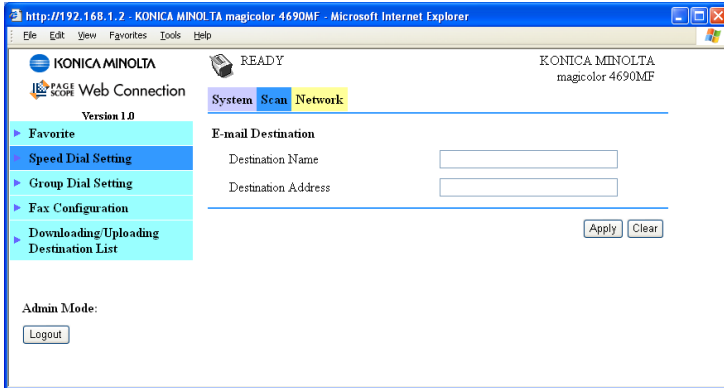

The **Scan - Speed Dial Setting - E-mail Destination** window allows you to configure the following items:

Item	Description
Destination Name	Specify the name of the destination. Range: Up to 20 characters. Default: [Blank]
Destination Address	Specify the E-mail address of the destination. Range: Up to 64 characters Default: [Blank]
Apply button	Applies the configuration settings for this window.
Clear button	Resets all configuration settings for this window to their user defaults.

## LDAP Search

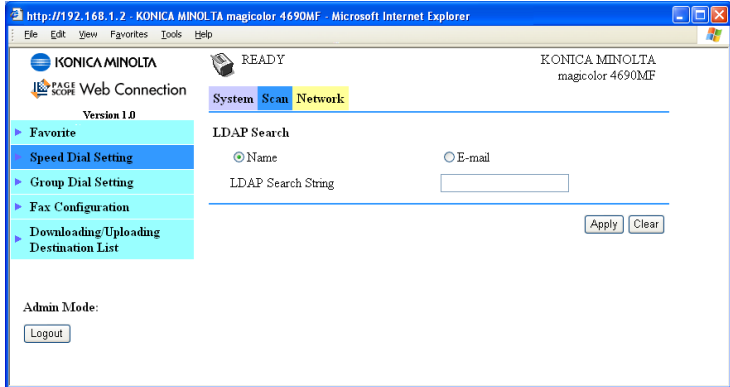

The **Scan - Speed Dial Setting - LDAP Search** window allows you to configure the following items:

Item	Description
LDAP Search	Specify the method for searching for the destination. Choices: Name, E-mail Default: Name
LDAP Search String	Specify the LDAP search string. Range: Up to 20 characters Default: [Blank]
Apply button	Starts the LDAP searching.
Clear button	Resets all configuration settings for this window to their user defaults.

## Speed Dial Registration (Scan to Server)

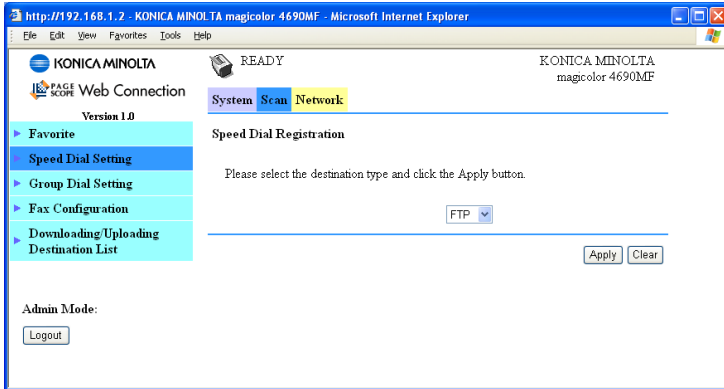

On the **Scan - Speed Dial Setting - Speed Dial Registration** page, select the server type of speed dial destination to be added.

Item	Description
Speed Dial Registration	From the drop-down list, select the type of speed dial destination to be added. If "FTP" is selected, refer to "For FTP Server" on page 223. If "SMB" is selected, refer to "For SMB server" on page 227. Choices: FTP, SMB Default: FTP
Apply button	Displays the page for the type of speed dial destination selected from the list.
Clear button	Resets all configuration settings for this window to their user defaults.

## For FTP Server

http://192.168.1.2 - KONICA MINOLTA magicolor 4690MF - Microsoft Internet Explorer

File Edit View Favorites Tools Help

KONICA MINOLTA READY KONICA MINOLTA magicolor 4690MF

Web Connection System Scan Network

Version 1.0

**Favorite**

- Speed Dial Setting
- Group Dial Setting
- Fax Configuration
- Downloading/Uploading Destination List

Admin Mode:

**File Destination**

Destination Name: TEST\_FTP

FTP Server Address: 192.168.1.100

Directory: /public

Use Proxy:

Remote Port Number: 21 (1-65535)

**Basic Setting**

Color Setting: BW Only

Resolution: 300x300

Mode: MX

Attachment file format: PDF

Coding method: MH

Scan area: A4

**E-mail Notification**

Enable Notification:

Notification Address:

No.1: user1@test.local

No.2:

No.3:

No.4:

No.5:

No.6:

No.7:

No.8:

No.9:

No.10:

**Account Information**

Anonymous

Private Site





User Name	user1
Password	****
Confirm	****

The **Scan - Speed Dial Setting** of speed dial registration (for FTP server) window allows you to configure the following items:



*The **Network - FTP** screen, set to “Enable” from **Send** when sending to FTP server. Also, when sending via proxy server, specify the proxy server setting. For details, refer to “FTP” on page 269.*

Item		Description
File Destination	Destination Name	Specify the name of the destination. Range: Up to 20 characters Default: [Blank]
	FTP Server Address	Specify the destination of IP address for FTP server. When using DNS server, host name can be specified instead of IP address. Range: Up to 64 characters Default: [Blank]
	Directory	Specify the destination directory on the FTP server. Range: Up to 128 characters Default: [Blank]
	Use Proxy	Select whether or not to use a proxy server to access the FTP server. Choices: On, Off Default: Off
	Remote Port Number	Specify the number of the port for the FTP server when a proxy server is not specified. Range: 1 to 65535 Default: 21

Item		Description
Basic Setting	Color Setting	Select the color tone to be used. Choices: BW Only, Color or Gray Default: BW Only
	Resolution	Select the resolution of the scanner. Choices: 150 x 150, 300 x 300, 600 x 600 Default: 300 x 300  <i>If “Color Setting” is set to “Color or Gray”, “600 x 600” cannot be selected.</i>
	Mode	Select the mode type for the scanner. Choices: Text, Photo, MIX Default: MIX  <i>If “Color Setting” is set to “BW Only”, select a setting.</i>
	Attachment File Format	Select the desired file format. Choices: TIFF, PDF, JPEG Default: PDF  <i>If “Color Setting” is set to “BW Only”, “JPEG” cannot be selected.</i>
	Coding Method	Select the coding method. Choices: MH, MR, MMR Default: MH  <i>If “Color Setting” is set to “Color or Gray”, no setting can be selected.</i>
	Scan Area	Select the scanning area. Choices: A5, B5, A4, ST, LT, LG Default: A4 (metric), LT (inch)

Item		Description
E-Mail Notification	Enable Notification	Select whether or not e-mail notifications are to be sent after a transmission to an FTP server is completed. Choices: On, Off Default: Off   <i>E-mail notification is not available when <b>Disable</b> is selected of <b>SMTP</b> in <b>Network - E-mail</b> screen.</i>
	Notification Address	Register the destination e-mail address of notification. Up to 10 addresses can be registered. Range: Up to 64 characters Default: [Blank]
Account Information	Anonymous/Private Site	Select the type of account used for logging into the FTP server. If "Anonymous" is selected, log in with "Anonymous" as the account name and "guest" as the password. If "Private Site" is selected, be sure to specify settings for <b>User Name</b> , <b>Password</b> and <b>Confirm</b> . Choices: Anonymous, Private Site Default: Anonymous
	User Name	Specify the user name to log in to FTP server when Private Site is selected. Range: Up to 20 characters
	Password	Specify the password to log in to FTP server when Private Site is selected. Range: Up to 20 characters
	Confirm	Type in the password again for confirmation. Range: Up to 20 characters
Apply button		Applies the configuration settings for this window.
Clear button		Resets all configuration settings to previous values.



## For SMB server



The screenshot shows the Konica Minolta Web Connection interface in Microsoft Internet Explorer. The browser address bar shows `http://192.168.1.2 - KONICA MINOLTA magicolor 4690MF - Microsoft Internet Explorer`. The page title is "READY" and the status is "KONICA MINOLTA magicolor 4690MF". The navigation menu includes "System", "Scan", and "Network", with "Network" selected. The left sidebar shows "Favorite" with sub-items: "Speed Dial Setting", "Group Dial Setting", "Fax Configuration", and "Downloading/Uploading Destination List". Below the sidebar is an "Admin Mode" section with a "Logout" button. The main content area is titled "Version 1.0" and contains several sections: "File Destination" with fields for "Destination Name" (TEST\_SMB), "Destination Address" (192.168.1.4), and "Directory" (/file); "Basic Setting" with dropdown menus for "Color Setting" (BW Only), "Resolution" (300x300), "Mode" (MX), "Attachment file format" (PDF), "Coding method" (MH), and "Scan area" (A4); "E-mail Notification" with a checked "Enable Notification" checkbox and ten "Notification Address" fields (No. 1 to No. 10), where No. 1 contains "user1@test.local"; and "Account Information" with radio buttons for "Anonymous" and "Private Site", and input fields for "User Name" (user1), "Password" (masked with dots), and "Confirm" (masked with dots). At the bottom right are "Apply" and "Clear" buttons.

The **Scan - Speed Dial Setting** of speed dial registration (for SMB server) window allows you to configure the following items:



The **Network - SMB** screen, set to "Enable" from **Send** when sending to SMB server. For details, refer to "SMB" on page 270.

Item		Description
File Destination	Destination Name	Specify the name of the destination. Range: Up to 20 characters Default: [Blank]
	Destination Address	Specify the destination IP address of SMB server or NetBIOS. Range: Up to 64 characters Default: [Blank]
	Directory	Specify the destination directory on the SMB server. Range: Up to 128 characters Default: [Blank]
Basic Setting	Color Setting	Select the color tone to be used. Choices: BW Only, Color or Gray Default: BW Only
	Resolution	Select the resolution of the scanner. Choices: 150 x 150, 300 x 300, 600 x 600 Default: 300 x 300   <i>If "Color Setting" is set to "Color or Gray", "600 x 600" cannot be selected.</i>
	Mode	Select the mode type for the scanner. Choices: Text, Photo, MIX Default: MIX   <i>If "Color Setting" is set to "BW Only", select a setting.</i>

Item	Description	
	Attachment File Format	Select the desired file format. Choices: TIFF, PDF, JPEG Default: PDF   <i>If “Color Setting” is set to “BW Only”, “JPEG” cannot be selected.</i>
	Coding Method	Select the coding method. Choices: MH, MR, MMR Default: MH If “Color Setting” is set to “Color or Gray”, no setting can be selected.
	Scan Area	Select the scanning area. Choices: A5, B5, A4, ST, LT, LG Default: A4 (metric), LT (inch)
E-mail Notification	Enable Notification	Select whether or not e-mail notifications are to be sent after a transmission to an SMB server is completed. Choices: On, Off Default: Off   <i>E-mail notification is not available when <b>Disable</b> is selected of <b>SMTTP</b> in <b>Network - E-mail</b> screen.</i>
	Notification Address	Register the destination e-mail address of notification. Up to 10 addresses can be registered. Range: Up to 64 characters Default: [Blank]

Item		Description
Account Information	Anonymous/Private Site	Select the type of account used for logging into the FTP server. If "Anonymous" is selected, log in with "Anonymous" as the account name and "guest" as the password. If "Private Site" is selected, be sure to specify settings for <b>User Name, Password and Confirm</b> . Choices:    Anonymous, Private Site Default:    Anonymous
	User Name	Specify the user name to log in to SMB server when Private Site is selected. Range:    Up to 20 characters
	Password	Specify the password to log in to SMB server when Private Site is selected. Range:    Up to 20 characters
	Confirm	Type in the password again for confirmation. Range:    Up to 20 characters
Apply button		Applies the configuration settings for this window.
Clear button		Resets all configuration settings to previous values.

## Group Dial Setting

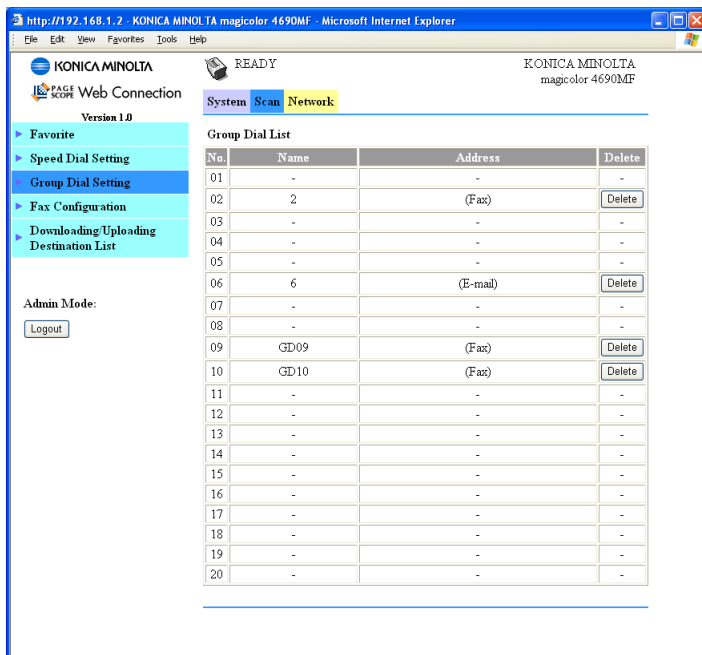

On the **Scan - Group Dial Setting** page, settings for group dialing can be specified.

Item	Description
No.	Displays the number in the group dial list. Click a group dial number where no destinations is registered to add in the <b>Group Dial Registration</b> page. For details, refer to “Group Dial Registration (Destination type)” on page 232. If a group is already registered with the number that is clicked, the registered information can be edited.
Name	Displays the name of the group dial.
Address	Shows whether the registered group contains fax destinations or e-mail destinations.
Delete button	Deletes the corresponding group dial.

## Group Dial Registration (Destination type)

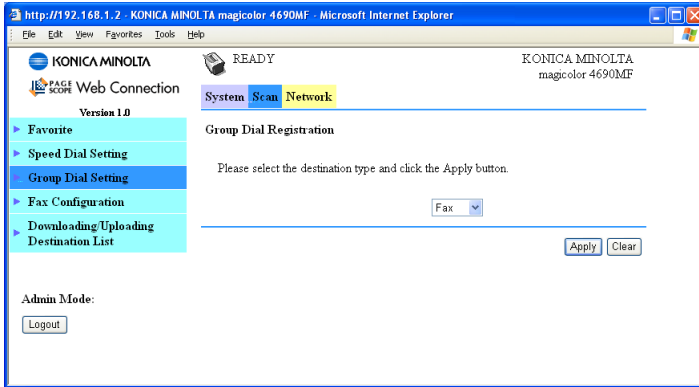

In the **Scan - Group Dial Setting - Group Dial Registration** window, select the type of group dial destination to be added.

Item	Description
Group Registration	<p>From the drop-down list, select the type of group dial destination to be added.</p> <p>If “Fax” is selected, a group of <b>Fax destinations</b> will be displayed.</p> <p>If “E-mail” is selected, a group of <b>E-mail destinations</b> will be displayed.</p> <p>For details, refer to “Group Dial Registration (Add Destinations)” on page 233.</p> <p>Choices: Fax, E-mail</p> <p>Default: Fax</p>
Apply button	Displays the page for the type of speed dial destination selected from the list.
Clear button	Resets all configuration settings in this page to their user defaults.

## Group Dial Registration (Add Destinations)

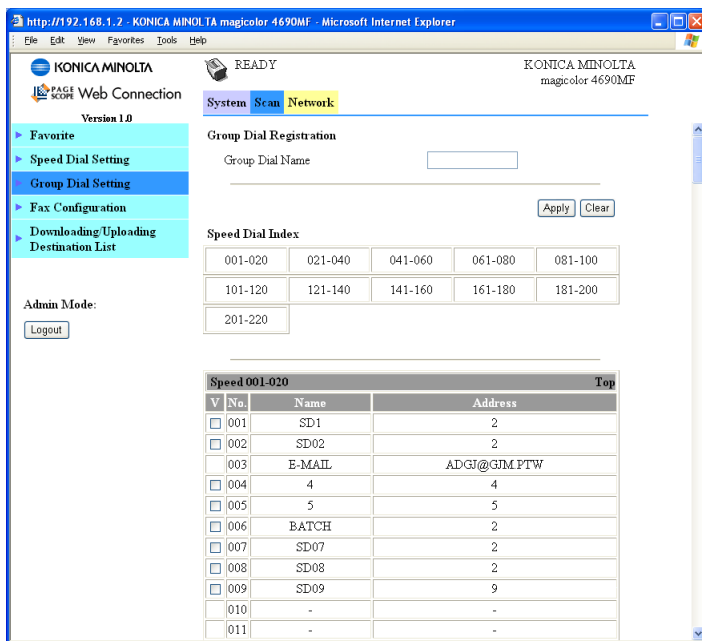

The **Scan - Group Dial Setting - Group Dial Registration** window allows you to configure the following items:

Item	Description
Group Dial Name	Specify the name of the group dial. Range: Up to 20 characters. Default: [Blank]
Speed Dial Index	Click to jump to the beginning of the speed dial list within the same page.
Speed 001-020 Speed 021-040 Speed 041-060 Speed 061-080 Speed 081-100 Speed 101-120 Speed 121-140 Speed 141-160 Speed 161-180 Speed 181-200 Speed 201-220	Displays the list of registered speed dial numbers, 20 at a time. Select the check box on the left side of the list to add the corresponding speed dial destination to a group dial.  <i>SMB and FTP destination type cannot be registered in the group dial. The registered speed dial that contains fax destination and e-mail address cannot be registered in a same group.</i>
Apply button	Applies the configuration settings for this window.

<b>Item</b>	<b>Description</b>
Clear button	Resets all configuration settings for this window to their user defaults.

# Fax Configuration

http://192.168.1.2 - KONICA MINOLTA magicolor 4690MF - Microsoft Internet Explorer

KONICA MINOLTA READY KONICA MINOLTA magicolor 4690MF

System Scan Network

Version 1.0

Admin Mode:

**Favorite**  
Speed Dial Setting  
Group Dial Setting  
**Fax Configuration**  
Downloading/Uploading  
Destination List

**User Data Registration**  
User Name (32 char.)   
Fax Number (20 char.)

**Transmission Operation**  
Density Level   
Quality Priority   
Default TX  Memory TX  Direct TX  
Header

**Reception Operation**  
Memory RX Mode   
On Time  :   
Off Time  :   
Password (XXXXX)   
Number of Rings  times (1-16)  
Reduction RX   
RX Print  Memory RX  Print RX  
RX Mode  Auto RX  Manual RX  
Forward Mode   
Forward Address   
Footer Enable   
Select Tray  
Tray 1  Enable  Disable  
Tray 2  Enable  Disable  
Tray 3  Enable  Disable

**Communication Setting**  
Tone/Pulse   
Line Monitor Volume   
PSTN/PBX  PSTN  PBX (  )

**Reporting**  
Activity Report   
TX Result Report   
RX Result Report

**User Settings**  
Fax PTT Setting UK.  
Date Format   
Preset Zoom  Inch  Metric

**Auto Redial Setting**  
Number of Redials  times (1-10)  
Redial Interval  minutes (2-99)



In the **Scan - Fax Configuration** page, user information can be registered.



Item	Description	
User Data Registration	User Name	Specify the user name. Range: Up to 32 characters Default: [Blank] Configuration Menu Equivalent: UTILITY - ADMIN. MANAGEMENT - USER SETTING - USER NAME
	Fax Number	Specify the fax number. Range: Up to 20 characters Default: [Blank] Configuration Menu Equivalent: UTILITY - ADMIN. MANAGEMENT - USER SETTING - USER FAX NUMBER
Transmission Operation	Density Level	Specify the density level for fax scanning. Choices: -1, 0, +1 Default: 0 Configuration Menu Equivalent: UTILITY - FAX TX OPERATION - DENSITY LEVEL
	Quality Priority	Select the quality setting given priority with fax scanning. Choices: Standard/Text, Fine/Text, Super Fine/Text, Standard/Photo, Fine/Photo, Super Fine/Photo Default: Standard/Text Configuration Menu Equivalent: UTILITY - FAX TX OPERATION - QUALITY PRIORITY
	Default TX	Select the default transmission mode. Choices: Memory TX, Direct TX Default: Memory TX Configuration Menu Equivalent: UTILITY - FAX TX OPERATION - DEFAULT TX

Item	Description	
	Header	<p>Select whether or not the transmission information (date sent, sender's name, fax number, etc.) is printed on sent faxes.</p> <p>Choices: On, Off</p> <p>Default: On</p> <p>Configuration Menu Equivalent:</p> <p style="text-align: center;">UTILITY - FAX TX OPERATION - HEADER</p> <p> If "Fax PTT Setting" is set to "U.S.A", "Canada" or "Korea", no setting other than "On" can be selected; therefore, this parameter does not appear.</p>
Reception Operation	Memory RX Mode	<p>Select whether to allow ("On") memory reception or not ("Off"). In cases when confidential faxes are being received, the received document can be stored in the memory and printed at a specified time or when memory reception is set to "Off". A password can be set to specify the starting time or ending time of memory reception, or to cancel the function. The set of starting time and ending time are valid every day until memory reception is turned off.</p> <p>Choices: Off, On</p> <p>Default: Off</p> <ul style="list-style-type: none"> <li>■ On Time           <ul style="list-style-type: none"> <li>Range: 00:00 to 23:59</li> <li>Default: [Blank]</li> </ul> </li> <li>■ Off Time           <ul style="list-style-type: none"> <li>Range: 00:00 to 23:59</li> <li>Default: [Blank]</li> </ul> </li> <li>■ Password           <ul style="list-style-type: none"> <li>Range: 0000 to 9999</li> <li>Default: [Blank]</li> </ul> </li> </ul> <p>Configuration Menu Equivalent:</p> <p style="text-align: center;">UTILITY - FAX RX OPERA- TION - MEMORY RX MODE</p>

Item		Description
	Number of Rings	Specify the number of rings that are sounded. Range: 1 to 16 Configuration Menu Equivalent: UTILITY - FAX RX OPERA- TION - NUMBER OF RINGS
	Reduction RX	Select whether documents longer than the paper are printed reduced, split, or discarded. If "On" is selected, received faxes are printed reduced. If "Off" is selected, received faxes are printed at full size and split onto multiple pages. If "Cut" is selected, received faxes are printed while erasing any part that does not fit within the page. However, when sending a document more than 24 mm (1 inch) longer than the paper, "Cut" is not available. (In this case, the document is split.) Choices: On, Off, Cut Default: On Configuration Menu Equivalent: UTILITY - FAX RX OPERA- TION - REDUCTION RX

Item		Description
	RX Print	<p>Select whether the fax is printed only after all document pages have been received or printing begins as soon as the first page of the document is received.</p> <p>If "Memory RX" is selected, printing begins after all pages have been received.</p> <p>If "Print RX" is selected, printing begins after the first page has been received.</p> <p>Choices: Memory RX, Print RX</p> <p>Default: Memory RX</p> <p>Configuration Menu Equivalent:  UTILITY - FAX RX OPERA-  TION - RX PRINT</p>
	RX Mode	<p>Select the reception mode.</p> <p>Choices: Auto RX, Manual RX</p> <p>Default: Auto RX</p> <p>Configuration Menu Equivalent:  UTILITY - FAX RX OPERA-  TION - RX MODE</p>
	Forward Mode	<p>Select the forwarding mode.</p> <p>Choices: Off, On, On (Print)</p> <p>Default: Off</p> <p>Configuration Menu Equivalent:  UTILITY - FAX RX OPERA-  TION - FORWARD</p>
	Forward Address	<p>Specify the forwarding address for faxes or e-mail.</p> <p>Range: Up to 30 characters (Fax), 64 character (E-mail)</p> <p>Default: [Blank]</p> <p>Configuration Menu Equivalent:  UTILITY - FAX RX OPERA-  TION - FORWARD</p>
	Footer Enable	<p>Select whether or not the footer is printed.</p> <p>Choices: On, Off</p> <p>Default: Off</p> <p>Configuration Menu Equivalent:  UTILITY - FAX RX OPERA-  TION - FOOTER</p>

Item		Description
	Select Tray	<p>This parameter can be used to select which paper trays can be used to supply paper when printing received documents or transmission reports. The paper trays can also be set so that they cannot be used for supplying paper.</p> <p>Choices: Enable or Disable (Tray 1, Tray 2, Tray 3)</p> <p>Default: Enable (Tray 1, Tray 2, Tray 3)</p> <p>Configuration Menu Equivalent: UTILITY - FAX RX OPERA- TION - SELECT TRAY</p> <p> <i>“Tray 3” appears only if an optional lower feeder unit is installed.</i></p>
Communi- cation Set- ting	Tone/Pulse	<p>Select a tone or pulse dialing mode. If this parameter is not specified correctly, faxes cannot be sent.</p> <p>Choices: Tone, Pulse 10PPS, Pulse 20PPS</p> <p>Default: Tone</p> <p>Configuration Menu Equivalent: UTILITY - ADMIN. MANAGE- MENT - COMM. SETTING - TONE/PULSE</p> <p> <i>If “Fax PTT Setting” is set to “U.S.A”, “Canada” or “New Zealand”, no setting other than “Pulse” can be selected.</i></p>

Item		Description
	Line Monitor Volume	<p>Select the volume of the monitoring sound of the transmission signal.            Choices: High, Low, Off            Default: Low            Configuration Menu Equivalent:            UTILITY - ADMIN. MANAGE-            MENT - COMM. SETTING -            LINE MONITOR</p> <p> <i>Even when "Off" is selected, the monitoring sound can be heard when the "On hook" key in the control panel is pressed.</i></p>
	PSTN/PBX	<p>Select whether the connected telephone wiring is a public switched telephone network (PSTN) or a private branch exchange (PBX).            Choices: PSTN, PBX            Default: PSTN            Configuration Menu Equivalent:            UTILITY - ADMIN. MANAGE-            MENT - COMM. SETTING -            PSTN/PBX</p> <p> <i>When "PBX" is selected, the PBX number can be set between 0 and 9999.</i></p>

Item	Description	
Reporting	Activity Report	<p>A report can be printed to show the results of transmissions/receptions.</p> <p>Choices: On, Off</p> <p>Default: On</p> <p>Configuration Menu Equivalent:</p> <p style="text-align: center;">UTILITY - REPORTING - ACTIVITY REPORT</p>
	TX Result Report	<p>Select whether or not a report showing the results of a transmission is printed automatically after the transmission is finished.</p> <p>If "ON" is selected, a report is printed after each transmission is finished.</p> <p>If "ON (ERROR)" is selected, a report is printed after the transmission only if an error occurred.</p> <p>If "OFF" is selected, a report is not printed after each transmission is finished. The report is not printed even if an error occurred.</p> <p>Choices: On, On (Error), Off</p> <p>Default: On (Error)</p> <p>Configuration Menu Equivalent:</p> <p style="text-align: center;">UTILITY - REPORTING - TX RESULT REPORT</p>
	RX Result Report	<p>Select whether or not a report showing the results of a reception is printed automatically after the reception is finished.</p> <p>If "ON" is selected, a report is printed after each reception is finished.</p> <p>If "ON (ERROR)" is selected, a report is printed after the reception only if an error occurred.</p> <p>If "OFF" is selected, a report is not printed after each reception is finished. The report is not printed even if an error occurred.</p> <p>Choices: On, On (Error), Off</p> <p>Default: On (Error)</p> <p>Configuration Menu Equivalent:</p> <p style="text-align: center;">UTILITY - REPORTING - RX RESULT REPORT</p>

Item		Description
User Settings	Fax PTT Setting	Displays the country where this machine is installed. Configuration Menu Equivalent: UTILITY - ADMIN. MANAGEMENT - USER SETTINGS - PTT SETTING
	Date Format	Select the date display format for reports and lists. Choices: MM/DD/YY, DD/MM/YY, YY/MM/DD Default: MM/DD/YY Configuration Menu Equivalent: UTILITY - ADMIN. MANAGEMENT - USER SETTINGS - DATE FORMAT
	Preset Zoom	Select whether the zoom method is aligned on inch paper sizes or metric sizes when "Reduction RX" is set to "On". Choices: Inch, Metric Configuration Menu Equivalent: UTILITY - ADMIN. MANAGEMENT - USER SETTINGS - PRESET ZOOM
Auto Redial Settings	Number of Redials	Specify the number of redial attempts. Range: 1 to 10 Configuration Menu Equivalent: UTILITY - ADMIN. MANAGEMENT - AUTO REDIAL - NUMBER OF REDIAL
	Redial Interval	Specify the redial interval. Range: 1 to 99 Configuration Menu Equivalent: UTILITY - ADMIN. MANAGEMENT - AUTO REDIAL - INTERVAL
Apply button		Applies the configuration settings for this window.
Cancel button		Resets all configuration settings to previous values.

## Downloading/Uploading Destination List

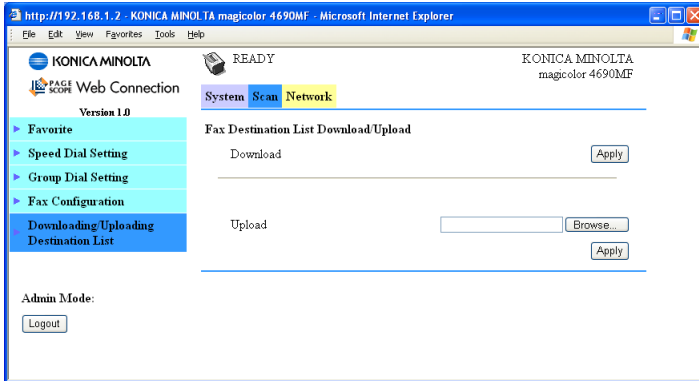

In the **Scan - Downloading/Uploading Destination List** window, the destination information can be downloaded or uploaded.

Item	Description
Download	Click the <b>Apply</b> button to save the registered destinations as a file on the computer being used.
Upload	Specify the location of the file containing the destinations, and then click the <b>Apply</b> button to write the destinations to the machine.



*When making changes to an exported CSV file, use a text editor. If the file is not saved using a text editor, an error will occur when the file is imported.*

## Network

The Network page allows you to configure the machine's network interface. For more information on these protocols, see chapter 6, "Network Printing."

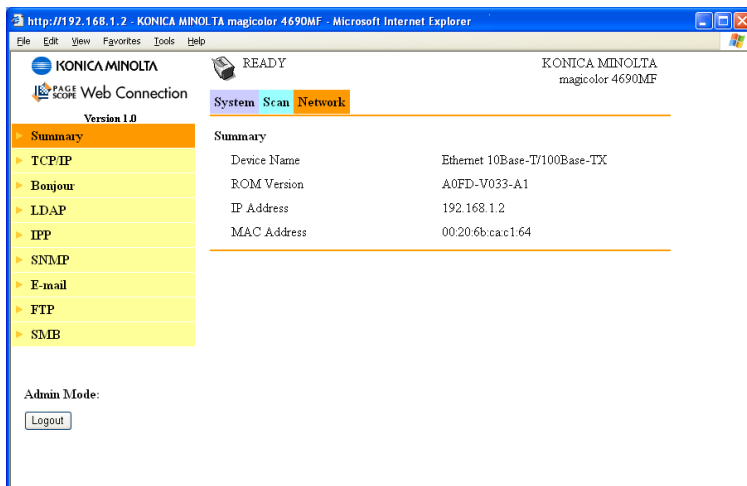

### Summary (shown above)

The **Network - Summary** window provides the following information:

Item	Description
Device Name	Displays information on the network interface.
ROM Version	Displays the version of the network firmware.
IP Address	Identifies the IP (Internet Protocol) address of the Ethernet interface.
MAC Address	Identifies the Media Access Control (MAC) address of the Ethernet interface.

# TCP/IP

## TCP/IP

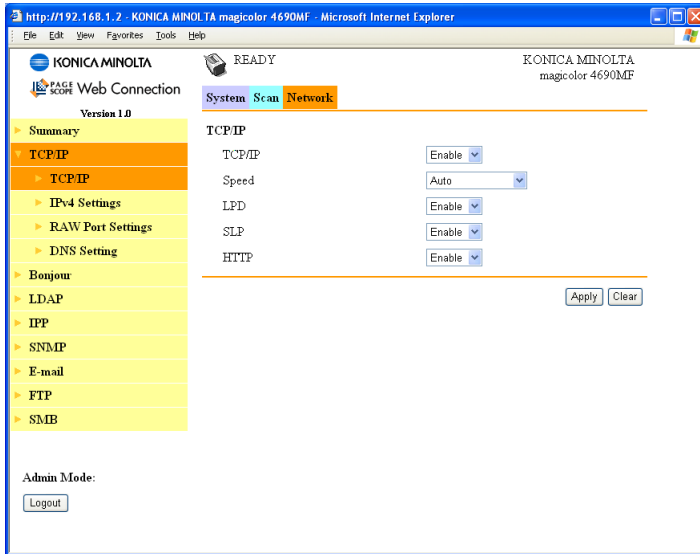

The **Network - TCP/IP - TCP/IP** window allows you to configure the following items. For more information on these TCP/IP settings, see chapter 6, “Network Printing.”

Item	Description
TCP/IP	Select whether or not to make a connection via TCP/IP. Choices: Enable, Disable Default: Enable Configuration Menu Equivalent: UTILITY - ADMIN. MANAGEMENT - NETWORK SETTING - TCP/IP
Speed	Select the transmission speed of the network. Choices: Auto, 10Base-T (Full), 10Base-T (Half), 100Base-TX (Full), 100Base-TX (Half) Default: Auto Configuration Menu Equivalent: UTILITY - ADMIN. MANAGEMENT - NETWORK SETTING - SPEED/DUPLEX
LPD	Select whether LPD is enabled or disabled. Choices: Enable, Disable Default: Enable



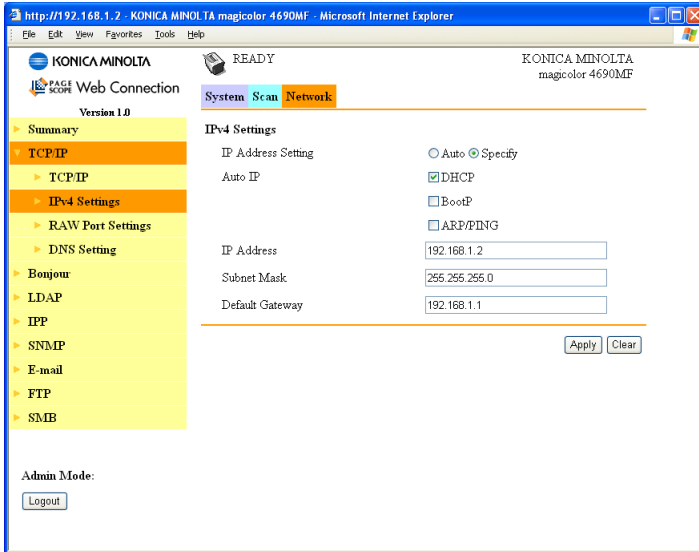

Item	Description
SLP	Select whether SLP is enabled or disabled. Choices: Enable, Disable Default: Enable Configuration Menu Equivalent: UTILITY - ADMIN. MANAGEMENT - NET- WORK SETTING - SLP
HTTP	Select whether HTTP is enabled or disabled. Choices: Enable, Disable Default: Enable Configuration Menu Equivalent: UTILITY - ADMIN. MANAGEMENT - NET- WORK SETTING - HTTP
Apply button	Applies the configuration settings in this window.
Clear button	Resets all configuration settings to previous values.

## IPv4 Settings



In the **Network - TCP/IP - IPv4 Settings** window, settings can be specified for the following parameters.

Item	Description
IP Address Setting	Select whether the IP address of the machine is assigned automatically or manually. Choices: Auto, Specify Default: Auto Configuration Menu Equivalent: UTILITY - ADMIN. MANAGEMENT - NETWORK SETTING - IP ADDR. SETTING
Auto IP	Select the method for automatically assigning the machine IP address. Choices: DHCP, BOOTP, ARP/PING Default: DHCP Configuration Menu Equivalent: UTILITY - ADMIN. MANAGEMENT - NETWORK SETTING - DHCP/BOOTP

Item	Description
IP Address	<p>Specifies the machine's IP address.            Range: 0 - 255 for each triplet            Default: 0.0.0.0</p> <p> <i>When IP Address Setting is set to "SPECIFY", the above values are not acceptable when click <b>Apply</b> button.</i></p> <p> <i>If the IP address is outside the range, the following message displays when you choose the Apply button: "Update Unsuccessful"            Go back to the previous screen, and then type an appropriate number.</i></p> <p>Configuration Menu Equivalent:            UTILITY- ADMIN. MANAGEMENT - NETWORK SETTING - IP ADDR. SETTING</p>
Subnet Mask	<p>Specifies the machine's subnet mask address.            Range: 0 - 255 for each triplet            Default: 255.255.255.0</p> <p> <i>If the subnet mask is outside the range, the following message displays when you choose the Apply button: "Update Unsuccessful"            Go back to the previous screen, and then type an appropriate number.</i></p> <p>Configuration Menu Equivalent:            UTILITY- ADMIN. MANAGEMENT - NETWORK SETTING - IP ADDR. SETTING</p>
Default Gateway	<p>If a router is used on the network, sets the router's address.            Range: 0 to 255 for each triplet            Default: 0.0.0.0</p> <p> <i>If the default gateway is outside the range, the following message displays when you choose the Apply button: "Update Unsuccessful"            Go back to the previous screen, and then type an appropriate number.</i></p> <p>Configuration Menu Equivalent:            UTILITY- ADMIN. MANAGEMENT - NETWORK SETTING - IP ADDR. SETTING</p>

<b>Item</b>	<b>Description</b>
Apply button	Applies the configuration settings in this window.
Clear button	Resets all configuration settings to previous values.

## RAW Port Settings

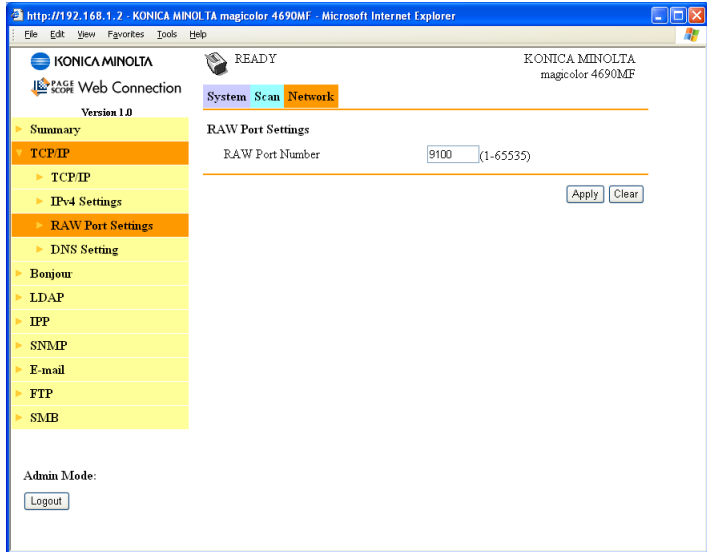

In the **Network - TCP/IP - RAW Port Settings** window, settings can be specified for the following parameters.

Item	Description
RAW Port Number	Specify the RAW port number (maximum of 5 digits). Range: 1 to 65535 Default: 9100   <i>The currently used port number and numbers 80, 161, 427, 443, 515, 631 and 4567 cannot be specified.</i>
Apply button	Applies the configuration settings in this window.
Clear button	Resets all configuration settings to previous values.

## DNS Settings

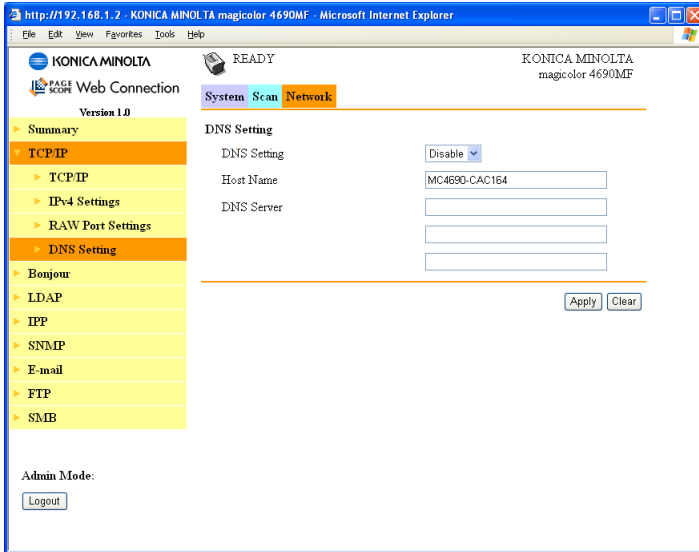

In the **Network - TCP/IP - DNS Setting** window, settings can be specified for the following parameters.

Item	Description
DNS Settings	Select whether DNS settings are enabled or disabled. Choices: Enable, Disable Default: Disable Configuration Menu Equivalent: UTILITY - ADMIN. MANAGEMENT - NETWORK SETTING - DNS CONFIG.
Host Name	Specify the host name of the machine. Range: Up to 63 characters Default: MC4690-xxxxxx  "xxxxxx" represents the last six digits of the MAC address.
DNS Server	Specify the address of the DNS server. Up to three addresses can be specified. Range: 0-255 for each triplet Default: 0.0.0.0 Configuration Menu Equivalent: UTILITY - ADMIN. MANAGEMENT - NETWORK SETTING - DNS CONFIG.

<b>Item</b>	<b>Description</b>
Apply button	Applies the configuration settings in this window.
Clear button	Resets all configuration settings to previous values.

## Bonjour

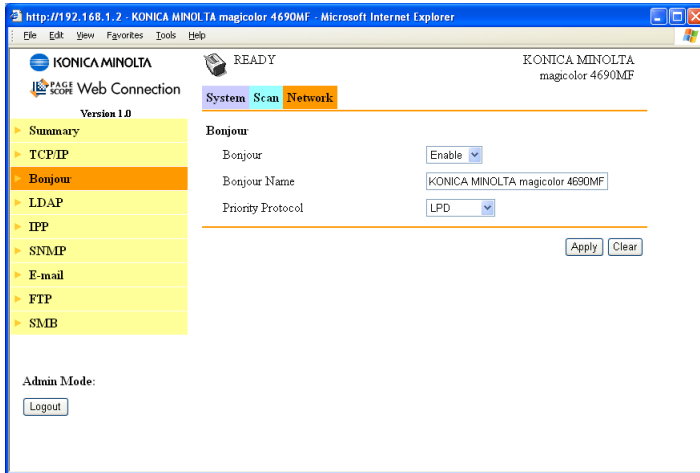

The **Network - Bonjour** window allows you to configure the following items.

Item	Description
Bonjour	Select whether to enable or disable the Bonjour function. Choices: Enable, Disable Default: Enable Configuration Menu Equivalent: UTILITY - ADMIN. MANAGEMENT - NETWORK SETTING - BONJOUR
Bonjour Name	Specify the Bonjour name for the printer. Range: Up to 63 characters Default: KONICA MINOLTA magicolor 4690MF (xx:xx:xx)  <i>“xx:xx:xx” refers to the last six digits of the MAC address (in hexadecimal).</i>
Priority Protocol	Select the protocol given priority. Choices: LPD, RAW Port, IPP Default: LPD
Apply button	Applies the configuration settings in this window.
Clear button	Resets all configuration settings to previous values.

# LDAP

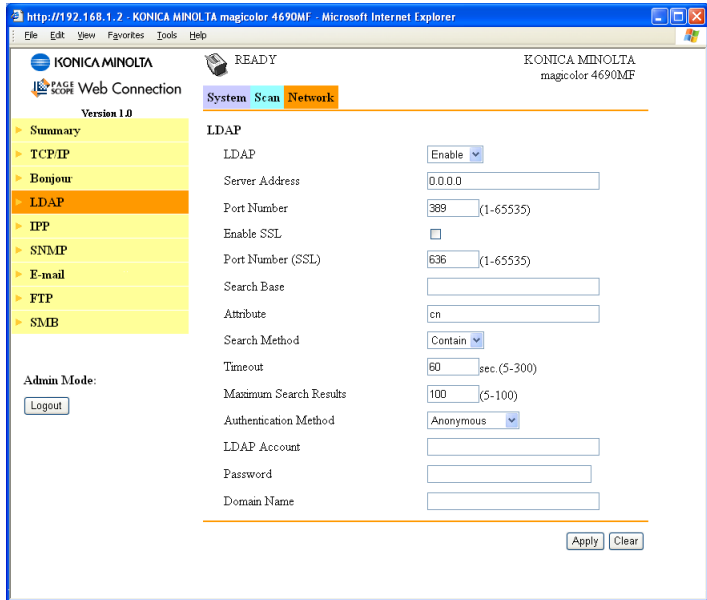

In the **Network - LDAP** window, settings can be specified for the following parameters.

Item	Description
LDAP	Select whether or not the LDAP server is used. Choices: Enable, Disable Default: Enable Configuration Menu Equivalent: UTILITY - ADMIN. MANAGEMENT - LDAP SETTING - DISABLE/ENABLE
Server Address	Specify the address of the LDAP server. Range: Up to 64 characters Default: 0.0.0.0 Configuration Menu Equivalent: UTILITY - ADMIN. MANAGEMENT - LDAP SETTING - LDAP SERVER ADDR.

Item	Description
Port Number	Specify the port number of the LDAP server. Range: 1 to 65535 Default: 389 Configuration Menu Equivalent: UTILITY - ADMIN. MANAGEMENT - LDAP SETTING - LDAP PORT NO.
Enable SSL	Select whether SSL is enabled or disabled. Choices: On, Off Default: Off Configuration Menu Equivalent: UTILITY - ADMIN. MANAGEMENT - LDAP SETTING - SSL SETTING
Port Number (SSL)	Specify the port number of the LDAP server when SSL is used. Range: 1 to 65535 Default: 636
Search Base	Specify the search starting point in a hierarchical structure arranged on the LDAP server. Range: Up to 64 characters Default: [Blank] Configuration Menu Equivalent: UTILITY - ADMIN. MANAGEMENT - LDAP SETTING - SEARCH BASE
Attribute	Specify the attribute that acquires. Range: Up to 32 characters Default: cn Configuration Menu Equivalent: UTILITY - ADMIN. MANAGEMENT - LDAP SETTING - ATTRIBUTE
Search Method	The specified characters can be searched for at the beginning, within or at the end. Choices: Begin, Contain, End Default: Contain Configuration Menu Equivalent: UTILITY - ADMIN. MANAGEMENT - LDAP SETTING - SEARCH METHOD

Item	Description
Timeout	<p>Specify the maximum wait time during a search.</p> <p>Range: 5 to 300</p> <p>Default: 60</p> <p>Configuration Menu Equivalent:</p> <p>UTILITY - ADMIN. MANAGEMENT - LDAP SETTING - LDAP TIMEOUT</p>
Maximum Search Results	<p>Specify the maximum number of destinations displayed after a search.</p> <p>Range: 5 to 100</p> <p>Default: 100</p> <p>Configuration Menu Equivalent:</p> <p>UTILITY - ADMIN. MANAGEMENT - LDAP SETTING - MAX. SEARCH RESULTS</p>
Authentication Method	<p>Select the authentication method used for logging on to the LDAP server.</p> <p>If “Anonymous” is selected, a user name and password are not necessary.</p> <p>If “Simple” is selected, a user name and password are necessary.</p> <p>If “Digest-MD5” is selected, use with a general LDAP server.</p> <p>If “GSS-SPNEGO” is selected, use with Active Directory in Windows.</p> <p>Choices: Anonymous, Simple, Digest-MD5, GSS-SPNEGO</p> <p>Default: Anonymous</p> <p>Configuration Menu Equivalent:</p> <p>UTILITY - ADMIN. MANAGEMENT - LDAP SETTING - AUTHENTICATION</p>
LDAP Account	<p>Specify the account used to connect to the LDAP server.</p> <p>Range: Up to 64 characters</p> <p>Default: [Blank]</p> <p>Configuration Menu Equivalent:</p> <p>UTILITY - ADMIN. MANAGEMENT - LDAP SETTING - LDAP ACCOUNT</p>
Password	<p>Specify the password used to connect to the LDAP server.</p> <p>Range: Up to 32 characters</p> <p>Default: [Blank]</p> <p>Configuration Menu Equivalent:</p> <p>UTILITY - ADMIN. MANAGEMENT - LDAP SETTING - LDAP PASSWORD</p>

Item	Description
Domain Name	Specify the necessary domain name used to connect to the LDAP server. Range: Up to 64 characters Default: [Blank] Configuration Menu Equivalent: UTILITY - ADMIN. MANAGEMENT - LDAP SETTING - DOMAIN NAME
Apply button	Applies the configuration settings in this window.
Cancel button	Resets all configuration settings to previous values.



*When an LDAP server is used, the correct search results may not be retrieved when the search is performed from a server using anonymous access.*

# IPP

http://192.168.1.2 - KONICA MINOLTA magicolor 4690MF - Microsoft Internet Explorer

KONICA MINOLTA READY KONICA MINOLTA magicolor 4690MF

Web Connection Version 1.0

System Scan Network

Summary  
TCP/IP  
Bonjour  
LDAP  
IPP  
SNMP  
E-mail  
FTP  
SMB

Admin Mode:  
Logout

IPP

Enable IPP

Printer Name: KONICA MINOLTA magicolor 4690MF

Printer Location: [Text Field]

Printer Information: [Dropdown Menu]

More Printer Information: [Text Field]

Printer Driver Installer: [Text Field]

Printer Make and Model: [Text Field]

More Printer Information - Manufacturer: [Text Field]

Operations Supported:

- Print Job
- Cancel Job
- Get Jobs
- Validate Job
- Get Job Attributes
- Get Printer Attributes

Document Format Supported:

- text/plain
- application/vnd.hp-pcl
- application/octet-stream



Document Format: application/octet-stream [Dropdown Menu]

Message from Operator: [Text Field]

job-k-octets-supported: 0-4,294,967 Kbyte

Apply Clear

The **Network - IPP** window allows you to configure the following items. For details on IPP, refer to chapter 6, “Network Printing.” In order to apply the settings, the printer must be turned off, then on again after the setting is specified.

Item	Description
Enable IPP	<p>Selects whether or not IPP is used.            Choices: On, Off            Default: On</p> <p> When “HTTP” is set to “Disable”, “Enable IPP” will automatically be set to “Off” (the “Enable IPP” check box will be cleared).</p> <p>Configuration Menu Equivalent:            UTILITY - ADMIN. MANAGEMENT -            NETWORK SETTING - IPP</p>
Printer Name	<p>Specifies the printer’s name.            Range: Up to 127 characters            Default: KONICA MINOLTA magicolor            4690MF (xx:xx:xx)</p> <p> “xx:xx:xx” refers to the last six digits of the MAC address (in hexadecimal).</p>
Printer Location	<p>Specifies the printer’s location.            Range: Up to 127 characters            Default: [Blank]</p>
Printer Information	<p>Specifies the printer information.            Range: Up to 127 characters            Default: [Blank]</p>
More Printer Information	<p>Specifies printer information that is more detailed than the information entered in the “Printer Information” box.            Range: Up to 127 characters            Default: [Blank]</p>
Printer Driver Installer	<p>Specifies the version information for the printer driver installer.            Range: Up to 127 characters            Default: [Blank]</p>
Printer Make and Model	<p>Specifies the printer model information.            Range: Up to 127 characters            Default: [Blank]</p>

Item		Description
More Printer Information Manufacturer		Specifies the printer manufacturer and other information. Range: Up to 127 characters Default: [Blank]
Operations Support	Print Job	If this check box is selected, Print Job is enabled. Default: Checked
	Cancel Job	If this check box is selected, Cancel Job is enabled. Default: Checked
	Get Jobs	If this check box is selected, Cancel Job is enabled. Default: Checked
	Validate Job	If this check box is selected, Validate Job is enabled. Default: Checked
	Get Job Attributes	If this check box is selected, Get Job Attribute is enabled. Default: Checked
	Get Printer Attributes	If this check box is selected, Get Printer Attribute is enabled. Default: Checked
Docu- ment Format Sup- ported	text/plain	Select whether or not this format is used. Default: Checked
	application/ vnd.hp-pcl	Select whether or not this format is used. Default: Checked
	application/ octet-stream	Select whether or not this format is used. Default: Checked
Document Format		From the drop-down list, select the format type. Choices: text/plain, application/vnd.hp-pcl, application/octet-stream Default: application/octet-stream
Message from Operator		Displays a message from the operator. Range: Up to 127 characters Default: [Blank]
job-k-octets-supported		0-4,294,967 Kbyte
Apply button		Applies the configuration settings for this window.
Clear button		Resets all configuration settings to previous values.

# SNMP

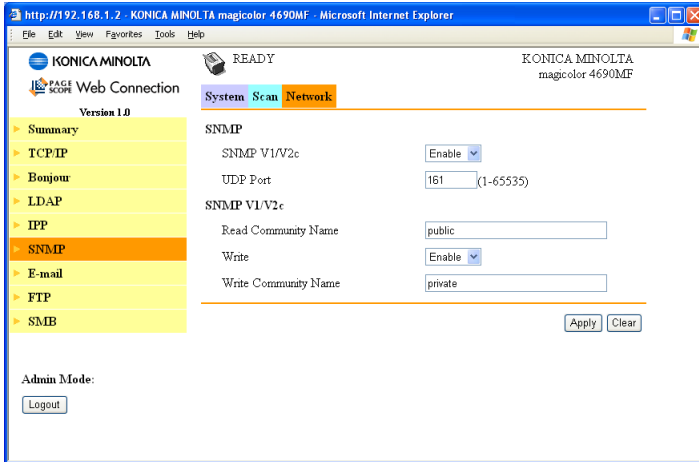

The **Network - SNMP** window allows you to configure the following items:

Item		Description
SNMP	SNMP V1/V2c	Select whether or not SNMP V1/V2c is used. Choices: Enable, Disable Default: Enable Configuration Menu Equivalent: UTILITY - ADMIN. MANAGEMENT - NETWORK SETTING - SNMP
	UDP Port	Specify the UDP port number. Range: 1 to 65535 Default: 161   <i>The currently used port number and numbers 80, 427, 443, 515, 631, 9100 and 4567 cannot be specified.</i>

<b>Item</b>		<b>Description</b>
SNMP V1/ V2c	Read Com- munity Name	Specify the read community name for SNMP. Range: Up to 15 characters Default: Public
	Write	Specify whether or not writing is permitted with SNMP. Choices: Enable, Disable Default: Enable
	Write Com- munity Name	Specify the write community name. Range: Up to 15 characters Default: private
Apply button		Applies the configuration settings for this window.
Clear button		Resets all configuration settings to previous values.

# E-mail

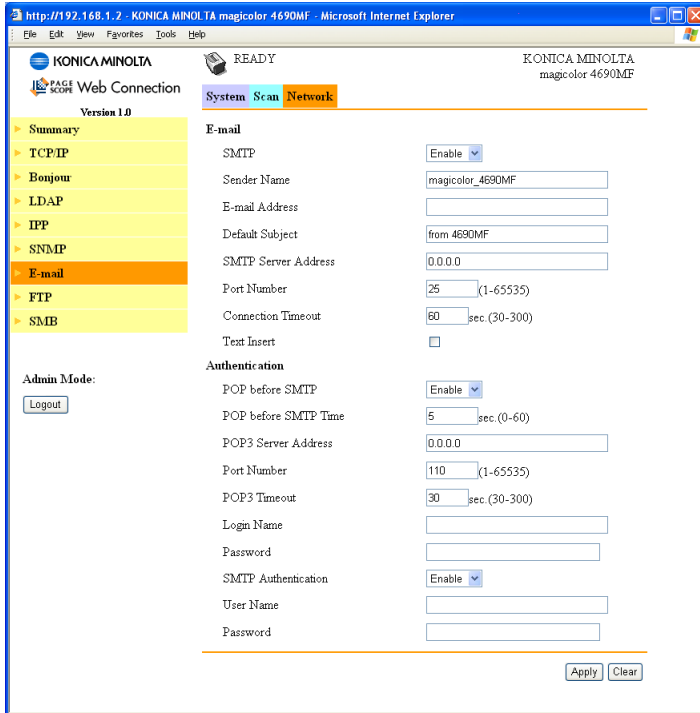

The **Network - E-mail** window allows you to configure the following items:

Item	Description
SMTP	If "Enable" is selected, sending E-mail is enabled. Choices: Enable, Disable Default: Enable Configuration Menu Equivalent: UTILITY - ADMIN. MANAGEMENT - E-MAIL SETTING - SMTP
Sender Name	Specify the name of the E-mail sender when using network scanning. Range: Up to 20 characters Default: magicolor_4690MF Configuration Menu Equivalent: UTILITY - ADMIN. MANAGEMENT - E-MAIL SETTING - SENDER NAME

Item	Description
E-mail Address	<p>Specify the E-mail address of the sender when using network scanning.</p> <p>Range: Up to 64 characters</p> <p>Default: [Blank]</p> <p>Configuration Menu Equivalent: UTILITY - ADMIN. MANAGEMENT - E-MAIL SETTING - E-MAIL ADDRESS</p>
Default Subject	<p>Specify the subject of the E-mail message when using network scanning.</p> <p>Range: Up to 20 characters</p> <p>Default: from 4690MF</p> <p>Configuration Menu Equivalent: UTILITY - ADMIN. MANAGEMENT - E-MAIL SETTING - DEFAULT SUBJECT</p>
SMTP Server Address	<p>Specify the IP address or host name for the SMTP server.</p> <p>Range: Up to 64 characters</p> <p>Default: 0.0.0.0</p> <p>Configuration Menu Equivalent: UTILITY - ADMIN. MANAGEMENT - E-MAIL SETTING - SMTP SERVER ADDR.</p> <p> <i>When specifying a setting for <b>SMTP Server Address</b>, also specify a setting for <b>E-mail Address</b>.</i></p>
Port Number	<p>Specify the port number communicating with the SMTP server.</p> <p>Range: 1-65535</p> <p>Default: 25</p> <p>Configuration Menu Equivalent: UTILITY - ADMIN. MANAGEMENT - E-MAIL SETTING - SMTP PORT NO.</p>
Connection Time-out	<p>Select the amount of time (in seconds) until the connection with the SMTP server times out.</p> <p>Range: 30-300</p> <p>Default: 60</p> <p>Configuration Menu Equivalent: UTILITY - ADMIN. MANAGEMENT - E-MAIL SETTING - SMTP TIMEOUT</p>

Item	Description
Text Insert	<p>Select whether or not the previously specified text is inserted into the body of the E-mail message when using network scanning.</p> <p>Choices: On, Off</p> <p>Default: Off</p> <p>Configuration Menu Equivalent: UTILITY - ADMIN. MANAGEMENT - E-MAIL SETTING - TEXT INSERT</p>
POP before SMTP	<p>If Enable is selected, POP before SMTP is enabled.</p> <p>Choices: Enable, Disable</p> <p>Default: Disable</p> <p>Configuration Menu Equivalent: UTILITY - ADMIN. MANAGEMENT - E-MAIL SETTING - POP BEFORE SMTP - DISABLE/ENABLE</p>
POP before SMTP Time	<p>Specify the time period to access the SMTP server after logging in to the POP server.</p> <p>Range: 0 - 60 (in seconds)</p> <p>Default: 5</p>
POP3 Server Address	<p>Type in the host name or IP address for the POP3 server used for authentication with POP before SMTP.</p> <p>Range: Up to 64 characters</p> <p>Default: 0.0.0.0</p> <p>Configuration Menu Equivalent: UTILITY - ADMIN. MANAGEMENT - E-MAIL SETTING - POP BEFORE SMTP - POP3 SERVER ADDR.</p>
Port Number	<p>Specify the port number used for communicating with the SMTP server.</p> <p>Range: 1 to 65535</p> <p>Default: 110</p> <p>Configuration Menu Equivalent: UTILITY - ADMIN. MANAGEMENT - E-MAIL SETTING - POP BEFORE SMTP - POP3 PORT NO.</p>

Item	Description
POP3 Timeout	<p>Select the amount of time (in seconds) until the connection with the POP3 server times out.</p> <p>Range: 30 to 300 Default: 30</p> <p>Configuration Menu Equivalent: UTILITY - ADMIN. MANAGEMENT - E-MAIL SETTING - POP BEFORE SMTP - POP3 TIMEOUT</p>
Login Name	<p>Type in the user name used for authentication with POP3 server.</p> <p>Range: Up to 63 characters Default: [Blank]</p> <p>Configuration Menu Equivalent: UTILITY - ADMIN. MANAGEMENT - E-MAIL SETTING - POP BEFORE SMTP - POP3 ACCOUNT</p>
Password	<p>Type in the password used for authentication with POP3 server.</p> <p>Range: Up to 15 characters Default: [Blank]</p> <p>Configuration Menu Equivalent: UTILITY - ADMIN. MANAGEMENT - E-MAIL SETTING - POP BEFORE SMTP - POP3 PASSWORD</p>
SMTP Authentication	<p>If "Enable" is selected, SMTP Authentication is enabled.</p> <p>Choices: Enable, Disable Default: Disable</p> <p>Configuration Menu Equivalent: UTILITY - ADMIN. MANAGEMENT - E-MAIL SETTING - SMTP AUTH. - DIS- ABLE/ENABLE</p>
User Name	<p>Type in the user name used for authentication with SMTP Authentication.</p> <p>Range: Up to 63 characters Default: [Blank]</p> <p>Configuration Menu Equivalent: UTILITY - ADMIN. MANAGEMENT - E-MAIL SETTING - SMTP AUTH. - SMTP USER NAME</p>

Item	Description
Password	Type in the password used for authentication with SMTP Authentication. Range: Up to 15 characters Default: [Blank] Configuration Menu Equivalent: UTILITY - ADMIN. MANAGEMENT - E-MAIL SETTING - SMTP AUTH. - SMTP PASSWORD
Apply button	Applies the configuration settings for this window.
Clear button	Resets all configuration settings for this window to their user defaults.



*Use alphanumeric characters (including some symbols) for the Sender Name and Default Subject. Using other characters will corrupt the characters for the E-mail destination. For details on characters that can be entered, refer to the Printer/Copier/Scanner User's Guide on the Documentation CD/DVD.*

# FTP

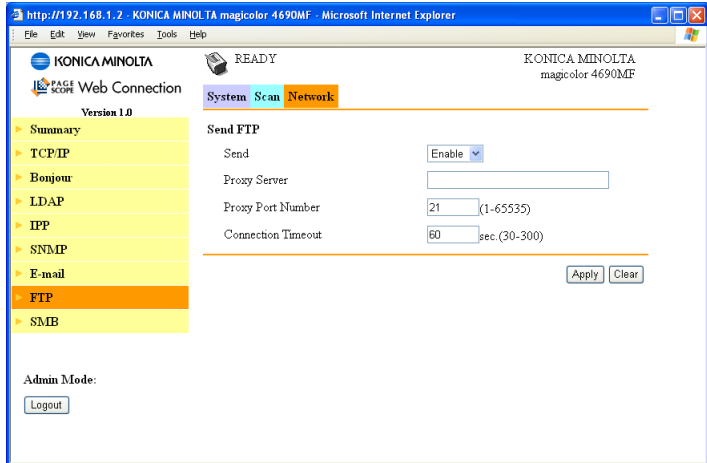

In the **Network - FTP** window, settings can be specified for the following parameters.

Item	Description
Send	If <b>Enable</b> is selected, FTP transmission is enabled. Choices: Enable, Disable Default: Enable Configuration Menu Equivalent: UTILITY - ADMIN. MANAGEMENT - NETWORK SETTING - FTP
Proxy Server	Specify the address when using via proxy server. Range: Up to 64 characters Default: [Blank]
Proxy Port Number	Specify the port number for the proxy server. Range: 1 to 65535 Default: 21
Connection Timeout	Select the amount of time (in seconds) until the connection with the FTP server times out. Range: 30 to 300 Default: 60
Apply button	Applies the configuration settings in this window.
Clear button	Resets all configuration settings to previous values.

# SMB

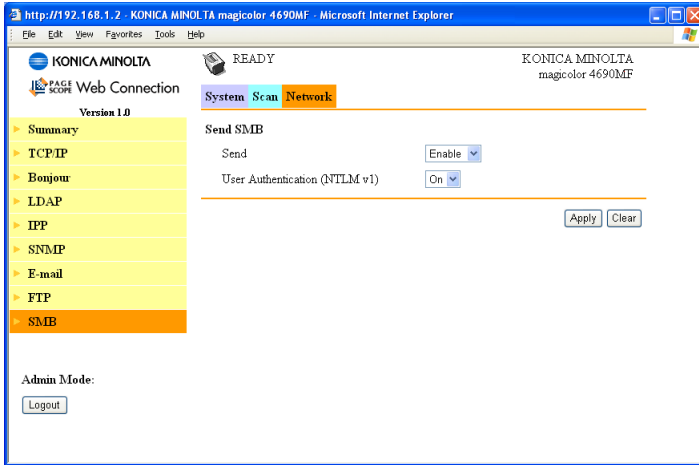

In the **Network - SMB** window, settings can be specified for the following parameters.

Item	Description
Send	If <b>Enable</b> is selected, SMB transmission is enabled. Choices: Enable, Disable Default: Enable Configuration Menu Equivalent: UTILITY - ADMIN. MANAGEMENT - NET- WORK SETTING - SMB
User Authentication (NTLM v1)	Select whether or not NTLM user authentication is performed. Choices: On, Off Default: On
Apply button	Applies the configuration settings in this window.
Clear button	Resets all configuration settings to previous values.

---

# Index

---

## A

**Administrator mode, PageScope Web**  
    **Connection** 180  
**ARP/PING** 157  
**Authentication, PageScope Web**  
    **Connection** 255

## B

**Bonjour** 15, 166  
**Bonjour, PageScope Web**  
    **Connection** 254  
**BOOTP** 157, 166

## C

**Configuration**  
    Network settings 150, 246  
    Printer, via PageScope Web  
        **Connection** 193  
**Configuration, PageScope Web**

**Connection** 246  
    Consumable 185, 198  
    Counter 206  
    Date/Time 210  
    DNS settings 252  
    Downloading/Uploading Destination  
        List 244  
    E-mail 264  
    E-mail destination 220  
    Fax Configuration 235  
    Fax destination 219  
    Group dial list 215  
    Group dial registration 233  
    Group Dial Setting 231  
    Initialize 205  
    Input Tray 182, 195  
    Interface Information 184, 197  
    IPP 259  
    IPv4 settings 248  
    LDAP 255  
    LDAP search 221

Machine Setting 202  
Online Assistance 188  
Online assistance 208  
Preference 199  
RAW Port settings 251  
Reset 204  
Reset Printer 204  
ROM Version 183, 196  
Save Setting 201  
SNMP 262  
Speed dial registration 218  
Speed dial registration (server) 222  
Speed Dial Setting 216  
Summary (Network) 245  
Summary (System) 193  
TCP/IP 246

## D

**DHCP** 163, 167  
**DNS** 167  
**DNS Settings, PageScope Web Connection** 252  
**Downloading/Uploading Destination List, PageScope Web Connection** 244

## E

**E-mail, PageScope Web Connection** 264  
**Ethernet interface** 163  
**Ethernet menu**  
  ARP/PING 157  
  Bonjour 158  
  BOOTP 157  
  DHCP 157  
  FTP 158  
  HTTP 157  
  IPP 158  
  SLP 159  
  SNMP 159  
  Speed/Duplex 159

## F

**Fax Configuration, PageScope Web**

**Connection** 235

**FTP** 158  
**FTP, PageScope Web Connection** 223

## G

**Gateway** 163  
  Manual setting 164  
**Group Dial Setting, PageScope Web Connection** 231

## H

**Host table** 177  
**HTTP** 167

## I

**Initialize, PageScope Web Connection** 205  
**Input tray, PageScope Web Connection** 195  
**Installing**  
  Ghostscript 3  
  LinkMagic 95  
  LSU 131  
  Printer driver 3, 7  
  Printer Utility 148  
  Scanner driver 78  
**IP address** 155, 163  
  Manual setting 164  
**IPP** 158, 167  
  Printing via 171  
**IPP, PageScope Web Connection** 158  
**IPv4 Settings, PageScope Web Connection** 248

## L

**LinkMagic** 94  
  Dialog box 124  
  Launcher buttons 122  
  Operating environment 94  
  Printing 116  
  Scan and Mail 111  
  Scan image 99  
  Scan to Clipboard 104

**LPD/LPR** 168

**LSU** 130

- Add a speed dial number 136
- Delete a speed dial number 138
- Edit a speed dial number 138
- Operating environment 130
- Programming a speed dial number 135

## M

**Mac OS X**

- Options 33
- Page setup settings 39
- Print Options 33
- Print settings 42
- Printer driver, installing 3
- Printer driver, uninstalling 37
- Printer Setup Utility 12
- System requirements 2
- Troubleshooting 89, 128, 146

## N

**Network connection** 162

- Address setting 164
- Ethernet interface 163
- Making connections 163
- Theory 162
- Using DHCP 163

**Network menu**

- Accessing 154
- IP address 155
- Overview 150
- Using options 154

**Network printing** 166

**Network, PageScope Web Connection** 197, 245

## O

**Online assistance, PageScope Web Connection** 208

## P

**Page setup settings** 39

- Custom paper size options 41

Page attributes options 40

**PageScope Web Connection** 176

- Administrator mode 180
- Consumables 198
- Counter 206
- Current status 180
- Downloading/Uploading Destination List 244
- E-mail 264
- Fax Configuration 235
- Group Dial Setting 231
- Initialize 205
- Navigation 179
- Printer configuration 193
- Requirements 176
- Reset Printer 204
- Save Setting 201
- Speed Dial Setting 216
- Summary (Network) 245
- Summary (System) 193
- User Mode 181
- Window 179

**POP Before SMTP** 168

**Preference, PageScope Web Connection** 199

**Printer name** 177

**Printer Setup Utility** 12

- Bonjour 15
- IP printing setting 18
- Network Connection 15
- USB connection 12

**Printer Utilities** 147

**Protocols, network**

- BOOTP 166
- DHCP 167
- DNS 167
- HTTP 167
- IPP 167
- LPD/LPR 168
- Port 9100 168
- SLP 168
- SNMP 169
- TCP/IP 170

## R

**RAW Port Settings, PageScope Web**

**Connection** 251  
**Refresh rate, PageScope Web Connection** 199  
**Reset Printer, PageScope Web Connection** 204  
**ROM Version, PageScope Web Connection** 183, 196

## S

**Save Setting, PageScope Web Connection** 201  
**Scan, PageScope Web Connection** 212  
    E-mail destination 220  
    Fax configuration 235  
    Fax destination 219  
    Group dial list 215  
    Group dial registration 233  
    LDAP search 221  
    Speed dial registration 218  
    Speed dial registration (server) 222  
**SLP** 168  
**SMB, PageScope Web Connection** 227  
**SMTP** 169  
**SMTPAuthentication** 169  
**SNMP** 169  
**Speed Dial Setting, PageScope Web Connection** 216  
**Subnet mask** 163  
    Manual setting 164  
**Summary (Network), PageScope Web Connection** 245  
**Summary (System), PageScope Web Connection** 193  
**System requirements**  
    Mac OS X 2  
**System, PageScope Web Connection** 193  
    Consumable 198  
    Counter 206  
    Date/Time 210  
    Initialize 205  
    Input Tray 195  
    Interface Information 197  
    Machine setting 202

Online assistance 208  
Preference 199  
Reset 204  
Save setting 201

## T

**TCP/IP** 170  
**TCP/IP, PageScope Web Connection** 246  
**Troubleshooting**  
    Mac OS X 89, 128, 146

## U

**Uninstalling**  
    LinkMagic 127  
    LSU 145  
    Printer driver 37

## W

**Web page, printer** 177  
    Browser 177  
    Printer name 177